

NEWALL

Kit Contents Lathe Bracket Kit 2 - Metric Part No: LBK02-M

This kit mounts one Spherosyn and one Microsyn reader head.



294-22520
Angle 2.5x2.5" (1)



ED-2768/2
Flat Plate Slotted (1)



ED-2768/3
Flat Bar (1)



294-35540
Micro Angle (1)



294-35550
Micro Plate (1)

600-65340 Single End Mount Kit (1)

- M5 x 16 Cap Head Screw (1)
- Single End Mount (1)
- M3 x 16 Cap Head Screw (1)
- Cable Clamp (6)

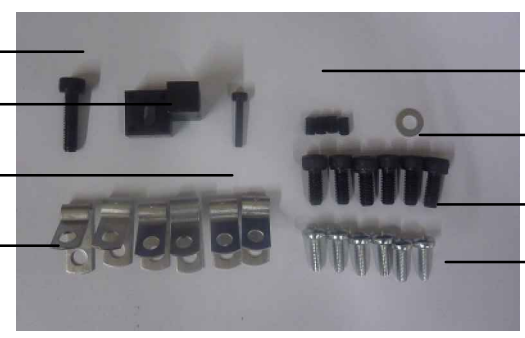

- M3 x 8 Grub Screw (4)
- M5 Washer (1)
- M4 x 10 Cap Head Screw (6)
- M4 x 10 Self Tapping Screw (6)

- Cable Ties (10)
- M6 x 20 Cap Head Screw (10)
- M6 x 25 Cap Head Screw (4)
- M5 x 30 Cap Head Screw (2)
- M4 x 10 Cap Head Screw (4)
- M4 x 12 Grub Screw (4)
- M4 Washer (4)



- M6 Nut (2)
- M5 x 20 Cap Head Screw (2)
- M4 x 30 Cap Head Screw (4)
- M4 x 20 Cap Head Screw (4)
- M5 Washer (4)
- M6 Washer (12)

note: some modification of brackets may be necessary during installation.

				TITLE. <i>KIT CONTENTS LBK02-M</i>			MATERIAL/FINISH. -----		SCALE N/A		UNLESS OTHERWISE TOLERANCES:- 0 DECIMAL PLACES ±0.5 STATED:- 1 DECIMAL PLACE ±0.2 DIMENSIONS ARE IN M.M. 2 DECIMAL PLACES ±0.1 ANGULAR ±1'		
1	25/02/15	9461	MISC CHANGES FOR INCH TO METRIC	CWH	DRAWN C. WHITMORE	08-01-14	 Leicester England		SHEET 1 OF 3 DRAWING NUMBER 023-81910		REV. ISS. 1		
REV. ISS.	DATE	C.N.No.	ALTERATION	CHECKED	APPROVED	THIS DRAWING IS THE PROPERTY OF NEWALL MEASUREMENT SYSTEMS LIMITED. THE INFORMATION THEREON MAY NOT BE COPIED OR USED WITHOUT WRITTEN PERMISSION							

NEWALL

Kit Contents Lathe Bracket Kit 2 - Metric Part No: LBK02-M

294-35540
Micro Angle (1)

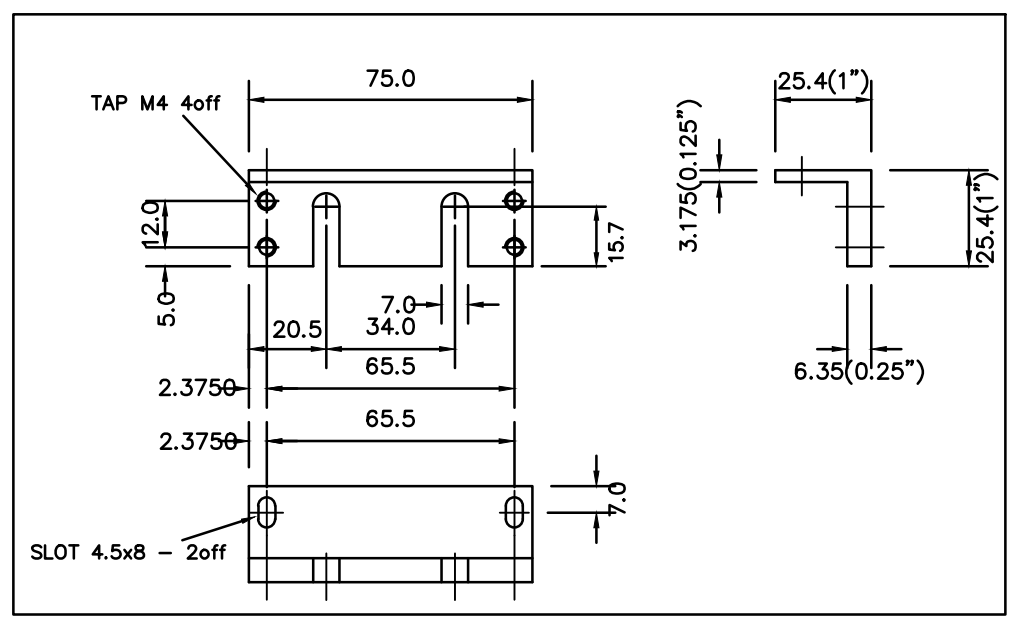

ED-2768/2
Flat Plate Slotted (1)

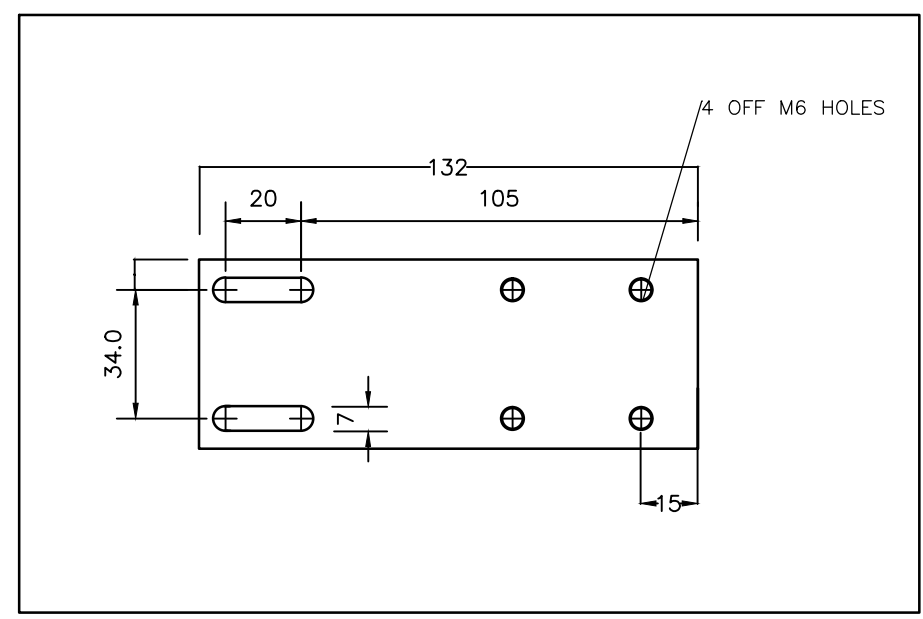

294-35550
Micro Plate (1)

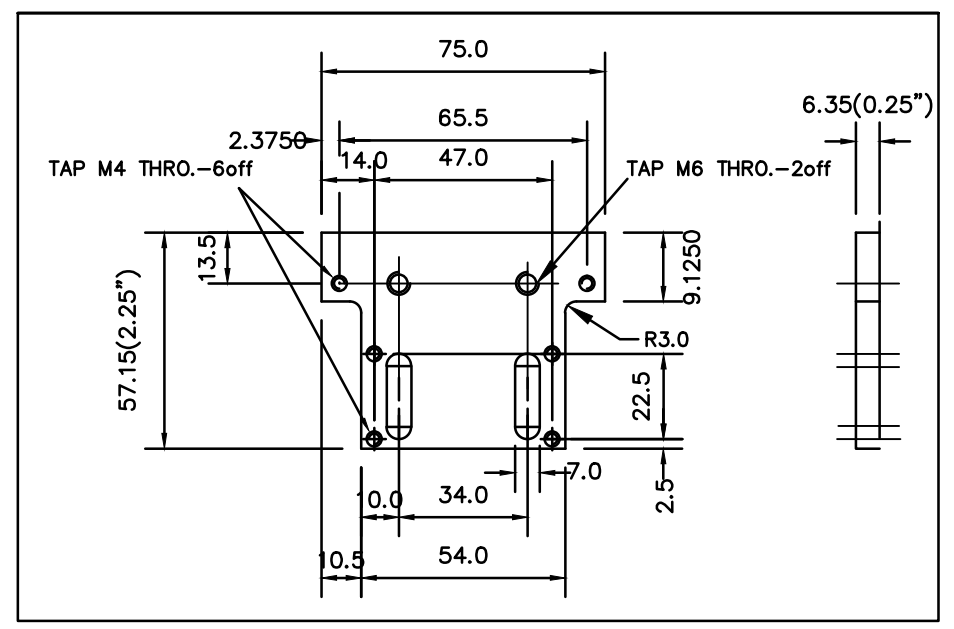

ED-2768/3
Flat Bar (1)

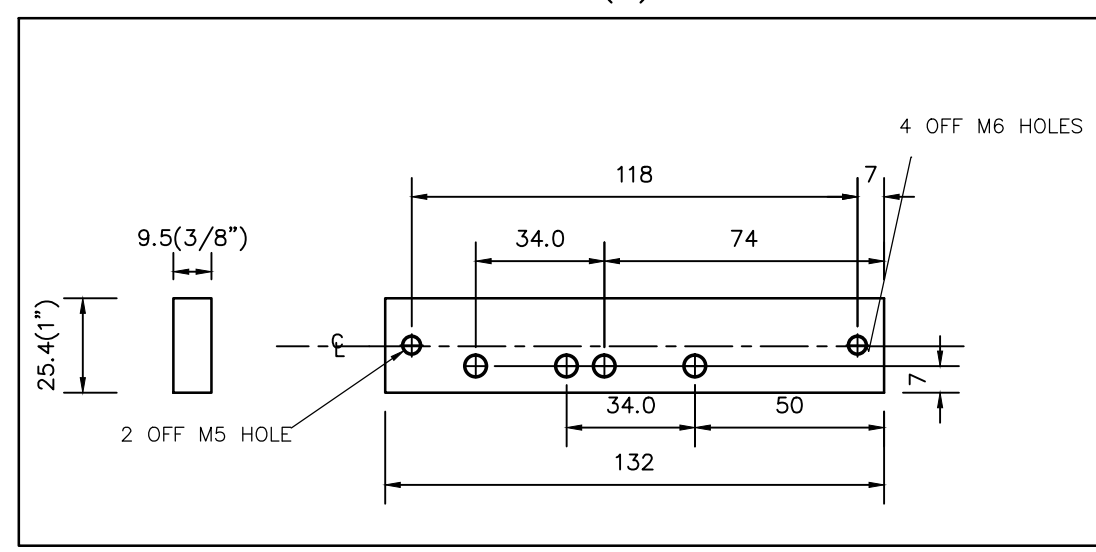

294-22520
Angle 2x2" (1)

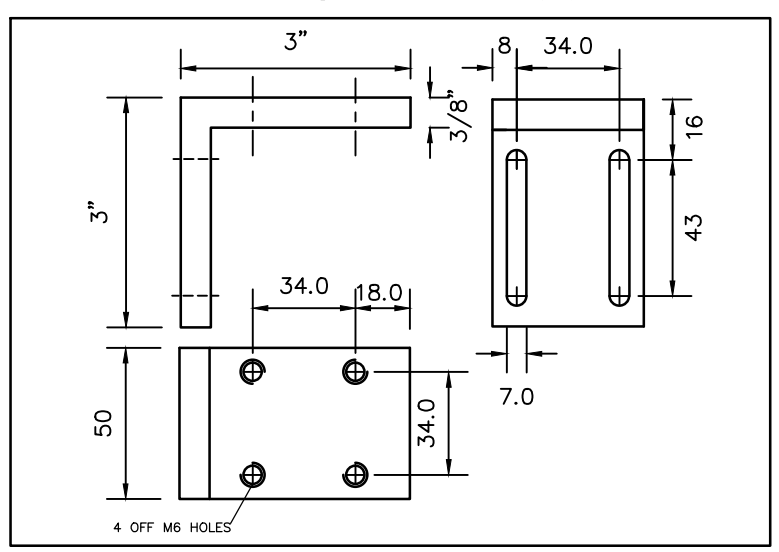

294-39910
Single End Mount (1)

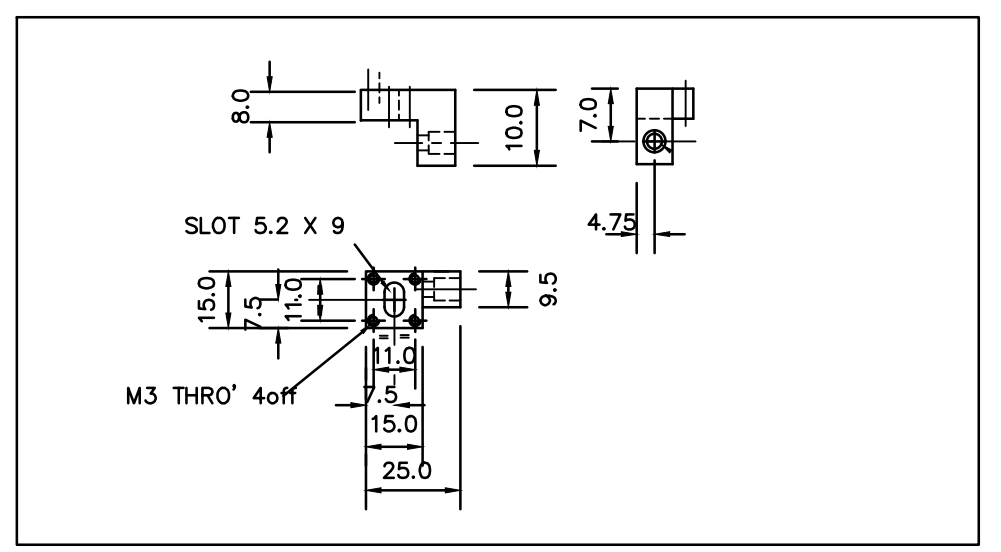

				TITLE. <u>KIT CONTENTS LBK02-M</u>		MATERIAL/FINISH. _____		SCALE N/A		UNLESS OTHERWISE STATED: -		TOLERANCES: - 0 DECIMAL PLACES ±0.5	
												1 DECIMAL PLACE ±0.2	
												2 DECIMAL PLACES ±0.1	
												ANGULAR ±1°	
1	25/02/15	9461	MISC CHANGES FOR INCH TO METRIC	CIH	DRAWN C. WHITMORE	08-01-14	 Leicester England		THIS DRAWING IS THE PROPERTY OF NEWALL MEASUREMENT SYSTEMS LIMITED. THE INFORMATION THEREON MAY NOT BE COPIED OR USED WITHOUT WRITTEN PERMISSION		SHEET 2 OF 3	DRAWING NUMBER 023-81910	REV. ISS. 1
REV. ISS.	DATE	C.N.No.	ALTERATION	CHECKED	APPROVED								

NEWALL

Kit Contents Lathe Bracket Kit 2 - Metric Part No: LBK02-M

Cross Slide (X-axis)

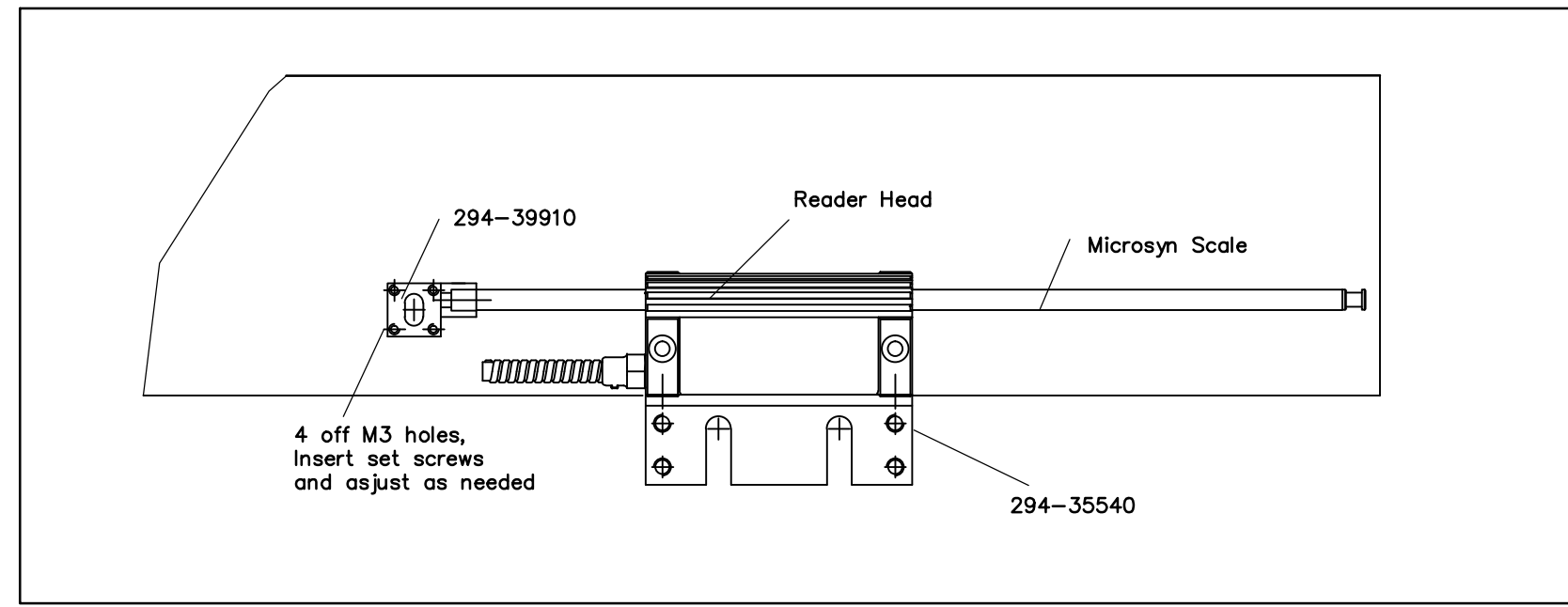

Longitudinal Axis (Z-axis)

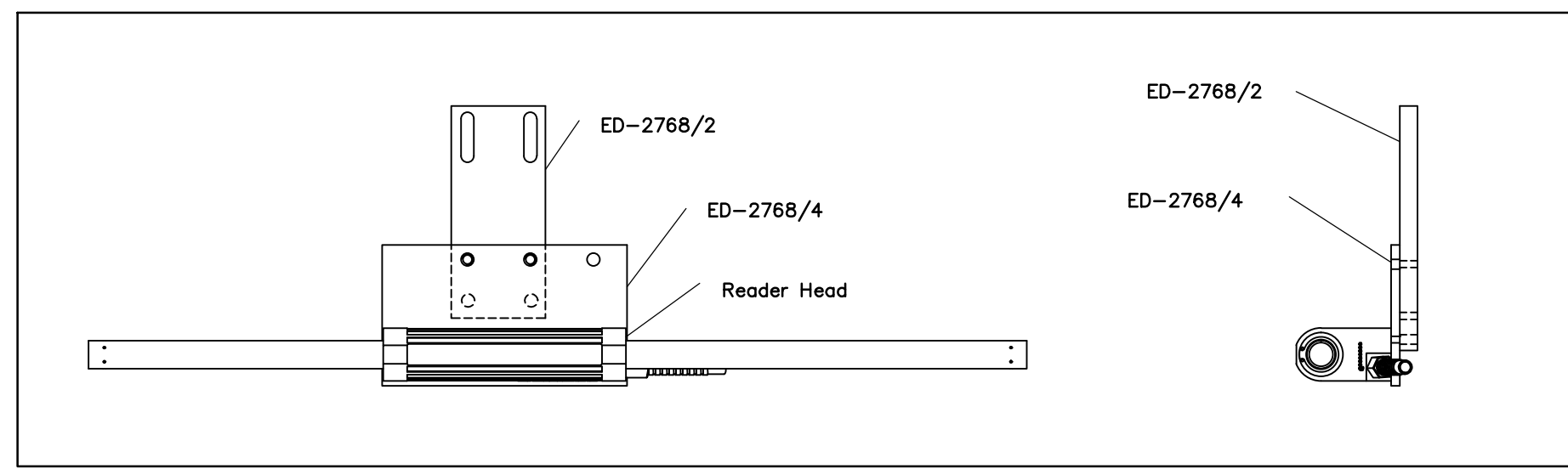

				TITLE. <i>KIT CONTENTS LBK02-M</i>			SCALE N/A	UNLESS OTHERWISE STATED: - TOLERANCES: - 0 DECIMAL PLACES ±0.5 1 DECIMAL PLACE ±0.2 2 DECIMAL PLACES ±0.1 ANGULAR	
1	25/02/15	9461	MSC CHANGES FOR INCH TO METRIC	CWH	DRAWN C.WHITMORE	08-01-14	SHEET 3 OF 3	DRAWING NUMBER 023-81910	REV. ISS. 1
REV.ISS.	DATE	C.N.No.	ALTERATION	CHECKED	APPROVED				

THIS DRAWING IS THE PROPERTY OF NEWALL MEASUREMENT SYSTEMS LIMITED. THE INFORMATION THEREON MAY NOT BE COPIED OR USED WITHOUT WRITTEN PERMISSION