

NEWALL

Newall Measurement Systems

Magnasyn™

D I G I T A L

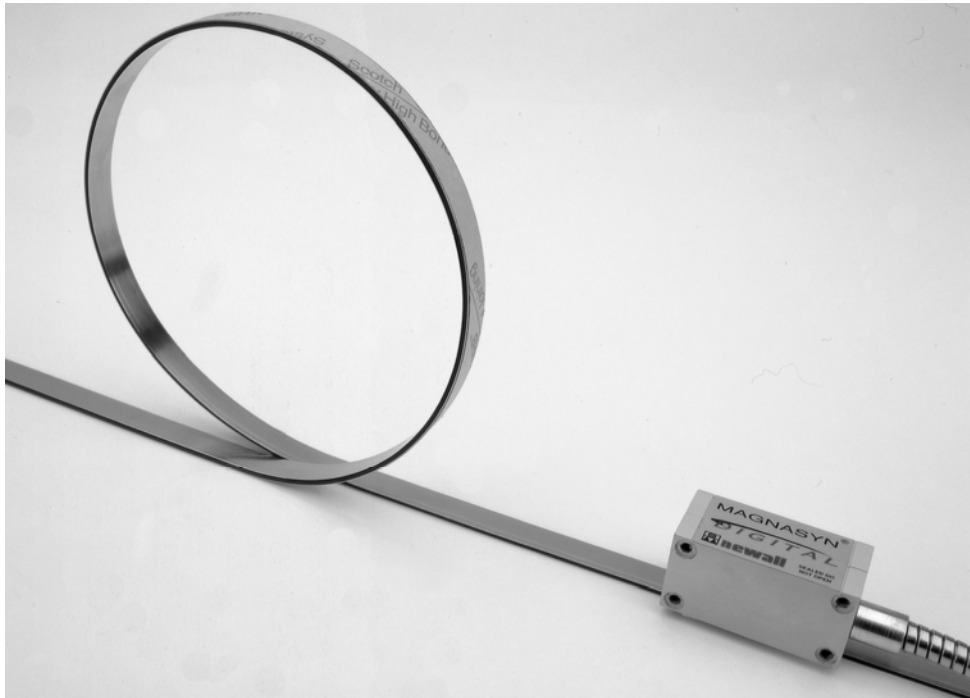

Linear Encoder

INSTALLATION MANUAL

CONTENTS

	Page
1.0 MECHANICAL PROPERTIES	1
1.1 <i>Tape Composition</i>	<i>1</i>
1.2 <i>Backing bar</i>	<i>1</i>
1.3 <i>Chemical Effects of Magnetic Tape and Adhesive</i>	<i>2</i>
1.4 <i>Surface Preparation</i>	<i>2</i>
1.5 <i>Adhesion Temperature</i>	<i>2</i>
2.0 INSTALLATION	3
2.1 <i>Head Alignment Tolerances</i>	<i>3</i>
2.2 <i>Head Installation</i>	<i>4</i>
2.3 <i>Tape Only Installations</i>	<i>5</i>
2.3.1 <i>Cover Strip</i>	<i>5</i>
2.3.2 <i>End Fixing Options</i>	<i>6</i>
2.3.3 <i>Rotary (non-linear) Installations</i>	<i>7</i>
2.4 <i>Backing Bar Installations</i>	<i>8</i>
2.4.1 <i>Standard Mounting Options</i>	<i>8</i>
2.4.2 <i>Calculation of Number of Backing Bar Brackets Required</i>	<i>8</i>
2.4.3 <i>Long Scales</i>	<i>9</i>

Technical Specification

Construction:	Aluminum Housing 6mm (1/4") Fully interlocked Stainless Steel conduit armoured cable. 9-way 'D-Type' connector or Flying lead	
Dimensions (reader head):		
Height	26mm (1.023")	
Width	24mm (0.787")	
Length	70mm (1.693")	(plus cable ferrule)
Weight	0.640Kg (1.410lbs)	(max. inc. 3.5m cable)
Operating Voltage:	5 VDC \pm 4% ripple < 50mV	
Supply Voltage Fluctuation:	Within operating voltage range	
Maximum Power Consumption:	<200mA	
Operating Temperature:	0 to 60°C (32 to 140°F)	
Storage Temperature:	-20 to 70°C (-4 to 158°F)	
Outputs:	Differential Quadrature with Synchronised Reference mark Via. RS422 compatible TTL line drivers	
Output frequency:	100kHz max (per channel) Proportional to speed	
Maximum Speed:	4m/s (157"/s)	
Maximum cable length:	22m (using Newall standard cables + extensions)	
Environmental Conditions:	IP67	
EMC Compliance:	BS EN 50081-2 Electromagnetic Compatibility Generic Emission Standard – Industrial Environment	
	BS EN 50082-2 Electromagnetic Compatibility Generic Immunity Standard – Industrial Environment	



Certificate No FM36096



NOTE: NEWALL MEASUREMENT SYSTEMS LIMITED RESERVES THE RIGHT TO CHANGE THE SPECIFICATION WITHOUT NOTICE

1.0 MECHANICAL PROPERTIES

1.1 Tape Composition

The magnetic tape comprises three components when installed as Tape only, Figure 1.1.

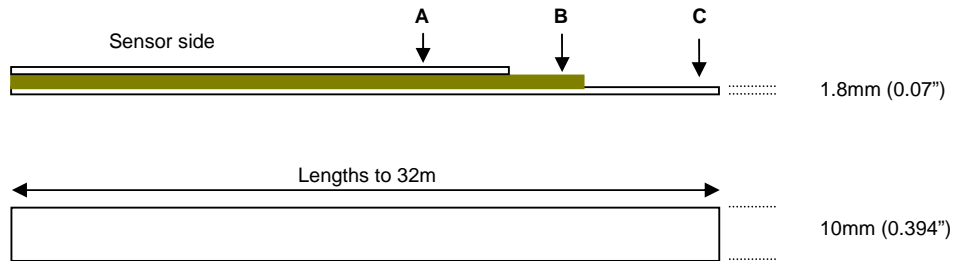

Figure 1.1 Laminated tape construction

- A** Non ferrous band used to mechanically protect the rubber cover 0.2mm (0.008") thick. For flexibility in transport this is supplied separately from the tape assembly and is mounted, on site, using supplied double-sided adhesive tape.
- B** The highly flexible rubber tape contains the magnetised poles used by the encoder to determine incremental movements.
- C** Ferrous flexible band pre-assembled to the magnetic tape. This medium holds the tape stable and provides the required magnetic path between poles. This is attached to the machine substrate or the backing bar carrier by means of double-sided adhesive tape.

1.2 Backing Bar

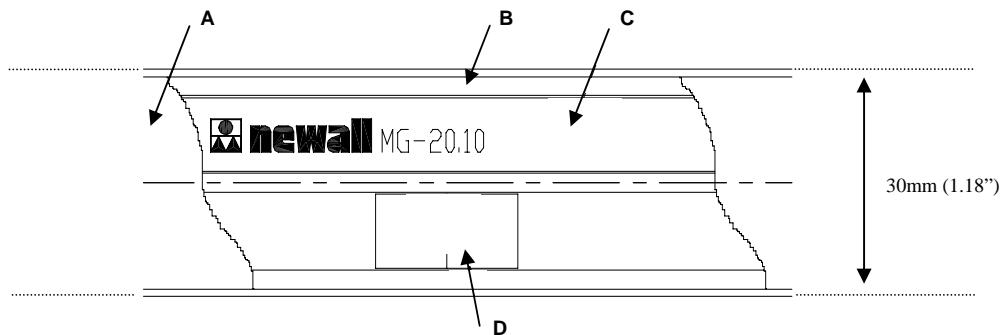

Figure 1.2 Backing bar assembly construction

- A** Non ferrous band 0.2mm (0.008") thick used to mechanically protect the rubber cover. For flexibility in transport this is supplied separately from the tape assembly and is mounted, on site, using supplied double-sided adhesive tape.
- B** Aluminum backing bar extrusion 6.35mm (0.25") thick.
- C** Magnatised rubber 'Encoder' tape. Mounted in to backing bar channel using double-sided adhesive tape.
- D** Optional reference marker tape containing a single magnetic pole. Located in parallel channel to the encoder tape. **Note: When Indexing always approach the index marker from the same direction.**

1.3 Chemical Effects of Magnetic Tape and Adhesive

Chemicals which have no effect:

Formic Acid	Glycerine 93°	Linseed Oil	Soyabean Oil
Cottonseed Oil	N-Hexan	Sour Milk	
Formaldehyde 40%	Isooktan	Mineral Oil	

Chemicals which have a detrimental effect:

Acetone	Benzene	Vinegar 30%	Oil Acid
Acetylene	Steam	Isopropalene	Sea Water
Ammonia (neat)	Acetic Acid 20%	Kerosene	Stearin Acid

Chemicals which are harmful:

Benzol	Saltoetre Solution	Turpentine	Toluol
Paint Thinners	Salt Solution 37% 93°C (200°F)	Carbon Tetrachloride	Tricoethylene
Nitro Benzol	Salt Acids 37% 93°C (200°F)	Tetrahydrofuran	Xylol

1.4 Surface Preparation

The laminated tape must be mounted, using the double-sided tape provided, to a clean, dry and flat surface. Isopropanol wipes are provided for this purpose. Ensure the surface has time to dry after cleaning. On materials such as copper, brass, etc, ensure that the surface is clear of any oxidant patina (corrosion).

1.5 Adhesion Temperature

For best adhesion results, installation should occur within a temperature range of +21 to +38°C (70 to 100°F). Once correctly applied the integrity of the bond is maintained even when exposed to temperatures below 0°C (32°F). The bond will reach maximum strength within 72 hours at 21°C (70°F).

Note: If the surface temperature of the substrate is 11°C (52°F) or less, the adhesive will be too hard and will result in poor bonding.

2.0 INSTALLATION

The Magnasyn *Digital* tape is to be mounted at least 500mm (20") away from sources of inductive and capacitive interference such as; circuit breakers, relays, motor contacts, PWM regulators, etc.

Locate the head cable so that it is run separately from power cables in order to reduce the likelihood of noise pickup. The cable consists of a 6mm (¼") conduit armour containing a PU coated multi-cable twisted pair core.

The Magnasyn *Digital* can be installed using one of the following methods;

- Tape only (Rotary applications must be of this form)
- With Backing bar

2.1 Head Alignment Tolerances

The maximum installation alignment tolerances can be seen in Figure 2.1.

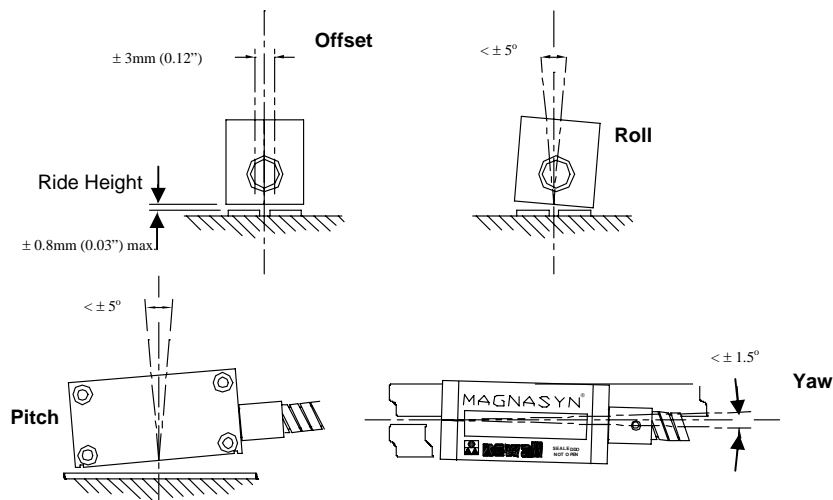

Figure 2.1. Reader head alignment tolerances

A plastic set-up shim is included with every reader head in order to ensure the nominally correct ride height of 0.4mm (0.01575") is configured. This set-up shim should only be used during installation and removed before operation.

Summary

Alignment	Min.	Max.
Offset	-3mm (0.12")	+3mm (0.12")
Ride Height	0	0.8mm (0.03")
Roll	-5°	+5°
Pitch	-5°	+5°
Yaw	-1.5°	+1.5°

2.2 Head Installation

The head bracket mounting kit contains two parts as shown in Figure 2.2. These can be configured to give the two mounting options shown in Figures 2.3a and 2.3b below. The location of the index and incremental pickup sensors can be seen in Figure 2.4.

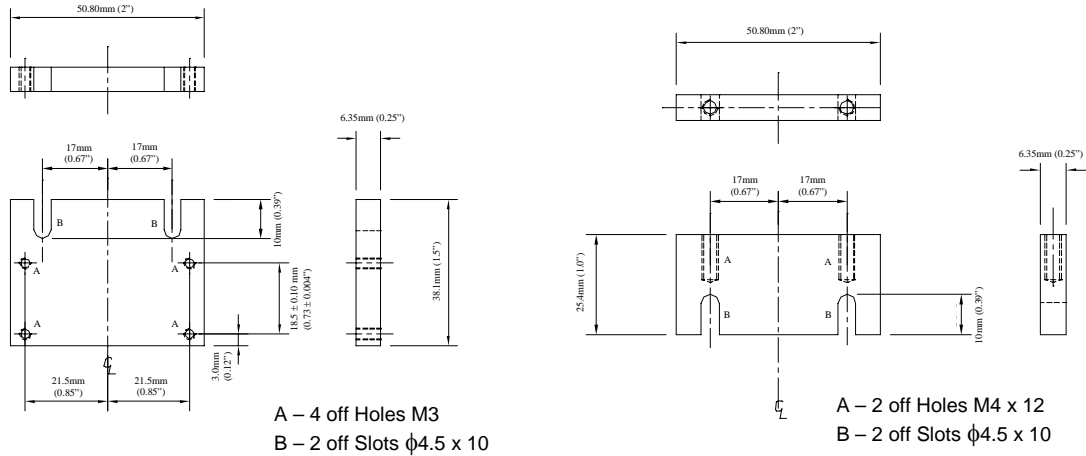

Figure 2.2. Reader head bracket parts

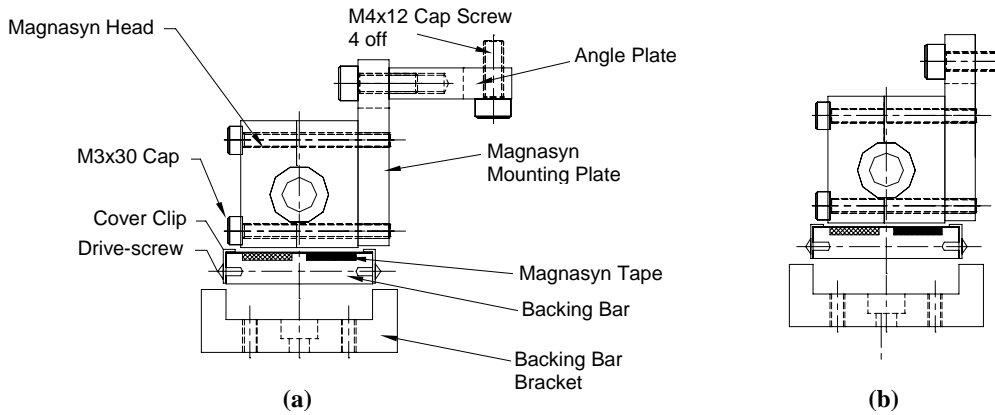

Figure 2.3. Reader head bracket configurations

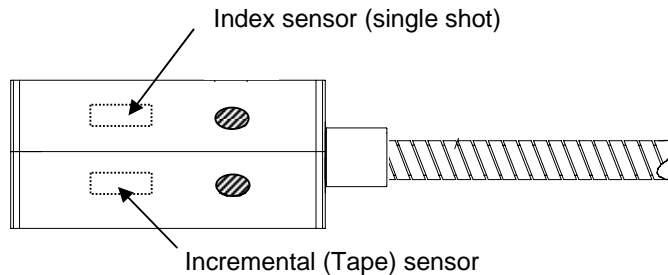

Figure 2.4. Location of sensors

2.3 Tape Only Installations

For both linear and rotary installations ensure surface is even and well prepared as described in Section 1.4. If the surface can not be cleaned or is irregular then a backing bar installation is required (Linear measuring only). See Section 2.5.

Measure the overall length of machine travel and ensure that the supplied length of tape is correct. If the tape is oversize then trim back preferably using a guillotine.

Mark the line of the tape on the machine bed using a pencil or marker pen.

Starting at one end of the installation, start to peel back the tape adhesive cover paper approximately 15cm (6"). Aligning the end of the tape to the guide marks applied to the machine bed press the Magnasyn tape down firmly.

Working along the length of travel continue to peel back the adhesive paper cover ensuring that the Magnasyn tape is being firmly pressed down in to the mounting surface. At all times, check that the Magnasyn tape is following the guidelines previously marked on the machine bed.

Once the tape has been located on the machine, using a dry, clean, lint-free cloth, firmly rub the tape along the line of travel. This will ensure that any air pockets are removed and that the adhesive is in firm contact with the machine mounting substrate.

2.3.1 Cover Strip

Once the tape has been applied to the mounting surface, a protective 0.2mm (0.00787") stainless steel cover strip is to be applied. This protects the soft magnetised rubber encoder tape from environmental conditions.

Apply the cover strip in the same manner as the Magnasyn tape. Starting from one end, peel back the adhesive cover paper and align the cover strip with the Magnasyn tape. Work along the length of travel peeling back the adhesive cover paper and firmly pressing down on the cover strip.

Once the cover strip has been located on the machine, using a dry, clean, lint-free cloth, firmly rub the tape along the line of travel. This will ensure that any air pockets are removed.

2.3.2 End Fixing Options

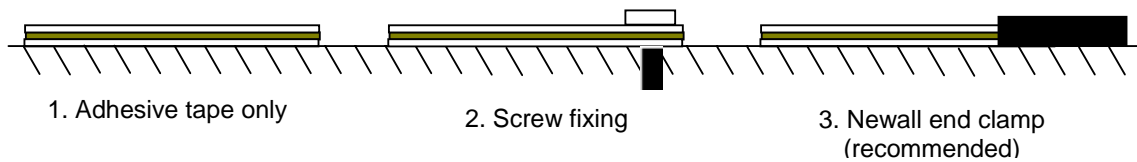

Figure 2.5 Optional end tape fixtures

- Option 1) Does **NOT** secure the tape ends to the mounting surface. However, it does provide a mechanism whereby the reader head can traverse past the end of the scale. This method can result in the scale peeling from the mounting surface if exposed to coolants or cutting fluids. If this fixing method is to be adopted, a two-part epoxy resin should be used to bond the scale to the mounting surface and the cover to the scale for the last 25mm (1").
- Option 2) Requires that the scale is mounted, the cover then centre-punched and the scale then drilled. The machine surface should then be tapped to accept a fixing bolt. Newall does not supply parts for this fixing method. This method offers a very secure fixing, however 25mm (1") of over travel should be allowed at each end to accommodate the fixing bolt.
- Option 3) This method consists of bonding the scale to the mounting surface and encapsulating it in a scale end cover and as such removes the need for any additional drilling. A two-part epoxy resin is employed for this purpose along with a moulded scale end cover. An optional fixing kit containing all the parts required for this method of mounting is available. 25mm (1") of over travel should be allowed at each end to accommodate the mounting of the end clamp.

2.4 Rotary (non-linear) Installations

ROTARY INSTALLATIONS CAN NOT USE BACKING BAR

Rotary installations are essentially "Tape only" installations as described in Section 2.3.

If the machine or device is likely to move through a complete revolution then a special form of tape end fixing is required as indicated in Figures 2.6 and 2.7. If this is not the case, then the installation can be treated as a simple tape installation as described in Section 2.3.

It should be noted that Magnasyn **CAN NOT** provide 360° of measurement. Where the tape is joined signal integrity **WILL** be lost and the counter will need to be re-datumed. Errors are **NOT** repeatable across a join.

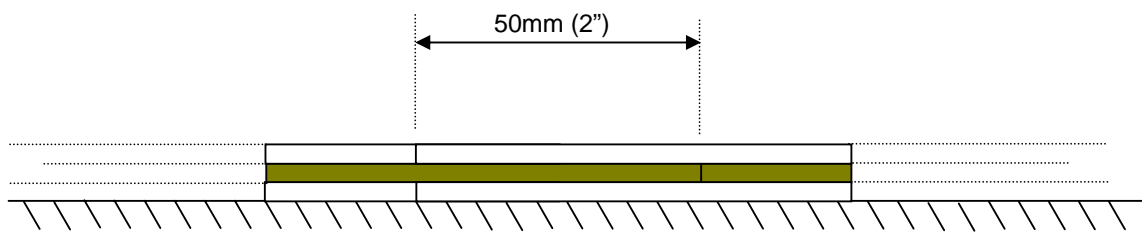

Figure 2.6 Layered tape end fixing

Forming an overlap at each layer in order to provide structural integrity forms the join. The layers are bonded to each other and the machine substrate using a two-part epoxy resin (available in the scale end clamp fixing kit). Pressure is to be applied to the join until the adhesive has set.

This is achieved by trimming the ends of the tape:

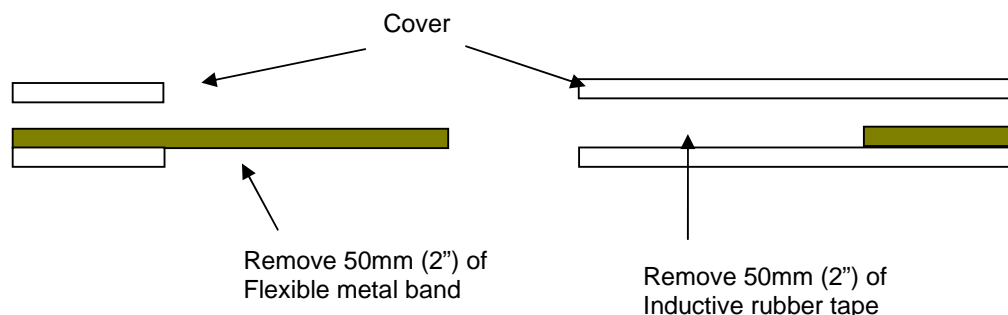

Figure 2.7 Formation of the overlap 'layered' join

The rubber tape should be cut cleanly across the width of the tape with a sharp knife or scalpel. The flexible metal band and cover strip is to be cut with a guillotine, tin snips or similar. All burrs are to be removed.

2.5 Backing Bar Installations

Backing bar is to be implemented where the mounting surface is uneven or not continuous.

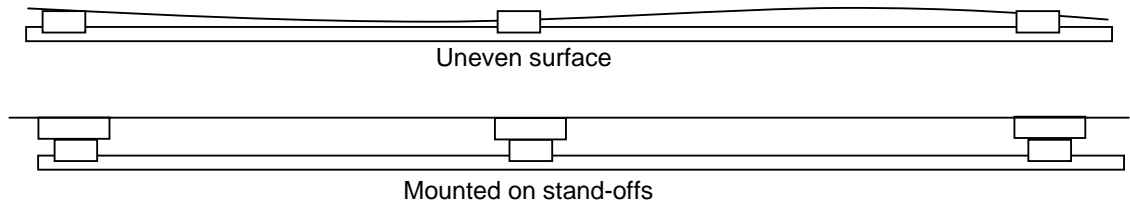

Figure 2.8. Typical backing bar installations

2.5.1 Standard Mounting Options

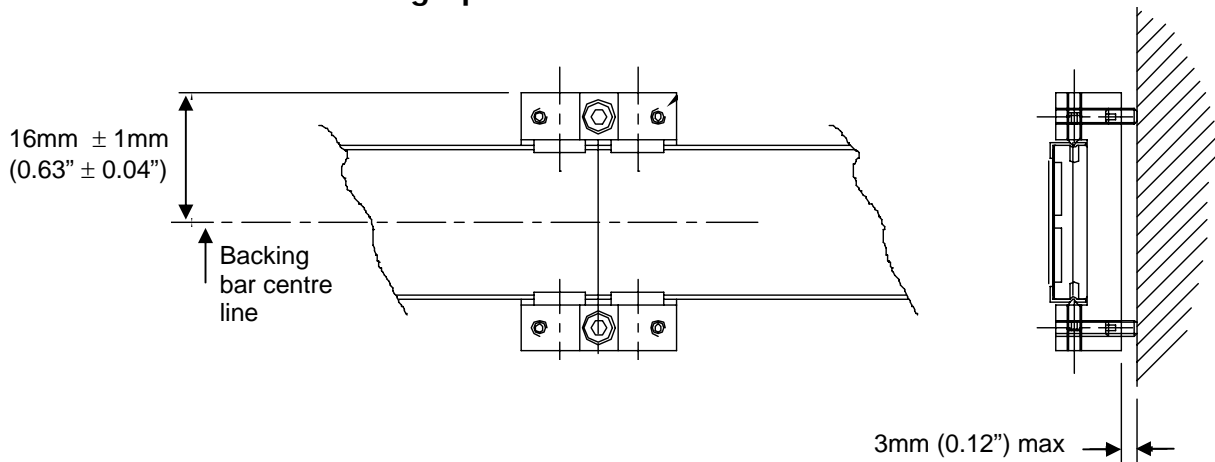

Figure 2.9. Backing bar mounting bracket installations

Backing assemblies are supplied as kits to be assembled directly on to the machine surface. The tape is applied after the mounting of the backing bar has been completed.

2.5.2 Calculation of Number of Backing Bar Brackets Required

It is recommended that backing bar mounting brackets are to be mounted evenly spaced 500mm (20") apart where possible.

No. Brackets = (Overall Length (m) x 2) + 1 i.e. for a 2m length 5 brackets are required.

**NO SINGLE UNSUPPORTED LENGTH OF BACKING BAR
SHOULD EXCEED 600MM (24")**

2.5.3 Long Scales

Where long travels are required, (up to a maximum of 32m, 1260feet), backing bar sections are to be joined together during installation to form a continuous length. Each join must occur at a point where a bracket can be mounted to ensure the sections are locked to each other and to the machine surface.

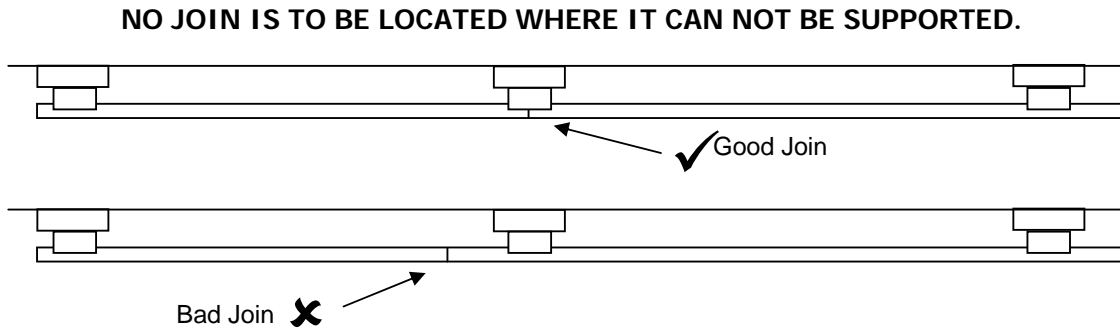

Figure 2.10. Backing bar joining positions

It is imperative when backing bar is to be used that machines are correctly surveyed in order to ensure correct installation.

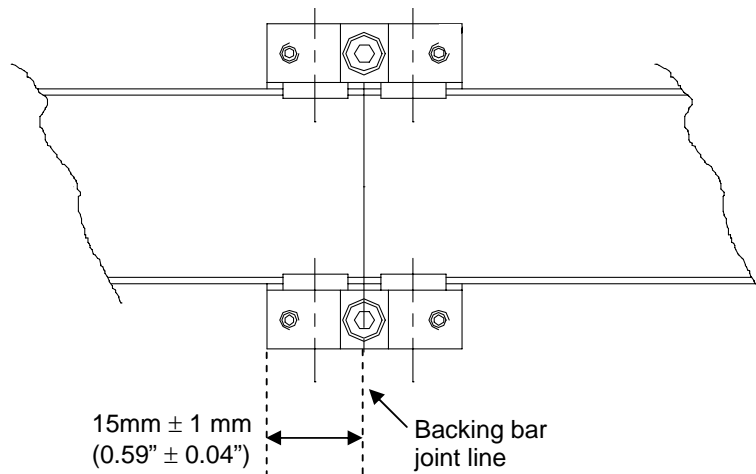

Figure 2.11. Location of the backing bar joint on a support bracket

Where required, due to mounting limitations, additional mounting brackets can be ordered.

NEWALL MEASUREMENT SYSTEMS LTD

Technology Gateway, Cornwall Road
South Wigston, Leicester, LE18 4XH
United Kingdom

E-mail: sales@newall.co.uk

NEWALL ELECTRONICS INC

1778 Dividend Drive . Columbus . Ohio . 43228. USA

Tel: (+1) 614 771 0213 . Fax: (+1) 614 771 0219

E-mail: sales@newall.com

Website: www.newall.com