

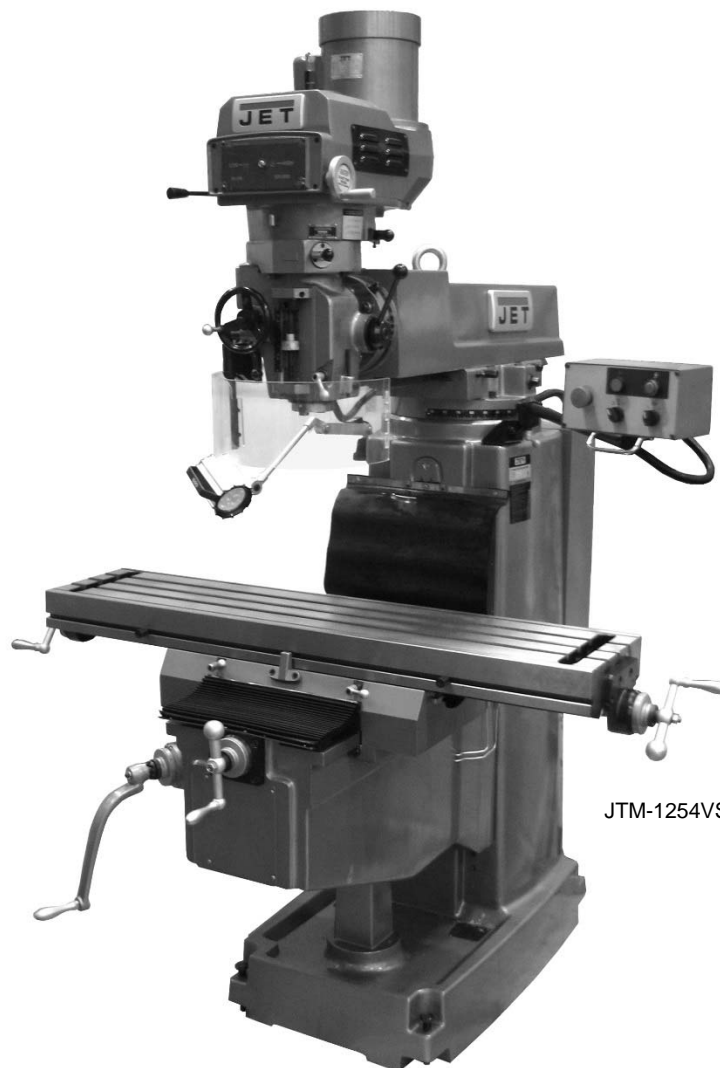

Operating Instructions and Parts Manual Variable Speed Turret Mill

Models JTM-1254VS and JTM-1254RVS



JTM-1254VS shown

JET
427 New Sanford Road
LaVergne, Tennessee 37086
Ph.: 800-274-6848
www.jettools.com

Part No. M-690025
Edition 2 11/2016
Copyright © 2016 JET



1.0 IMPORTANT SAFETY INSTRUCTIONS

To reduce the risk of injury:

1. Read and understand the entire owner's manual before attempting assembly or operation.
2. Read and understand the warnings posted on the machine and in this manual. Failure to comply with all of these warnings may cause serious injury. Replace warning labels if they become obscured or removed.
3. This turret mill is designed and intended for use by properly trained and experienced personnel only. If you are not familiar with the proper and safe operation of a turret mill do not use until proper training and knowledge have been obtained.
4. Do not use this turret mill for other than its intended use. If used for other purposes, JET disclaims any real or implied warranty and holds itself harmless from any injury that may result from that use.
5. Always wear approved safety glasses/face shields while using this turret mill. Everyday eyeglasses only have impact resistant lenses; they are not safety glasses.
6. Before operating this turret mill, remove tie, rings, watches and other jewelry, and roll sleeves up past the elbows. Do not wear loose clothing. Confine long hair. Non-slip footwear or anti-skid floor strips are recommended. Do not wear gloves.
7. Wear ear protectors (plugs or muffs) during extended periods of operation.
8. **CALIFORNIA PROPOSITION 65 WARNING:** This product contains chemicals known to the State of California to cause cancer, or birth defects or other reproductive harm.
9. This product, when used for welding, cutting, or working with metal, produces fumes, gases, or dusts which contain chemicals known to the State of California to cause birth defects and, in some cases, cancer. (California Health and Safety Code Section 25249.5 et seq.)
10. Do not operate this machine while tired or under the influence of drugs, alcohol or any medication.
11. Make certain the switch is in the OFF position before connecting the machine to the power supply.
12. Make certain the machine is properly grounded.
13. Make all machine adjustments or maintenance with the machine unplugged from the power source.
14. Remove adjusting keys and wrenches. Form a habit of checking to see that keys and adjusting wrenches are removed from the machine before turning it on.
15. Keep safety guards in place at all times when the machine is in use. If removed for maintenance purposes, use extreme caution and replace the guards immediately after completion of maintenance.
16. Check damaged parts. Before further use of the machine, a guard or other part that is damaged should be carefully checked to determine that it will operate properly and perform its intended function. Check for alignment of moving parts, binding of moving parts, breakage of parts, mounting and any other conditions that may affect its operation. A guard or other part that is damaged should be properly repaired or replaced.
17. Do not use power tools in damp/wet locations or other dangerous environments. Provide for adequate space surrounding work area and non-glare, overhead lighting.
18. Keep the floor around the machine clean and free of scrap material, oil and grease.
19. Keep visitors a safe distance from the work area. Keep children away. Workshop should be child proof with padlocks, master switches or by removing starter keys.
20. Give your work undivided attention. Looking around, carrying on a conversation and "horse-play" are careless acts that can result in serious injury.
21. Maintain a balanced stance at all times so that you do not fall against cutters or other moving parts. Do not overreach or use excessive force to perform any machine operation.
22. Use the right tool at the correct speed and feed rate. Do not force a tool or attachment to do a job for which it was not designed. The right tool will do the job better and more safely.
23. Use recommended accessories; improper accessories may be hazardous.
24. Maintain tools with care. Keep cutters sharp and clean for the best and safest performance. Follow instructions for lubricating and changing accessories.
25. Never brush away shavings or chips while machine is in operation. Turn off machine before cleaning. Use a brush or compressed air to remove chips — do not use your hands.

26. Avoid contact with coolant, especially guarding the eyes.
27. Do not stand on the machine. Serious injury could occur if the machine tips over.
28. Never leave the machine running unattended. Turn the power off and do not leave the machine until it comes to a complete stop.
29. Remove loose items and unnecessary work pieces from the area before starting the machine.
30. All work shall be secured using either clamps or a vise to the table. It is unsafe to use your hands to hold any workpiece being milled.
31. Mill head shall be securely locked in position before operating the machine.
32. Keep hands in sight. Do not put hands or fingers around, on, or below any rotating cutting tools. Leather safety gloves should be used when handling any sharp objects or cutting tools.
33. Always use the correct tooling. Tooling shall always be maintained and properly sharpened. All tooling must be run at the proper speeds and feeds as they apply to the job. Use only recommended accessories and follow those manufacturer's instructions pertaining to them. Tooling shall not be forced into any workpiece but fed according to the proper specifications. Failure to follow these instructions will not only ruin the tooling as well as the machine, but can cause serious injury.
34. Direction of feed – feed work into a blade or cutter against the direction of rotation of the blade or cutter only.
35. Installation work and electrical wiring must be done by a qualified electrician in accordance with all applicable codes and standards.

Familiarize yourself with the following safety notices used in this manual:

CAUTION This means that if precautions are not heeded, it may result in minor injury and/or possible machine damage.

WARNING This means that if precautions are not heeded, it may result in serious, or even fatal, injury.

SAVE THESE INSTRUCTIONS

2.0 About this manual

This manual is provided by JET, covering the safe operation and maintenance procedures for the JET Model JTM-1254VS and JTM-1254RVS Turret Mill. This manual contains instructions on installation, safety precautions, general operating procedures, maintenance instructions and parts breakdown. Your machine has been designed and constructed to provide consistent, long-term operation if used in accordance with the instructions as set forth in this document.

If there are questions or comments, please contact your local supplier or JET. JET can also be reached at our web site: www.jettools.com.

Retain this manual for future reference. If the machine transfers ownership, the manual should accompany it.

WARNING Read and understand the entire contents of this manual before attempting assembly or operation! Failure to comply may cause serious injury!

Register your product using the mail-in card provided, or register online:
<http://www.jettools.com/us/en/service-and-support/warranty/registration/>

3.0 Table of contents

Section	Page
1.0 IMPORTANT SAFETY INSTRUCTIONS	2
2.0 About this manual	3
3.0 Table of contents.....	4
4.0 Specifications.....	6
4.1 Machine dimensions – JTM-1254VS and JTM-1254RVS	7
4.2 Overview and terminology – JTM-1254VS and JTM-1254RVS	8
5.0 Set-up and assembly	9
5.1 Contents of shipping container.....	9
5.2 Preparing the mill for service.....	9
6.0 Electrical connections	10
6.1 General electrical cautions.....	10
6.2 Wire sizes.....	10
6.3 Voltage conversion.....	10
7.0 Lubrication.....	11
8.0 Operating instructions	11
8.1 Operating controls	11
8.2 Control panel	11
8.3 Control positions for milling and drilling operations	12
8.4 Spindle brake	13
8.5 High-low shift lever	13
8.6 Quill power feed lever.....	13
8.7 Feed rate lever	13
8.8 Feed trip cam lever.....	14
8.9 Spindle speed control.....	14
8.10 Feed direction control.....	14
8.11 Coarse feed handle	14
8.12 Quill lock handle	14
8.13 Depth scale and stop.....	14
8.14 Fine feed handwheel	15
8.15 Automatic feed operation	15
8.16 Draw bar operation – changing tooling.....	15
8.17 Clamping workpiece to table	16
9.0 Adjustments	16
9.1 Mill head – left/right adjustment.....	16
9.2 Positioning ram.....	17
9.3 Gib adjustment	17
9.4 Power feed trip lever mechanism	18
9.5 Table lead screw backlash adjustment	18
10.0 User-maintenance.....	20
10.1 Lubrication.....	20
10.2 Periodic maintenance requirements.....	21
11.0 Recommended speed for mill and drill operations.....	21
12.0 Replacement parts.....	21
12.1.1 JTM-1254VS Upper Head Assembly – Exploded View.....	22
12.1.2 JTM-1254VS Upper Head Assembly – Parts List	23
12.2.1 JTM-1254RVS (R8) Upper Head Assembly – Exploded View	26
12.2.2 JTM-1254RVS (R8) Upper Head Assembly – Parts List.....	27
12.3.1 JTM-1254VS Lower Head Assembly – Exploded View.....	30
12.3.2 JTM-1254VS Lower Head Assembly – Parts List	31
12.4.1 JTM-1254RVS (R8) Lower Head Assembly – Exploded View	34
12.4.2 JTM-1254RVS (R8) Lower Head Assembly – Parts List.....	35
12.5.1 JTM-1254VS Base Machine – Exploded View.....	38
12.5.2 JTM-1254VS Base Machine – Parts List.....	39
12.6.1 JTM-1254RVS (R8) Base Machine – Exploded View	41
12.6.2 JTM-1254RVS (R8) Base Machine – Parts List.....	42
12.7.1 JTM-1254VS/RVS Table Assembly – Exploded View.....	44
12.7.2 JTM-1254VS/RVS Table Assembly – Parts List	44

12.8.1	JTM-1254VS/RVS Control Box Assembly – Exploded View.....	45
12.8.2	JTM-1254VS/RVS Control Box Assembly – Parts List.....	45
12.9.1	JTM-1254VS/RVS Electrical Box – Exploded View	46
12.9.2	JTM-1254VS/RVS Electrical Box – Parts List	46
12.10.1	JTM-1254VS/RVS Coolant Pump (Optional) – Exploded View.....	47
12.11.1	JTM-1254VS/RVS Work Lamp – Exploded View.....	47
12.10.2	JTM-1254VS/RVS Coolant Pump (Optional) – Parts List	47
12.11.2	JTM-1254VS/RVS Work Lamp – Parts List.....	47
12.12.1	JTM-1254VS/RVS Spindle Guard Assembly – Exploded View.....	48
12.12.2	JTM-1254VS/RVS Spindle Guard Assembly – Parts List	48
12.13.1	JTM-1254VS/RVS Lubrication System – Exploded View.....	49
12.13.2	JTM-1254VS/RVS Lubrication System – Parts List	49
13.0	Electrical Connections – JTM-1254VS/RVS	50
14.0	Warranty and service	51

4.0 Specifications

Model Number.....JTM-1254VS JTM-1254RVS
 Stock Number690025 690020

Motor and Electricals:

Motor type TEFC TEFC
 Horsepower 5HP (3.75kW) 5HP (3.75kW)
 Phase 3 3
 Voltage 230V/460V, prewired 230V 230V/460V, prewired 230V
 Cycle 60Hz 60Hz
 Listed FLA (full load amps) 13/6.5A 13/6.5A
 Motor Speed (RPM) 1720 1720
 Power transfer Gears & belt Gears & belt
 Sound Emission ¹ (tested at 3.28 ft. from machine):
 Without load 72 dB 72 dB
 With load 80 dB 80 dB

Head and Spindle:

Spindle Taper NT40 R-8
 Diameter of Quill 4.13 in. (105mm) 3.375 in. (85.75mm)
 Number of Spindle Speeds Variable within specified range Variable within specified range
 Range of Spindle Speeds 80-500 / 500-3800 RPM 80-500 / 500-3800 RPM
 Downfeeds per Revolution of Spindle 0.003, 0.008, 0.0015 in. 0.003, 0.008, 0.0015 in.
 Spindle Travel 5 in. (127mm) 5 in. (127mm)
 Head Movement – Left and Right 90 deg L and R 90 deg L and R
 Head Movement – Fore and Aft n/a 45 deg F and A.
 Maximum Distance Spindle Nose to Table 23 in. (584mm) 23 in. (584mm)
 Maximum Distance Spindle Center to Column 26-1/2 in. (672mm) 26-1/2 in. (672mm)
 Minimum Distance Spindle Center to Column 7-1/2 in. (190mm) 7-1/2 in. (190mm)
 Collet Capacity 1/8 – 1 in 1/8 – 1 in
 Ram Travel, maximum 20.4 in. (518mm) 20.4 in. (518mm)

Table and Knee:

Table Size 12 x 54 in. (305 x 1372mm) 12 x 54 in. (305 x 1372mm)
 Longitudinal Table Travel, maximum 28-1/4 in. (718mm) 28-1/4 in. (718mm)
 Table Cross Travel, maximum 13-1/3 in. (390mm) 13-1/3 in. (390mm)
 Number of T-Slots 3 3
 T-Slot Size, width x depth 5/8 x 3/4 in. (15.9 x 19mm) 5/8 x 3/4 in. (15.9 x 19mm)
 T-Slot Centers 2-1/2 in. (64mm) 2-1/2 in. (64mm)
 Table Load, maximum 925 lbs. 925 lbs.
 Knee Travel, maximum 19-1/4 in. (489mm) 19-1/4 in. (489mm)

Misc. Dimensions:

Saddle width 25.6 in. (650mm) 25.6 in. (650mm)
 Column width 14-1/4 in. (362mm) 14-1/4 in. (362mm)
 Overall Dimensions (WxDxH) 104-1/4 x 79-7/8 x 92-1/8 in. (2648 x 2029 x 2340mm)

Weights:

Net Weight, approx. 3260 lbs. (1479 kg) 3260 lbs. (1479 kg)
 Shipping Weight, approx. 3969 lbs. (1800 kg) 3969 lbs. (1800 kg)

¹ The specified values are emission levels and are not necessarily to be seen as safe operating levels. As workplace conditions vary, this information is intended to allow the user to make a better estimation of the hazards and risks involved only.

n/a: not applicable

The specifications in this manual were current at time of publication, but because of our policy of continuous improvement, JET reserves the right to change specifications at any time and without prior notice, without incurring obligations.

4.1 Machine dimensions – JTM-1254VS and JTM-1254RVS

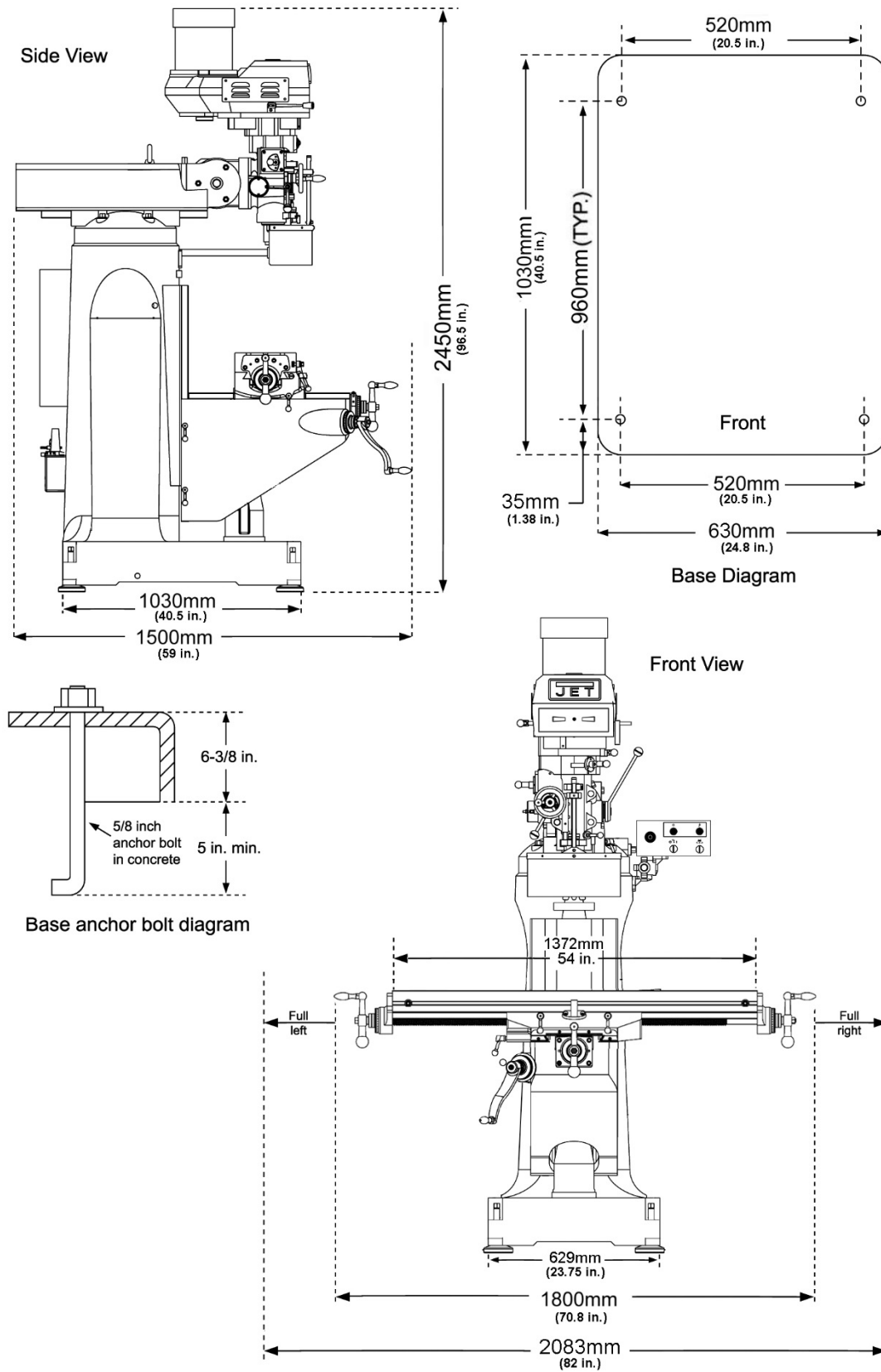

Figure 4-1: Installation Diagram

4.2 Overview and terminology – JTM-1254VS and JTM-1254RVS

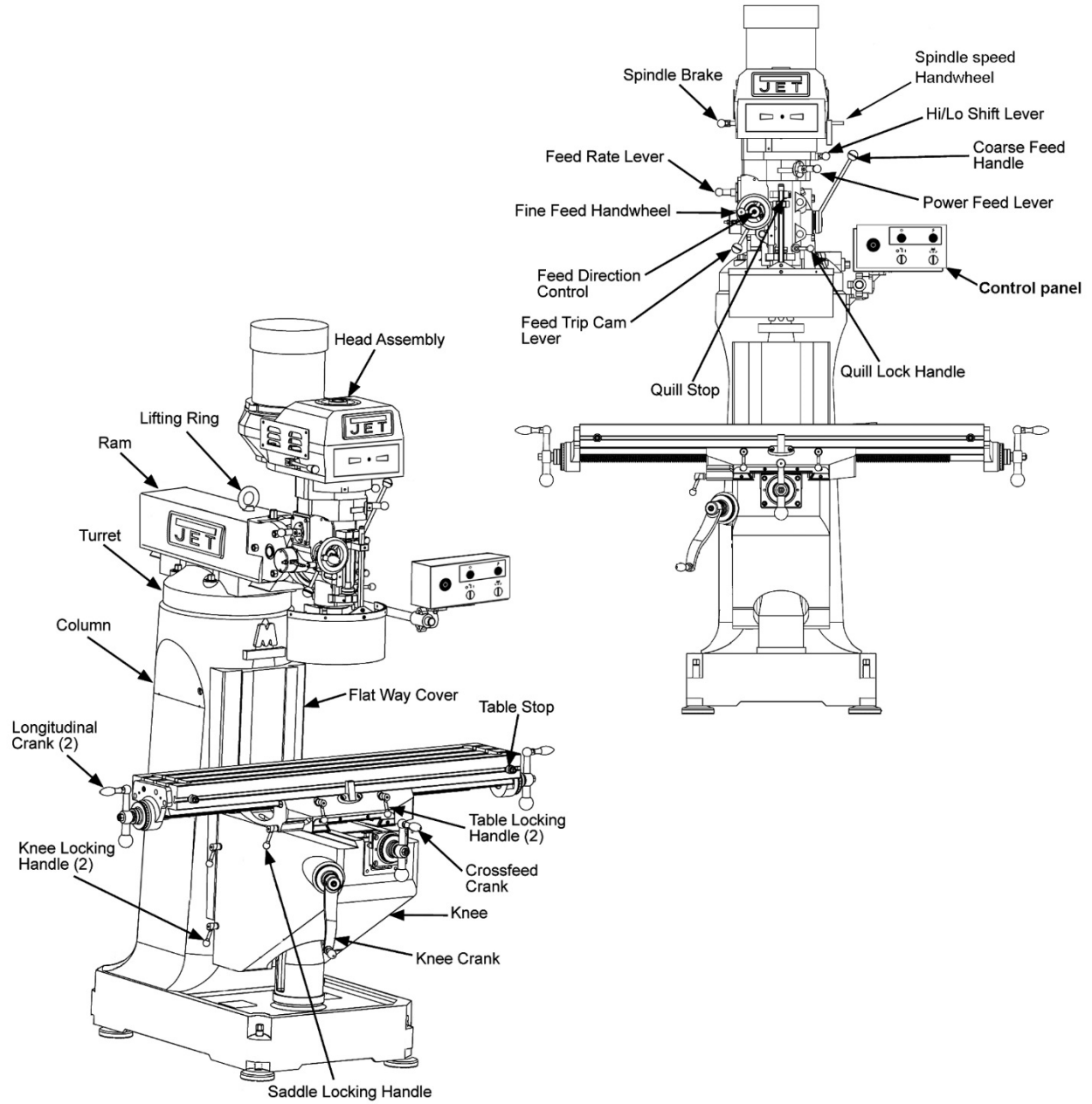

Figure 4-2: Overview

WARNING Read and understand the entire contents of this manual before attempting set-up or operation. Failure to comply may cause serious injury.

5.0 Set-up and assembly

Open shipping container and check for shipping damage. Report any damage immediately to your distributor and shipping agent. Do not discard any shipping material until the Turret Mill is assembled and running properly.

Compare the contents of your container with the following parts list to make sure all parts are intact. Missing parts, if any, should be reported to your distributor. Read the instruction manual thoroughly for assembly, maintenance and safety instructions.

If your mill is supplied with an optional Table Powerfeed and/or DRO, be sure to consult the separate instruction materials that accompany them.

5.1 Contents of shipping container

Note: Some parts may be pre-installed on the mill.



Figure 5-1: contents

- 1 Turret Mill (not shown)
- 1 Chip tray (not shown)
- 1 Flat Way Cover
- 1 Pleated Way Cover
- 1 Draw Bar
- 3 Table Adjustment Handles
- 1 Tool Box, containing:
 - 4 Leveling pads
 - 1 Hex Key Set (1.5-10mm) *

- 1 17/19mm Box Wrench *
- 1 Cross Point Screw Driver #2 *
- 1 Flat Blade Screw Driver #2 *
- 1 Oil Can *
- 1 Elevating Crank Handle
- 1 Handwheel
- 1 Coarse Feed Handle
- 1 Lifting ring
- 1 Electric box key
- 1 Operator's Manual
- 1 Warranty Card

* parts with an asterisk are also included in the tool box service kits, p/n JTM1254VS-TB and JTM1254RVS-TB.

5.2 Preparing the mill for service

1. Remove any crating which may be covering the machine on the pallet.
2. Remove accessory items from pallet or machine table. Compare items with *section 5.1*.
3. Check lifting ring on ram to be certain it is tight.
4. Check tightness of lock handles on ram (C and E, Figure 9-3) to be certain ram is locked tight.
5. Remove nuts and bolts which secure machine to pallet.
6. Center an overhead crane or other suitable overhead lifting device and sling arrangement over the lifting ring.

Note: This machine weighs over 3000 pounds – be certain lifting arrangement is new or in excellent condition and has a safety factor that will account for age, difficulties in lifting, etc. When lifting using the ring, the machine will tip forward. If you wish, you can minimize this tipping by rigging a support sling over front of machine. Be careful when doing this, to prevent sling from damaging any components on front of machine. Be sure to steady mill to prevent it from spinning.

7. Lift machine off pallet no higher than necessary to clear hold-down hardware, then pull pallet out of the way. Do NOT get hands or feet underneath machine when removing pallet!
8. Put machine base over hold-down system where machine will be spotted. Anchor bolts (not provided) of sufficient size and length must be fastened to the floor according to footprint of mill. See Figure 4-1.

Note: Figure 4-1 shows maximum dimensions of machines with table, ram, etc., fully extended in all possible directions. When spotting machine, be certain to leave room not only for the machine itself, but also for operator clearance and clearance for workers servicing the machine, and any unusual sizes of workpieces that might extend off the machine's table.

- When machine is over its anchors, level machine using the bolts at the corners of base. Also use shims if needed. The machinist's level used for leveling should be placed on the table. The table is the reference surface for both side-to-side and fore-and-aft leveling. Be certain you get it level in BOTH directions.

CAUTION Mill must be supported equally under all four corners. Failure to comply may cause column to twist and put a bind in the table ways.

- When machine is level, secure base to anchor system.

IMPORTANT: Before attempting to raise mill head, refer to *section 9.1* for procedures to safely raise and set up the mill head.

- Loosen the four hex head nuts (see A, Figure 9-1) about 1/4 turn each (counterclockwise), just enough to allow rotation of head.
- While assisting the worm mechanism by putting upward pressure on the motor by hand, use the supplied wrench to turn worm nut and raise head to upright position.
- Tighten the head bolts slightly — not torqued — just snug.
- Using mineral spirits or other cleaning solvent, clean all of the rust proofing from where it may have been applied. This is important; moving the table or any other components before removing the rust proofing will only put rust proofing where you don't want it.

Some of the following steps may have already been performed on the machine. If so, ignore the instructions related to those particular steps. Otherwise, perform them in the order listed. Refer to Figure 4-2 to help locate items.

- Install table longitudinal and cross-feed cranks on their respective shafts using the nuts on the shafts to secure the cranks.
- Remove any rust proofing from drawbar and its spacer, and put drawbar with spacer installed into spindle center through top of machine.
- Slide fine feed handwheel onto handwheel hub and push until its roll pin engages hole in hub and handwheel is flush with hub surface.
- Install coarse feed handle on feed shaft and tap it lightly until its roll pin engages hole in hub and it is flush against hub surface.
- Unwrap and clean knee crank and install it on its shaft.
- Install rubber way covers at front and behind table.

6.0 Electrical connections

WARNING All electrical connections must be made by a qualified electrician! Failure to comply may cause serious injury!

6.1 General electrical cautions

This machine must be grounded in accordance with the National Electrical Code and local codes and ordinances. This work should be done by a qualified electrician. The machine must be grounded to protect the user from electrical shock.

NOTE: The machine's electrical box has a switch interface. Door will not open if main switch is ON.

6.2 Wire sizes

CAUTION For circuits which are far away from the electrical service box, the wire size must be increased in order to deliver ample voltage to the motor.

To minimize power losses and to prevent motor overheating and burnout, the use of wire sizes for branch circuits or electrical extension cords according to the following table is recommended:

Conductor Length	AWG Number
	230/460 Volt Lines
0 – 50 Ft.	No. 14
50 – 100 Ft.	No. 14
Over 100 Ft.	No. 12

Table 1

Confirm that power at the site matches power requirements of the mill before connecting to the power source.

6.3 Voltage conversion

The JTM-1254VS and JTM-1254RVS have been pre-wired for 230 volt operation. To change from 230 to 460 volt operation:

- Remove junction box cover on motor and change wires according to diagram found on inside cover (also shown in Figure 6-1).

Note: In case of discrepancy, diagrams on machine take precedence.

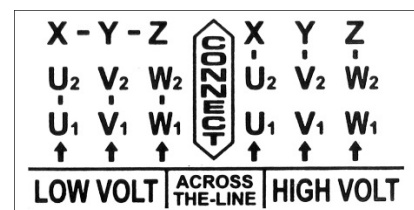

Figure 6-1

2. Change incoming lead on transformer from 230V to 460V terminal (Figure 6-2).
3. Adjust overload relay setting to appropriate amperage (Figure 6-2).

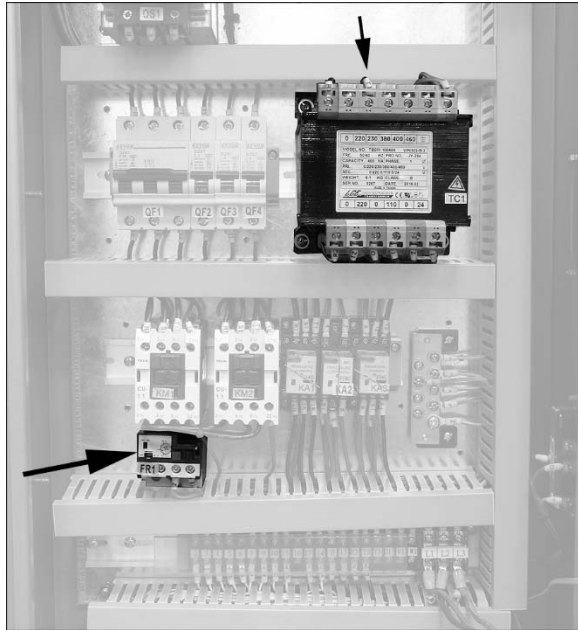

Figure 6-2

Before connecting to power source, make sure that switch is in OFF position.

The mill must be properly grounded.

Check for proper spindle rotation **in the low-speed range**. The spindle should rotate clockwise when viewed from top of machine, and direction switch (A, Figure 8-1) is set to the right. If spindle rotates counterclockwise, disconnect from power and switch two of the three power leads.

7.0 Lubrication

CAUTION Do not operate mill before lubricating the machine fully. Failure to comply may cause damage to machine components.

The milling machine is equipped with an automatic electric lubrication system for leadscrews and ways. Ensure that reservoir has proper amount of lubricant. The system reservoir is located at rear of machine (Figure 7-1).

Use dial (A) to set time interval for shots of lubricant. When machine is turned on, lubricator will send one shot of lubricant through machine, then revert to time interval pre-set by operator.

Press button (B) for three seconds to force-feed oil.

The lubricator remains active as long as milling machine is turned on. To turn off lubricator while mill is on, use top switch (C). **Remember to turn lubricator on before operating machine.**

Refer to *section 10.0* for additional lubricating instructions, before operating machine.

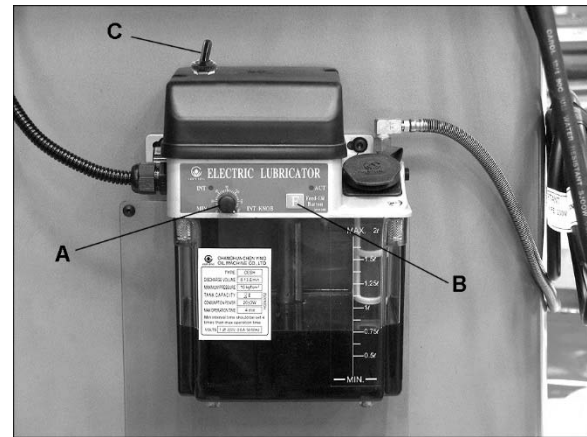

Figure 7-1

8.0 Operating instructions

8.1 Operating controls

The position of mill head can be set up to accommodate the workpiece being machined. The mill head can be set up for angles to left or right. (The JTM-1254RVS also allows fore and aft head movement.) The mill head can also be rotated on its turret. The ram can be moved back and forth to reach workpiece locations at fore and aft extremes of worktable travel. Refer to *section 9.0*.

8.2 Control panel

The control panel is located on the arm at right side of machine. See Figure 8-1 for functions.

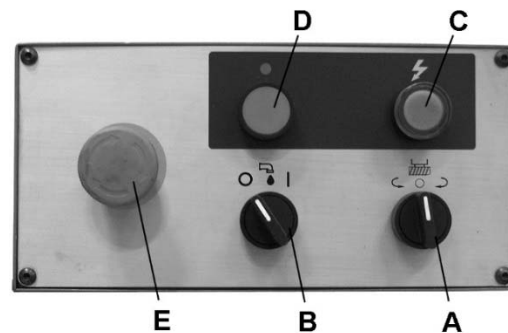

Figure 8-1

A – Spindle (motor) direction switch: Has three positions: right (clockwise rotation), left (counterclockwise rotation) and neutral (spindle stop). Use clockwise rotation for normal, right-hand tooling.

Forward (clockwise) operation occurs only when gearbox is in low speed position. When gearbox is in high-speed position, the motor switch must be in the Reverse position to provide right-hand or clockwise rotation. Refer to Table 2 for required switch positions.

The spindle direction switch controls a three-phase motor. The motor can be switched from forward to reverse and back with the motor running, and will reverse direction when the switch setting is changed. At higher speeds, this may put strain on the timing belt but there will be no damage to motor or gear mechanism. However, it is recommended that switch be placed at neutral position and spindle allowed to come to a stop, then switch moved to opposite direction.

B – **Coolant switch:** Turns on and off coolant pump.

C – **Power on button:** Turns on power to machine.

D – **Spindle off:** turns off spindle rotation.

E – **Emergency stop switch:** Stops all functions on machine. Rotate switch clockwise to disengage and restart machine.

8.3 Control positions for milling and drilling operations

Control \ Action	High/low lever	Quill feed lever	Feed trip cam lever	Quill feed select lever	Feed direction control	Motor switch*
High spindle speeds						REV
Low spindle speeds						FWD
High spindle speeds with automatic downfeed				Select feed rate		REV
Low spindle speeds with automatic downfeed				Select feed rate		FWD
High spindle speeds with automatic upfeed				Select feed rate		REV
Low spindle speeds with automatic upfeed				Select feed rate		FWD
Lever feed						
Fine feed using handwheel						
Free-turning spindle for positioning or working with tooling						

Speeds at Specific Control Settings

Hi/low speed control lever	Range of speeds using control wheel
	80-500 RPM
	500-3800 RPM

* Motor switch position is for right-hand tooling (tooling which requires clockwise rotation of the spindle.) If you are using left-hand tooling, simply change the motor switch to the opposite setting.

Table 2

8.4 Spindle brake

The spindle brake lever (Figure 8-2) is used to stop spindle immediately instead of allowing it to coast to a stop. Pull lever downward to apply brake. To avoid excessive wear on components, first turn off spindle rotation (D, Figure 8-1) before using spindle brake lever.



Figure 8-2

8.5 High-low shift lever

CAUTION Motor must be stopped; turn spindle off (D, Figure 8-1). Do not shift High-Low Lever while motor is running, or damage to gear system may result.

The mill head can be driven directly (High Speed) or through the back gear (Low Speed) in the mill head. Selection is made by changing position of shift lever.

The *shift lever* is located at lower right side of mill head (Figure 8-3). The lever position closest to operator is *High* setting. The lever position away from operator is *Low* setting. The middle position is *Neutral* setting, which allows free spindle rotation for setup work.

Rotate spindle by hand to facilitate engagement of lever.

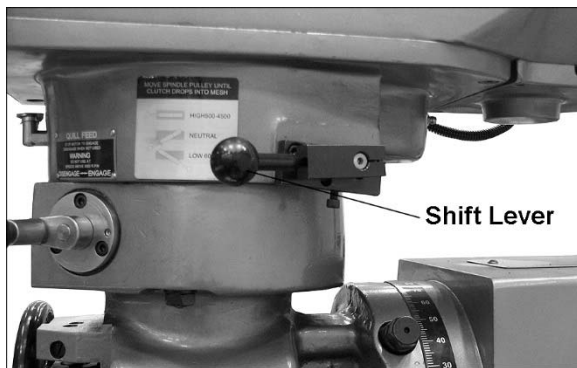

Figure 8-3

8.6 Quill power feed lever

CAUTION Do not use power feed at speeds above 3000 RPM.

CAUTION It is recommended to disengage power feed worm gear whenever power feed is not required. This avoids unnecessary wear on worm gear.

CAUTION Do not move Quill Power Feed Lever unless motor is at complete stop (spindle off – D, Figure 8-1). When changing lever position, do it gently. If gear does not engage, jog motor and allow it to stop before attempting to change.

The quill power feed lever (Figure 8-4) is used to engage and disengage quill power feed mechanism.

The power feed is engaged by pulling out knob and rotating handle to a new locked position. When engaged, power feed mechanism will drive spindle upward or downward. The power feed mechanism will not drive spindle when handle is in disengaged position.



Figure 8-4

8.7 Feed rate lever

The *Feed Rate Lever* (Figure 8-5) is used to set the per-revolution rate of the power feed mechanism. Three feed rates are available: 0.003-inch, 0.008-inch and 0.0015 inch per revolution. The positions are shown on indicator plate beside feed rate lever.

The rate is selected by pulling out knob on feed rate lever and moving handle to detent of desired feed rate. **Note:** Knob is spring loaded – pull out to rotate to new position.

Unlike other controls on the machine, the lever shifts into engagement more easily with the motor running, and the quill feed lever engaged.

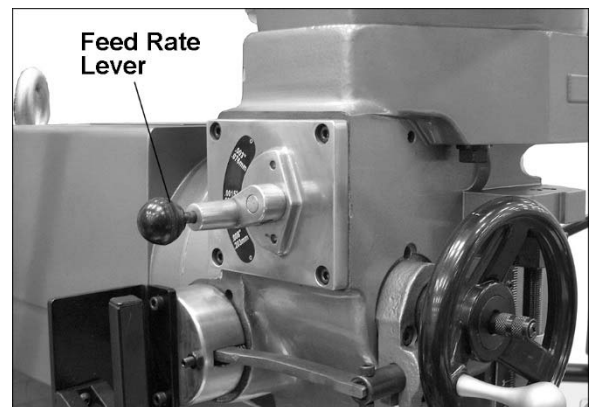

Figure 8-5

8.8 Feed trip cam lever

The *Feed Trip Cam Lever* (A, Figure 8-6) is located behind *Manual Fine Feed Handwheel* (B). It engages the overload clutch on pinion shaft when positioned to the left.

The *Feed Trip Cam Lever* stays engaged until *Quill Stop* (G, Figure 8-8) contacts *Micrometer Adjusting Nut* (F, Figure 8-8) forcing it to drop out automatically, or until it is released manually by pushing lever to the right.

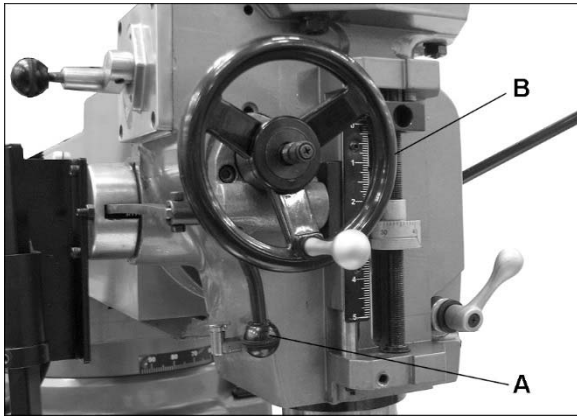

Figure 8-6

8.9 Spindle speed control

While machine is running, turn speed control handwheel (N, Figure 8-9) until desired speed shows on front plate.

CAUTION Do not attempt to change spindle speed unless motor is running.

8.10 Feed direction control

The *Feed Direction Control* (C, Figure 8-7) determines whether power feed will move up, down, or not move at all. The position of knob depends upon direction of spindle rotation (see sect. 8.2, Motor Direction Switch). Position of the control may be changed with the system stopped or running. If the control does not engage easily, move fine feed handwheel (B, Figure 8-7) back and forth to aid engagement.

If spindle is rotating clockwise, *in* is downfeed; *out* is upfeed. If spindle rotation is counterclockwise, *out* is downfeed; *in* is upfeed. Neutral position is between *in* and *out* position.

CAUTION It is recommended that *Feed Direction Control* be left in neutral position when not in use.

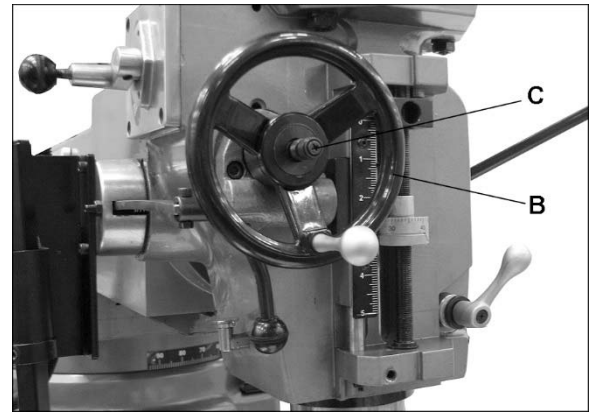

Figure 8-7

8.11 Coarse feed handle

The *Coarse Feed Handle* (D, Figure 8-8) is used for non-precision drilling operations and for moving quill to a specific depth. A return spring will retract spindle once handle is released.

8.12 Quill lock handle

Rotate *Quill Lock Handle* (E, Figure 8-8) clockwise to lock quill in desired position. Rotate handle counterclockwise to release.

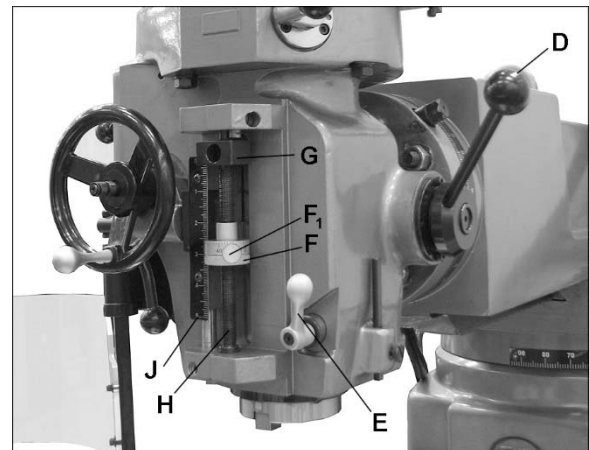

Figure 8-8

8.13 Depth scale and stop

Refer to Figure 8-8:

The *Depth Scale and Stop* are used in drilling operations to set depth of drilled hole. The scale consists of a *Micrometer Adjusting Nut* (F), *Quill Stop* (G), *Quill Stop Screw* (H), and *Scale* (J).

The *Micrometer Adjusting Nut* (F) provides a positive stop for quill travel. Push button (F₁) and slide nut to general position, then rotate nut to specific depth setting.

Graduations on micrometer nut are in 0.001-inch increments.

8.14 Fine feed handwheel

When the controls are set for the *Fine feed using handwheel* position (see Table 2), the *Fine Feed Handwheel* (B, Figure 8-6) can be used for manual fine feed control in either upward or downward direction of quill. Set feed direction control (C, Figure 8-7) at neutral position.

WARNING Remove manual fine feed handwheel when not in use. Failure to comply may cause injury.

8.15 Automatic feed operation

Feed trip adjustment sets the point at which quill will reset during automatic feed.

Refer to Figure 8-9.

WARNING Remove manual fine feed handwheel before power feed operation. Failure to comply may cause injury.

1. Move micrometer adjusting nut to allow for ample spindle travel.
2. Use *Coarse Feed Handle* (D) to advance quill to point where the feed should stop. Lock quill (E).
3. Engage *Feed Trip Cam Lever* (A) by pulling away from head assembly.
4. Move *Micrometer Adjusting Nut* (F) against *Quill Stop* (G).
5. Continue turning *Micrometer Adjusting Nut* (F) until *Feed Trip Cam Lever* (A) trips.
6. Loosen *Quill Lock* (E) to allow quill to retract.
7. Set *Feed Rate Lever* (K) to feed rate required for tooling and material.
8. Select feed direction by setting *Feed Direction Knob* (C) position per Table 3:

Spindle Direction	Feed Direction	Knob Position
CW	Down	In
	Up	Out
CCW	Down	Out
	Up	In

Table 3

9. Place *Quill Feed Engagement Lever* (L) in *Engaged* position.
10. Turn on spindle.
11. Engage *Feed Trip Cam Lever* (A) by pulling away from head assembly. Feed will begin until lever trips out at preset depth.

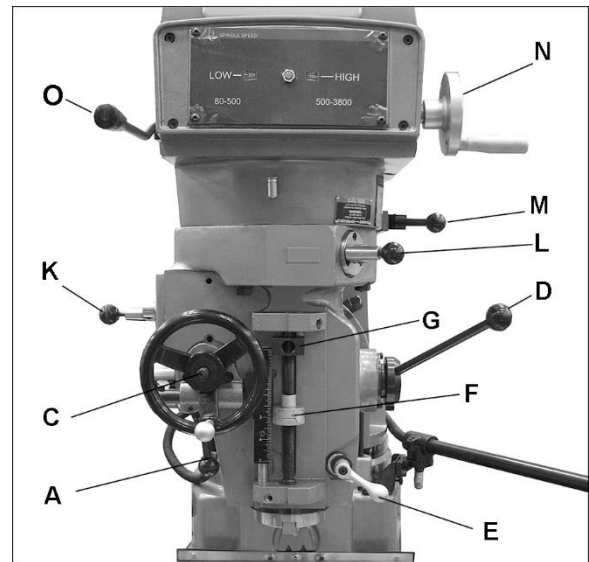

Figure 8-9

Note: Due to variables in tool diameter, coatings, coolant, and materials, no specific spindle speed or feed rate recommendations are provided. Use general shop manuals that have data applicable to the milling and drilling operations being performed. Or, contact the supplier of the tooling, coolant, and material for specific recommendations.

IMPORTANT: The power feed can be used for drills up to 3/8" in diameter (mild steel). Use manual feed for drills larger than 3/8".

CAUTION The overload clutch is factory set to hold up to 200 lbs. downfeed pressure on the quill (accommodates drills up to 3/8"). Do not attempt to adjust clutch pressure.

8.16 Draw bar operation – changing tooling

1. Lock spindle using spindle brake (O, Figure 8-9).
2. Using provided wrench on drawbar hexagonal end (Figure 8-10), loosen draw bar two or three turns counterclockwise.

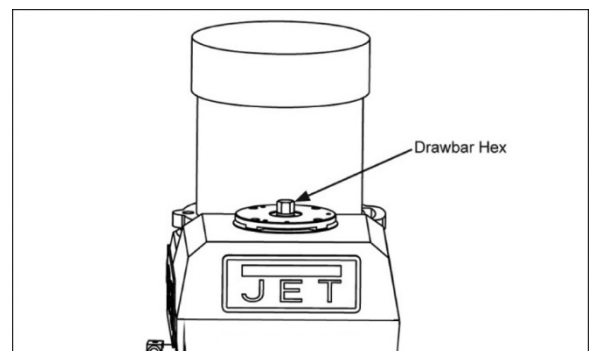

Figure 8-10

3. Tap the top of draw bar with a soft-faced hammer to loosen collet from taper.
4. Remove tool from collet.
5. Insert new tool into collet.

6. Tighten draw bar firmly using provided wrench. Turn draw bar. The tool is now ready for use.

8.17 Clamping workpiece to table

The worktable has 5/8-inch T-slots for clamping workpiece to table.

1. Set motor switch to neutral (stop) position.
2. Place workpiece on table.
3. Clamp workpiece using T-slot clamps, studs, and step blocks as required (Figure 8-11).

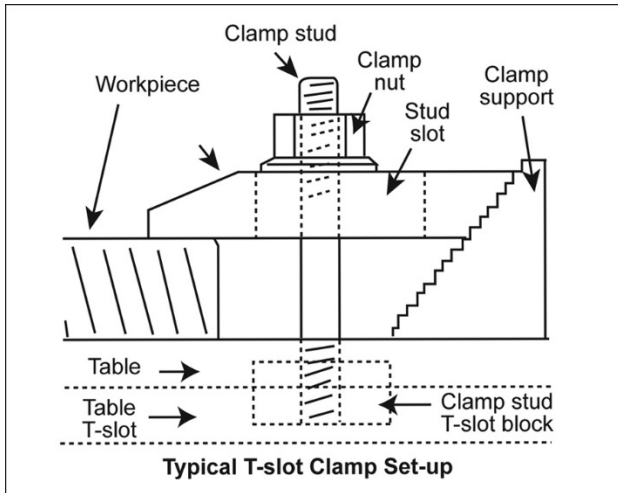

Figure 8-11

9.0 Adjustments

9.1 Mill head – left/right adjustment

⚠WARNING Make sure machine base is secured to floor before repositioning mill head. The center of gravity can shift enough to cause machine to tip over, resulting in serious injury to operator and damage to machine.

1. Loosen four large hex nuts that secure mill head to ram adapter (A, Figure 9-1). One-quarter (1/4) turn should be sufficient to allow head to move.

NOTE: For angles greater than 10 degrees, use your free hand to support mill head, taking some weight off the brass worm gears. Doing so will greatly lengthen life of worm gears.

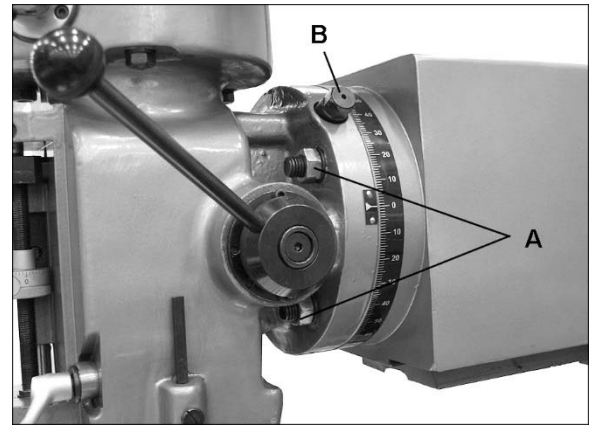

Figure 9-1

2. Turn worm nut (B, Figure 9-1) to tilt head left or right as required. Use scale on ram adapter to set desired angle.

Note: Scales on ram adapter and for head rotation are guides only. Close tolerance work will require use of a dial indicator to make sure head is 90° to table in X and Y axis. Please note the table is fitted to be slightly higher in front, usually about 0.0005”.

3. Tighten the four hex nuts. Tighten in two steps using a calibrated torque wrench. Use a crossing pattern to tighten the nuts. Tighten initially to 25 foot-pounds.

⚠CAUTION Apply torque in two steps using a crossing pattern. Failure to do so could distort face of ram adapter.

4. Before applying final torque, check to make sure mill head is perpendicular to work table.
5. Set up a dial indicator in a collet and secure using draw bar (refer to Figure 9-2).
6. Put spindle drive in neutral.
7. Set dial indicator plunger on work table. Zero indicator.
8. Rotate spindle 180 degrees (when rotating, raise dial indicator plunger by hand to prevent it from dropping into table T-slots).
9. Read dial indicator – it should read zero. If not, loosen the four hex nuts and reposition mill head.

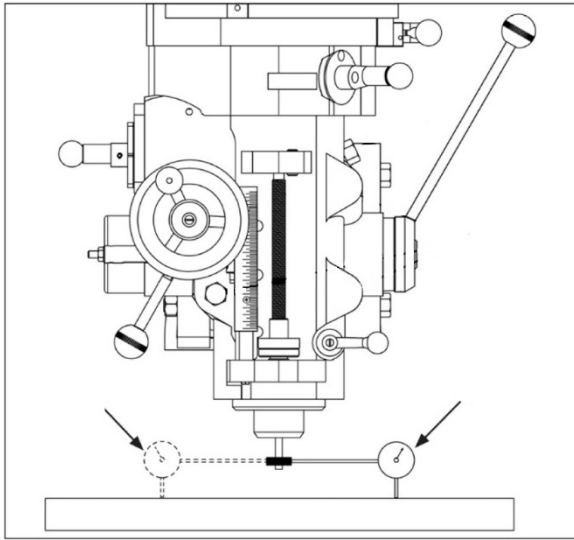

Figure 9-2

10. Recheck perpendicularity using the dial indicator. Repeat above procedure until dial indicator reads zero in both positions.
11. Tighten the four hex nuts. Tighten in two steps using a calibrated torque wrench. Use a crossing pattern to tighten the nuts. Tighten initially to 25 foot-pounds, then tighten to a final torque of 50 foot-pounds.

CAUTION Apply torque in two steps using a crossing pattern. Failure to do so could distort face of ram adapter.

9.2 Positioning ram

9.2.1 Positioning ram fore and aft

1. Loosen two ram lock bolts (C, Figure 9-3) that lock the ram to its ways.
2. Turn ram pinion (D) with a wrench to slide ram on its ways.
3. When desired position is reached, tighten ram lock bolts (C) securely.

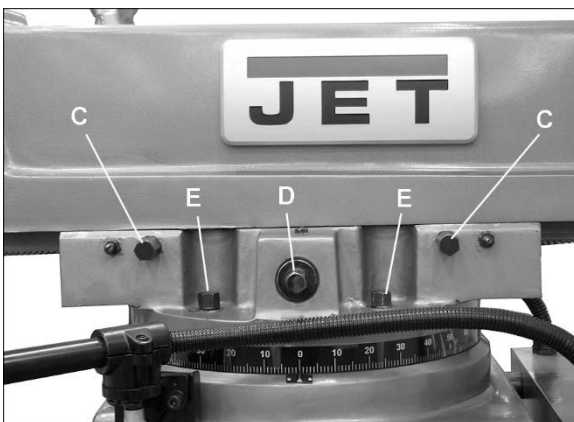

Figure 9-3

9.2.2 Positioning ram on turret

WARNING Make sure machine base is secured to floor before repositioning ram. The center of gravity can shift enough to cause machine to tip over, resulting in serious injury to operator and damage to machine.

1. Loosen four turret lock bolts (E, Figure 9-3) that clamp the ram to the top of the base. One-half (1/2) turn should be sufficient to allow turret to move.

Note: Use gentle hand pressure to avoid rapid movement.

2. Turn ram until spindle is in desired position. Use scale on turret for degree measurement.
3. Tighten four turret lock bolts (E). Tighten in two steps using a calibrated torque wrench. Use a crossing pattern to tighten the nuts. Tighten initially to 25 foot-pounds, then tighten to a final torque of 50 foot-pounds.

9.3 Gib adjustment

The table, saddle and knee are equipped with adjustable gibs. The gibs may require adjustment if unusual vibration is noted when the locking mechanisms are off, or if you experience unusual vibration when spindle speed, tooth pitch or depth of cut do not account for the vibration.

NOTE: When adjusting gibs, always start with knee first; adjust saddle second, and adjust table last.

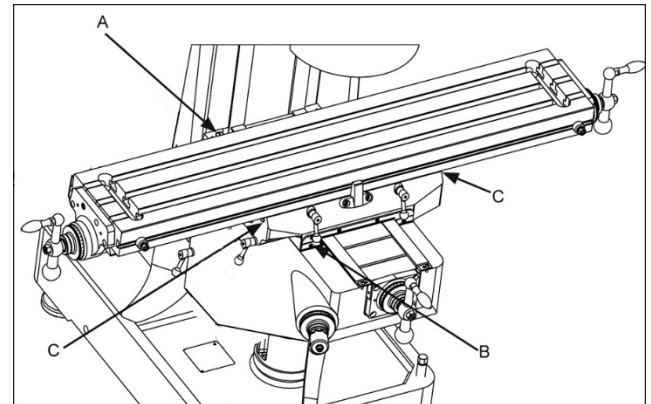

Figure 9-4

9.3.1 Knee gib adjustment

The knee gib adjustment screw (A, Figure 9-4) is located under chip wiper at rear of knee where it contacts column. Remove way cover and wiper to expose gib adjustment screw. Tighten screw until slight drag is felt when turning knee crank.

9.3.2 Saddle gib adjustment

The saddle gib adjustment screw is on left front of saddle (B, Figure 9-4). Tighten screw until slight drag is felt when turning cross-feed crank.

9.3.3 Table gib adjustment

Table gib adjustment screws (C, Figure 9-4) are beneath table. Tighten screws until slight drag is felt when turning longitudinal table cranks.

9.4 Power feed trip lever mechanism

Refer to Figure 9-5.

The power feed trip lever mechanism will require adjustment if worn or whenever any trip lever mechanism components are replaced.

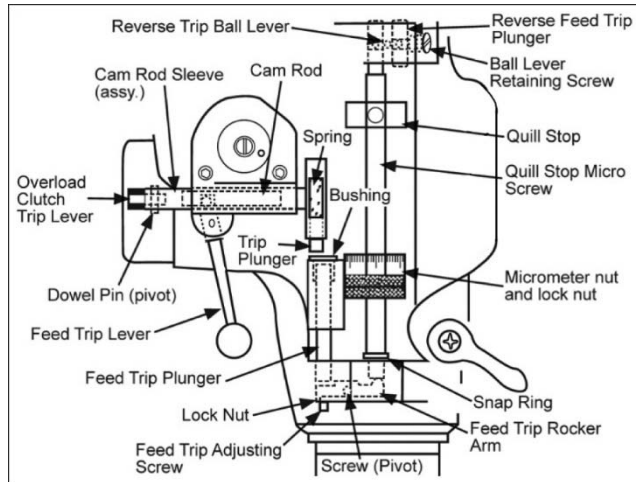

Figure 9-5

1. Loosen feed trip adjusting screw lock nut.
2. Loosen adjusting screw until it is loose in the lever and no longer contacts bottom of feed trip plunger.
3. Using the coarse feed handle, move quill to bottom of its travel so that quill stop contacts micrometer nut. Hold the quill on the stop.
4. Pull feed handle out to engage power feed system.
5. Turn feed trip adjusting screw until power feed disengages.
6. Tighten feed trip adjusting screw.
7. Release quill stop so you can engage power feed mechanism using power feed trip lever.
8. Using the coarse feed handle, pull quill stop back into firm contact with micrometer nut.
Note: The power feed should disengage when the quill stop pushes on the micrometer nut. If it does not disengage, repeat the adjustment steps above.
9. Engage power feed and move quill stop to top of its travel. Make sure that reverse trip mechanism also disengages power feed. If it does not, readjust the mechanism until positive disengagement occurs when quill is at top of its stroke.
10. Check for correct operation using coarse feed handle. If operating correctly, start drive motor and engage power feed mechanism. Verify that power

feed lever correctly engages and disengages when driven by drive motor.

9.5 Table lead screw backlash adjustment

Refer to Figure 9-6.

The milling machine table is moved by a lead screw and nut for each machine axis. For proper operation, there must be clearance between lead screw and nut, which results in backlash. A second lead screw nut is provided to eliminate most of the backlash. The following procedures provide instructions for obtaining acceptable backlash.

9.5.1 Cross feed backlash adjustment

1. Use cross feed crank to move table to extreme rear of its travel.
2. Remove pleated way cover.
3. Open the two chip guards enough to expose cross-feed adjustment nut (the nut that is toward the rear of the nut bracket is not adjustable – only the front nut is adjustable).
4. Loosen the two nut locking screws.
5. Turn nut slightly to tighten it against opposing nut.
6. Tighten the two nut locking screws.
7. Using the cross-feed crank, move table to middle position.
8. Set up a dial indicator to check cross-feed backlash. Gently move cross feed crank back and forth while watching dial indicator. Backlash should be between 0.003 inch and 0.005 inch.
9. If necessary, repeat the steps above to set backlash.
10. Install pleated way cover.

9.5.2 Longitudinal backlash adjustment

Refer to Figure 9-6.

1. Only one of the longitudinal lead screw nuts can be adjusted. The other nut is fixed. The left hand nut is typically adjustable. This can be determined by looking at nut from underside of table.
2. Loosen the two nut locking screws.
3. Turn nut slightly to tighten it against opposing nut.
4. Tighten the two nut locking screws.
5. Using the longitudinal table crank, move table to middle position.
6. Set up a dial indicator to check longitudinal backlash. Gently move crank back and forth while watching dial indicator. The backlash should be between 0.003 inch and 0.005 inch.

If necessary, repeat the steps above to set backlash.

Table Lead Screw Components

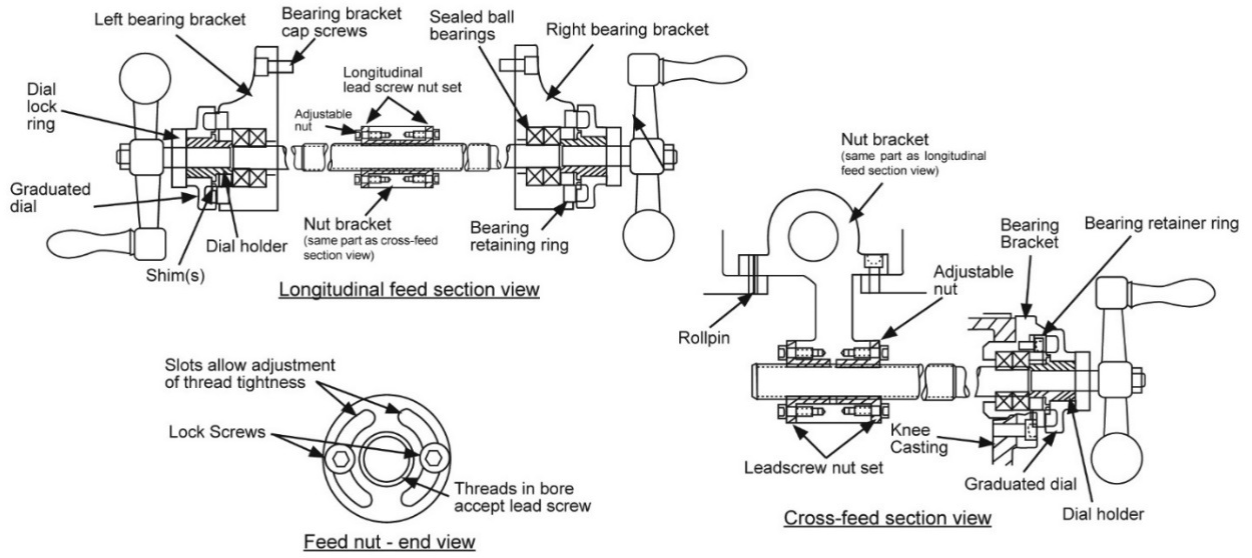

Figure 9-6

10.0 User-maintenance

⚠WARNING Before any intervention on the machine, disconnect it from electrical supply by pulling out plug or switching off main switch. Failure to comply may cause serious injury.

10.1 Lubrication

The milling machine is equipped with an automatic lubrication system. The system lubricates lead screws and ways. Oil cups and grease fittings on mill head provide lubrication for spindle bearings and back gear mechanism. Refer to Figures 10-1 through 10-4 for lubrication requirements and access points.

Key	Description	Recommended Lubricant	Action
A	Spindle bearing oil cup	Mobil DTE Oil Light, or equivalent	Service daily.
B	Automatic lube system (see also sect. 7.0)	Mobil Vactra Oil #2, or equivalent	Check oil daily – add if required.
C	Knee leadscrew grease fitting	Mobilith AW2, or equivalent	Service once each week.
D	Back gear grease fitting	Mobilith AW1, or equivalent	Service weekly when operating in back gear mode.

Table 4: Lubrication Points

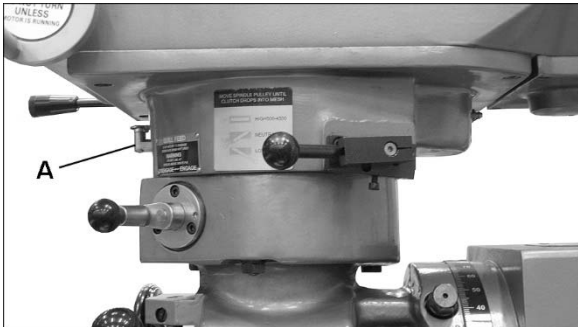

Figure 10-1

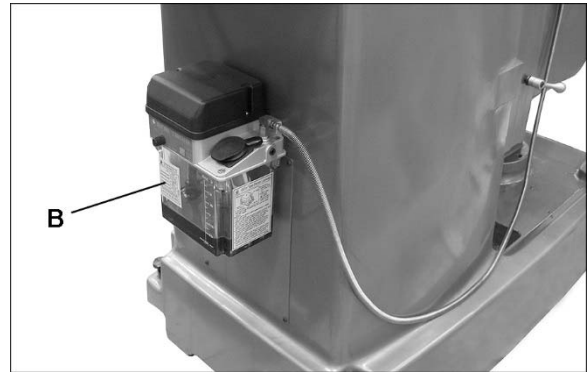

Figure 10-3

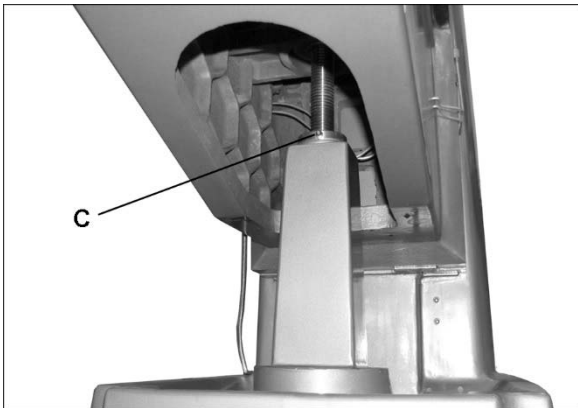

Figure 10-2

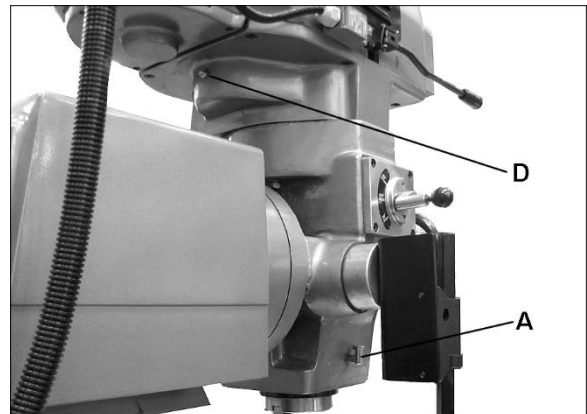

Figure 10-4

10.2 Periodic maintenance requirements

During operation, periodically vacuum and brush chips and debris from machine.

Operate knee and table lead screws through full range of movement to evenly distribute lubricant.

Apply light machine oil to work table and other exposed metal surfaces to prevent rust or corrosion.

Remove vent panels to check pulleys and belts for unusual wear or grooving. *NOTE: Operators should vary speed occasionally to prevent formation of grooves on pulley surfaces.*

11.0 Recommended speed for mill and drill operations

Mill cutting speed recommended (mm/min)

$$V = \pi DN / 1000$$

V cutting speed (mm/min)		
<i>Material</i>	<i>Heavy cutting</i>	<i>Processing cutting</i>
Cast iron	30-40	45-90
Malleable iron	37-45	45-90
Steel (soft)	60-90	75-105
Steel (medium)	45-67	52-75
Steel (hard)	24-37	55-75
Cast steel	24-30	55-75
Aluminum	240-300	300-360
Brass	105-180	150-300
Bronze	52-75	75-90
Magnesium alloy	240-300	300-600
Zinc alloy	120-240	210-450
Drill speed (RPM) recommended		
5mm hole	1000-1500	
10mm hole	500-800	
13mm	300-500	
20mm	150-300	

Table 5

12.0 Replacement parts

Replacement parts are listed on the following pages. To order parts or reach our service department, call 1-800-274-6848 Monday through Friday, 8:00 a.m. to 5:00 p.m. CST. Having the Model Number and Serial Number of your machine available when you call will allow us to serve you quickly and accurately.

Non-proprietary parts, such as fasteners, can be found at local hardware stores, or may be ordered from JET.

Some parts are shown for reference only, and may not be available individually.

12.1.1 JTM-1254VS Upper Head Assembly – Exploded View

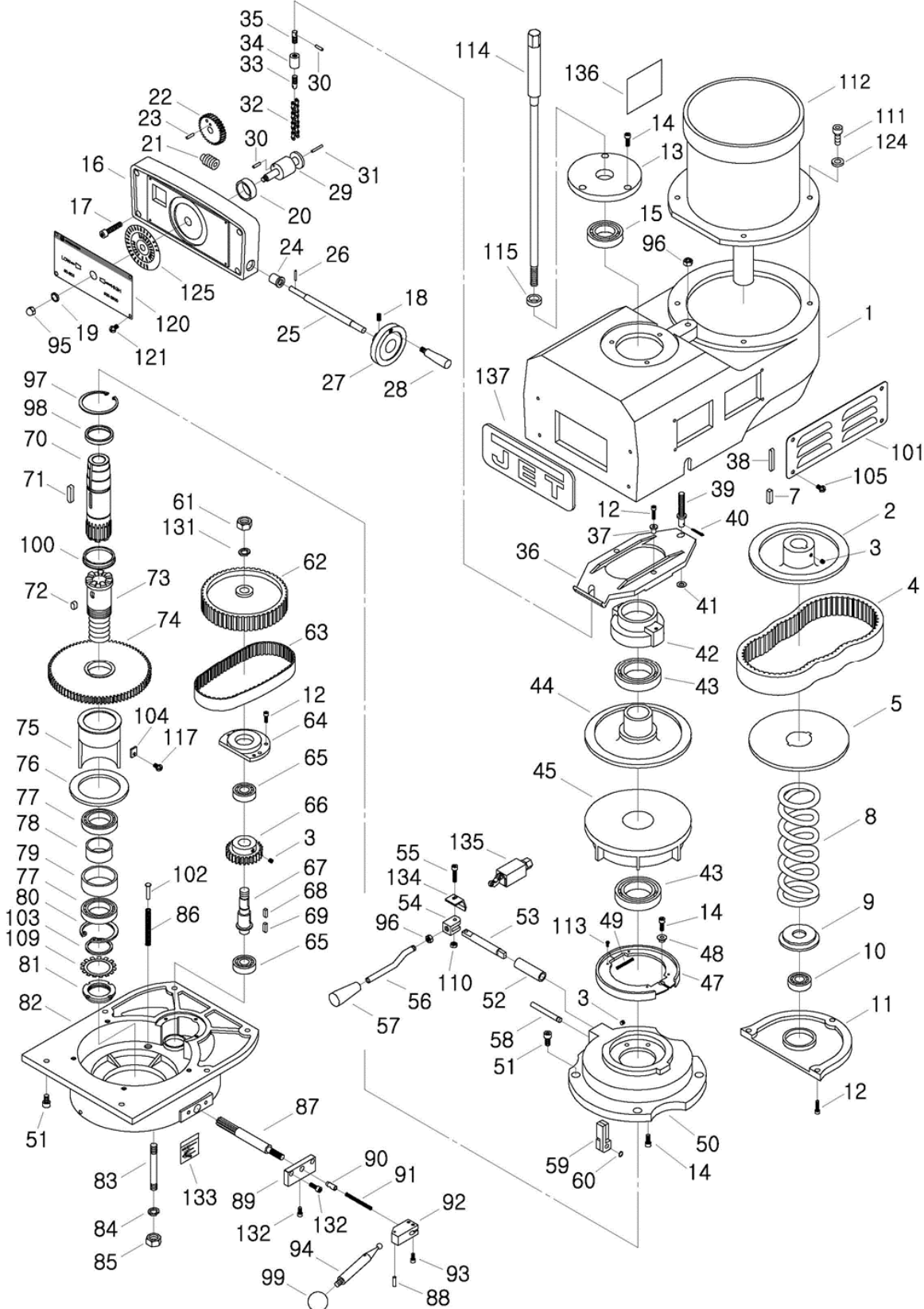

12.1.2 JTM-1254VS Upper Head Assembly – Parts List

Index No	Part No	Description	Size	Qty
1	JTM1254VS-A01	Upper Pulley Housing		1
2	JTM1254VS-A02	Motor Disc - Upper		1
3	TS-1523011	Set Screw	M6x6L	4
4	JTM1254VS-A04	Belt		1
5	JTM1254VS-A05	Motor Disc - Lower		1
7	6295247	Key	7x7x25L	1
8	JTM1254VS-A08	Spring		1
9	JTM1254VS-A09	Washer		1
10	BB-6204ZZ	Ball Bearing	6204ZZ	1
11	JTM1254VS-A11	Pulley Cover		1
12	TS-1503041	Hex Socket Cap Screw	M6x16L	4
13	JTM1254VS-A13	Upper Cover		1
14	TS-1503041	Hex Socket Cap Screw	M6x16L	10
15	BB-6009ZZ	Ball Bearing	6009ZZ	1
16	JTM1254VS-A16	Dial Housing		1
17	TS-1503071	Hex Socket Cap Screw	M6x30L	4
18	TS-1523051	Set Screw	M6x16L	2
19	JTM1254VS-A19	Bushing		1
20	JTM1254VS-A20	Spacer		1
21	JTM1254VS-A21	Worm		1
22	JTM1254VS-A22	Worm Gear		1
23	5301041	Spring Pin	Ø5x10L	2
24	JTM1254VS-A24	Bushing		2
25	JTM1254VS-A25	Shaft		1
26	5302611	Spring Pin	Ø3x12L	1
27	JTM1254VS-A27	Handwheel		1
	JTM1254VS-A27A	Handwheel Assembly (includes #18,27,28)		1
28	JTM1254VS-A28	Handle		1
29	JTM1254VS-A29	Chain Axle		1
30	5509313	Spring Pin	Ø4x16L	2
31	GA7X-865	Spring Pin	Ø3x25L	1
32	JTM1254VS-A32	Chain		1
33	JTM1254VS-A33	Screw		1
34	JTM1254VS-A34	Spacer		1
35	JTM1254VS-A35	Pin		1
36	JTM1254VS-A36	Adjustable Plate		1
37	JTM1254VS-A37	Shift Sleeve		2
38	6294761	Key	6x6x45L	1
39	JTM1254VS-A39	Bottom Pin		1
40	5307431	Spring Pin	3/32"x3/4"	1
41	JTM1254VS-A41	Flat Washer	Ø8.5	1
42	JTM1254VS-A42	Bearing Housing		1
43	BB-6010ZZ	Ball Bearing	6010ZZ	2
44	JTM1254VS-A44	Spindle Disc - Upper		1
45	JTM1254VS-A45	Spindle Disc - Lower		1
47	JTM1254VS-A47	Brake Lining		1
48	JTM1254VS-A48	Lock Collar		1
49	JTM1254VS-A49	Spring		1
50	JTM1254VS-A50	Brake Seat		1
51	TS-1504041	Hex Socket Cap Screw	M8x20L	10
52	JTM949EVS-A53	Brake Sleeve		1
53	JTM949EVS-A54	Spindle Brake Shaft		1
54	JTM949EVS-A56	Spindle Brake Lever Pivot		1
55	TS-1503071	Hex Socket Cap Screw	M6x30L	1
56	JTM1254VS-A56	Spindle Brake Lever		1
57	JTM949EVS-A50	Brake Lever Knob	3/8"	1
58	JTM1254VS-A58	Hand Rod		1
59	JTM1254VS-A59	Brake Bracket		1
60	JTM949EVS-A46	Retaining Ring	STW8	1
61	TS-0561072	Hex Nut	5/8-18UNF	1

Index No	Part No	Description	Size	Qty
62	JTM1254VS-A62	Timing Wheel		1
63	JTM1254VS-A63	Timing Belt		1
64	JTM1254VS-A64	Bearing Seat		1
65	BB-6203ZZ	Ball Bearing	6203ZZ	2
66	JTM1254VS-A66	Pinion		1
67	JTM1254VS-A67	Gear Shaft		1
68	KF2R5515	Double Round Key	5x5x15L	1
69	KF2R5518	Double Round Key	5x5x18L	1
70	JTM1254VS-A70	Input Clutch		1
71	5307741	Key	8x7x24L	1
72	KF2R8712	Key	8x7x12L	1
73	JTM1254VS-A73	Output Clutch		1
74	JTM1254VS-A74	Gear		1
75	JTM1254VS-A75	Bearing Housing		1
76	JTM1254VS-A76	Washer		1
77	BB-6912ZZ	Ball Bearing	6912ZZ	2
78	JTM1254VS-A78	Spacer (Small)		1
	JTM1254VS-A78A	Gear Bearing Spacer Assembly (includes #78,79)		1
79	JTM1254VS-A79	Spacer (Large)		1
80	RTW62	Retaining Ring	RTW62	1
81	AN08	Bearing Nut	AN08	1
82	JTM1254VS-A82	Upper Pulley Housing		1
83	JTM1254VS-A83	Stud	7/16x4"	3
84	TS-0720101	Spring Washer	7/16"	3
85	TS-0561041	Hex Nut	7/16"	3
86	JTM1254VS-A86	Spring		3
87	JTM949EVS-A03	Bull Gear Shifter Pinion Shaft		1
88	B-56	Spring Pin	Ø3x20L	1
89	JTM949EVS-A04	Hi-Lo Detent Plate		1
90	JTM949EVS-A05	Sleeve		1
91	JTM949EVS-A06	Spring		1
92	JTM949EVS-A08	Hi-Lo Pinion Block		1
93	TS-1502031	Hex Socket Cap Screw	M5x12	2
94	JTM949EVS-A09	Hi-Lo Shift Handle		1
95	F004478	Cap Nut	5/16"-18UNC	1
96	TS-0570031	Hex Nut	3/8"-16UNC	2
97	RTW80	Retaining Ring	RTW80	1
98	JTM1254VS-A98	Collar		1
99	BH1/4	Black Plastic Ball	1/4"	1
100	JTM1254VS-A100	Clutch Collar		1
101	JTM1254VS-A101	Pulley Cover		2
102	JTM1254VS-A102	Spring Shaft		3
103	JTM1254VS-A103	Spacer		1
104	JTM1254VS-A104	Square Nut		1
105	5712561	Pan Head Screw	M5x8L	8
109	AW08	Bearing Washer	AW08	1
110	TS-1540041	Nut	M6	1
111	TS-1209051	Hex Socket Cap Screw	3/8"x1"L	4
112	JTM1254VS-A112	Motor	3.75kW,5 HP,3Ph	1
	JTM1254VS-A112-1	Motor Fan (not shown)		1
	JTM1254VS-A112-2	Motor Fan Cover (not shown)		1
	JTM1254VS-A112-3	Junction Box Cover (not shown)		1
113	JTM949EVS-A51	Pan Head Screw	1/8"x1/4"L	4
114	JTM1254VS-A114	Draw Bar	5/8"	1
115	JTM1254VS-A115	Spacer		1
117	VS-117	Pan Head Screw	3/16"x1/2"L	1
120	JTM1254VS-A120	Speed Plate		1
121	TS-2284202	Pan Head Screw	M4x20L	4
124	TS-1550071	Flat Washer	Ø10mm	4
125	JTM1254VS-A125	Speed Dial		1
131	TS-0720131	Spring Washer	5/8"	1
132	TS-1502041	Hex Socket Cap Screw	M5x16L	3

Index No	Part No	Description	Size	Qty
133	LM000005	Speed Range Label		1
134	JTM949EVS-A91	Push Plate		1
135	JTM949EVS-A92	Limit Switch		1
136	LM000182	Motor Label		1
137	JET-165	JET Logo	165x68 mm	1

12.2.1 JTM-1254RVS (R8) Upper Head Assembly – Exploded View

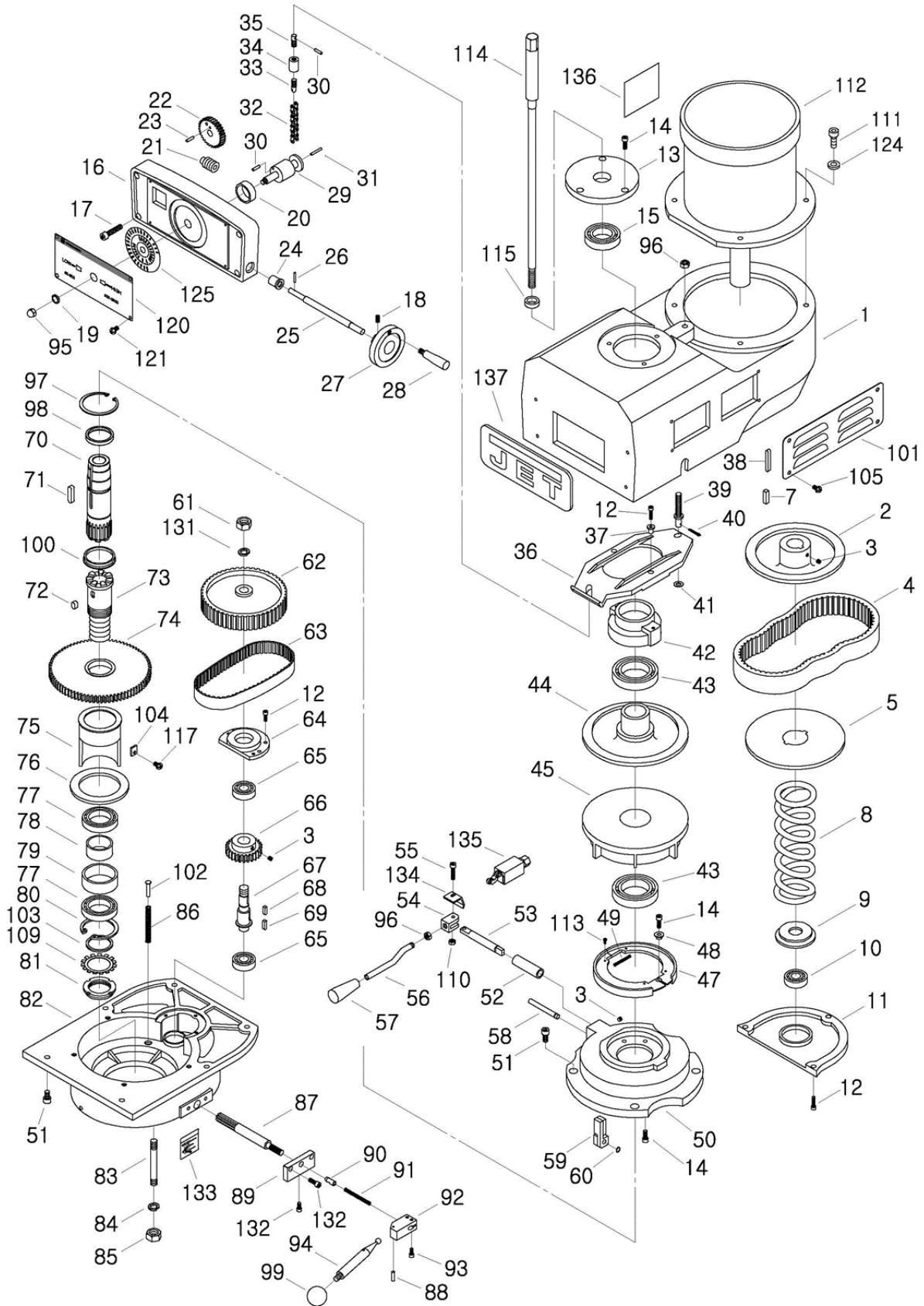

12.2.2 JTM-1254RVS (R8) Upper Head Assembly – Parts List

Index No	Part No	Description	Size	Qty
1	JTM949EVS-A77	Upper Pulley Housing		1
2	JTM1254RVS-A02	Motor Disc - Upper		1
3	TS-1523011	Set Screw	M6x6L	4
4	JTM1254RVS-A04	Belt		1
5	JTM1254RVS-A05	Motor Disc - Lower		1
7	6295247	Key	7x7x25L	1
8	JTM1254RVS-A08	Spring		1
9	JTM1254RVS-A09	Washer		1
10	BB-6204ZZ	Ball Bearing	6204ZZ	1
11	JTM949EVS-A69	Motor Pulley Cover		1
12	TS-1504041	Hex Socket Cap Screw	M8x20	3
13	JTM1254RVS-A13	Upper Cover		1
14	TS-1502041	Hex Socket Cap Screw	M5x16	10
15	BB-6009ZZ	Ball Bearing	6009ZZ	1
16	JTM1254RVS-A16	Dial Housing		1
17	TS-1503071	Hex Socket Cap Screw	M6x30L	4
18	TS-1523051	Set Screw	M6x16L	2
19	JTM1254RVS-A19	Bushing		1
20	JTM1254RVS-A20	Spacer		1
21	JTM1254RVS-A21	Worm Gear Shaft		1
22	JTM1254RVS-A22	Worm Gear		1
23	5301041	Spring Pin	Ø5x10L	2
24	PS3L12	Bushing		2
25	PS4L16	Shaft		1
26	5302611	Spring Pin	Ø3x12L	1
27	JTM1254RVS-A27	Handwheel		1
	JTM1254RVS-A27A	Handwheel Assembly (includes #18,27,28)		1
28	JTM1254RVS-A28	Grip		1
29	JTM1254RVS-A29	Chain axle		1
30	5509313	Spring Pin	Ø4x16L	2
31	GA7X-865	Spring Pin	Ø3x25L	1
32	JTM1254RVS-A32	Chain		1
33	JTM1254RVS-A33	Screw		1
34	JTM1254RVS-A34	Spacer		1
35	JTM1254RVS-A35	Jointer		1
36	JTM1254RVS-A36	Adjustable Plate		1
37	JTM1254RVS-A37	Shift Sleeve		2
38	6294761	Key	6x6x45L	1
39	JTM1254RVS-A39	Regulating Screw		1
40	5307431	Spring Pin	3/32"x3/4"	1
41	JTM1254RVS-A41	Flat Washer	Ø8	1
42	JTM1254RVS-A42	Bearing Housing		1
43	BB-6010ZZ	Ball Bearing	6010ZZ	2
44	JTM1254RVS-A44	Spindle Disc - Upper		1
45	JTM1254RVS-A45	Spindle Disc - Lower		1
47	JTM949EVS-A48	Brake Shoe		1
48	JTM949EVS-A58	Lock Collar		1
49	JTM949EVS-A62	Brake Spring		1
50	JTM949EVS-A43	Brake Base		1
51	TS-1504041	Hex Socket Cap Screw	M8x20L	10
52	JTM949EVS-A53	Brake Sleeve		1
53	JTM949EVS-A54	Spindle Brake Shaft		1
54	JTM949EVS-A56	Spindle Brake Lever Pivot		1
55	TS-1503071	Hex Socket Cap Screw	M6x30	1
56	JTM949EVS-A63	Spindle Brake Lever		1
57	JTM949EVS-A50	Brake Lock Knob	3/8"	1
58	JTM949EVS-A49	Brake Shaft		1
59	JTM949EVS-A47	Brake Finger Stud (set of 2)		1
60	JTM949EVS-A46	Retaining Ring	STW8	1
61	JTM1254RVS-A61	Hex Nut	5/8-18UNF	1

Index No	Part No	Description	Size	Qty
62	JTM949EVS-A34	Timing Pulley		1
63	JTM949EVS-A32	Timing Belt	225L100	1
64	JTM949EVS-A19	Ball Bearing Bracket		1
65	BB-6203ZZ	Ball Bearing	6203ZZ	2
66	JTM949EVS-A18	Gear		1
67	JTM949EVS-A16	Gear Shaft		1
68	KF2R5515	Double Round Key	5x5x15L	1
69	KF2R5518	Double Round Key	5x5x18L	1
70	JTM949EVS-A41	Input Clutch		1
71	JTM949EVS-A40	Key	8x7x24L	1
72	KF2R8712	Key	8x7x12L	1
73	JTM949EVS-A38	Output Clutch		1
74	JTM949EVS-A33	Gear		1
75	JTM949EVS-A31	Bearing Sleeve		1
76	JTM949EVS-A30	Washer		1
77	BB-6908ZZ	Ball Bearing	6908ZZ	2
78	JTM949EVS-A29	Gear Bearing Spacer (Small)		1
79	JTM949EVS-A28	Gear Bearing Spacer (Large)		1
79A	JTM949EVS-A28A	Gear Bearing Spacer Assembly (#78,79)		1
80	RTW62	Retaining Ring	RTW62	1
81	AN08	Bearing Nut	AN08	1
82	JTM949EVS-A01	Upper Pulley Housing		1
83	JTM949EVS-A88	Stud	7/16"x4"	3
84	TS-0720101	Spring Washer	7/16"	3
85	TS-0561041	Hex Nut	7/16"	3
86	JTM949EVS-A21	Pressure Spring		3
87	JTM949EVS-A03	Bull Gear Shifter Pinion Shaft		1
88	B-56	Spring Pin	Ø3x20L	1
89	JTM949EVS-A04	Hi-Lo Detent Plate		1
90	JTM949EVS-A05	Sleeve		1
91	JTM949EVS-A06	Spring		1
92	JTM949EVS-A08	Hi-Lo Pinion Block		1
93	TS-1502031	Hex Socket Cap Screw	M5x12L	2
94	JTM949EVS-A09	Hi-Lo Shift Handle		1
95	F004478	Cap Nut	5/16"-18UNC	1
96	TS-0570031	Hex Nut	3/8"-16UNC	2
97	JTM949EVS-A42	Retaining Ring	STW80	1
98	JTM949EVS-A59	Collar		1
99	BH1/4	Black Plastic Ball	1/4"	1
100	JTM949EVS-A39	Clutch Collar		1
101	JTM949EVS-A75	Side Belt Housing Cover		2
102	JTM949EVS-A22	Spring Shaft		3
103	JTM949EVS-A25	Spacer		1
104	JTM1254RVS-A104	Nut		1
105	JTM1254VS-A105	Pan Head Screw	M5x8L	4
109	AW08	Bearing Washer	AW08	1
110	TS-1540041	Nut	M6	1
111	TS-1505031	Hex Socket Cap Screw	M10x25	4
112	JTM1254VS-A112	Motor	5HP (3.75kW)	1
	JTM1254VS-A112-1	Motor Fan (not shown)		1
	JTM1254VS-A112-2	Motor Fan Cover (not shown)		1
	JTM1254VS-A112-3	Junction Box Cover (not shown)		1
113	JTM949EVS-A51	Pan Head Screw	1/8"x1/4"	4
114	JTM949EVS-A87	Draw Bar	7/16"	1
115	JTM949EVS-A86	Spacer		1
117	VS-117	Pan Head Screw	3/16"x1/2"L	1
120	JTM1254VS-A120	Speed Plate		1
121	TS-2284202	Pan Head Screw	M4x20L	4
124	TS-1550071	Flat Washer	Ø10	4
125	JTM1254VS-A125	Speed Dial		1
131	TS-0720131	Spring Washer	5/8"	1
132	TS-1502041	Hex Socket Cap Screw	M5x16	3

Index No	Part No	Description	Size	Qty
133	LM000005	Speed Range Label		1
134	JTM949EVS-A91	Push Plate		1
135	JTM949EVS-A92	Limit Switch		1
136	LM000182	Motor Label		1
137	JET-165	JET Logo	165x68 mm	1

12.3.1 JTM-1254VS Lower Head Assembly – Exploded View

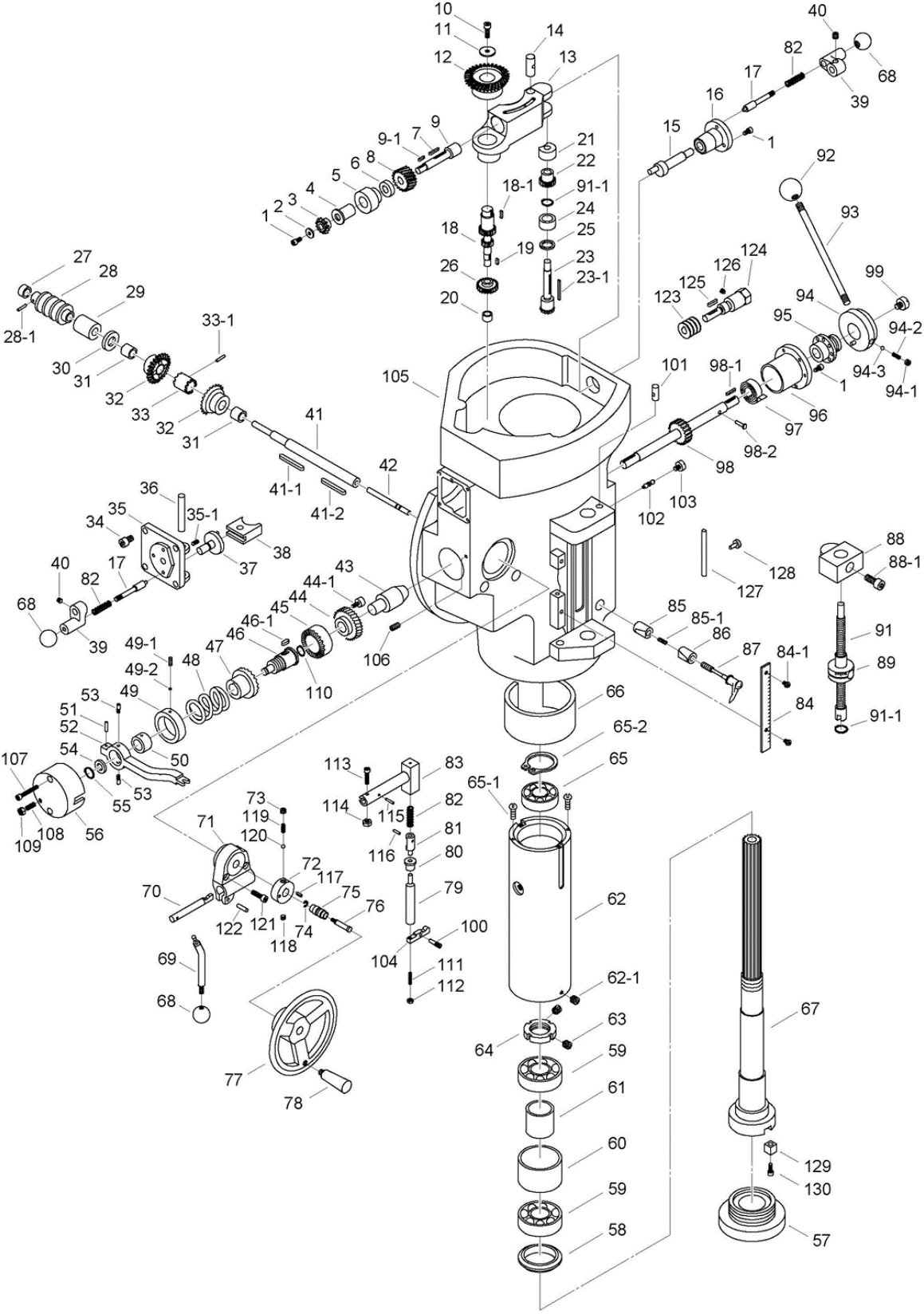

12.3.2 JTM-1254VS Lower Head Assembly – Parts List

Index No	Part No	Description	Size	Qty
1	TS-1502031	Hex Socket Cap Screw	M5x12L	6
2	JTM949EVS-B02	Flat Washer	Ø5	1
3	JTM1254VS-B03	Feed Gear		1
4	JTM1254VS-B04	Shaft Sleeve		1
5	JTM1254VS-B05	Worm Cradle Bushing		1
6	JTM1254VS-B06	Worm Gear Spacer		1
7	KF2R3320	Key	3x3x20L	1
8	JTM1254VS-B08	Feed Drive Worm Gear		1
9	JTM1254VS-B09	Worm Gear Shaft		1
9-1	KEY3310	Worm Shaft Key	3x3x10L	1
10	JTM1254VS-B10	Hex Socket Cap Screw	5/16"x1/2"L	1
11	JTM1254VS-B11	Washer	5/16"	1
12	JTM1254VS-B12	Feed Reverse Bevel Gear		1
13	JTM1254VS-B13	Worm Gear Cradle		1
14	JTM1254VS-B14	Feed Engage Pin		1
15	JTM949EVS-B18	Cam Rod		1
16	JTM949EVS-B19	Shift Sleeve		1
17	JTM949EVS-B20	Lock Rod		2
18	JTM1254VS-B18	Feed Drive Gear		1
	JTM1254VS-B18A	Feed Drive Gear Assembly (includes #18 and 19)		1
18-1	KF2R5508	Key	5x5x8L	1
19	KF2R5512	Key	5x5x12L	1
20	JTM1254VS-B20	Needle Bearing	BA66	1
21	JTM1254VS-B21	Upper Bushing		1
22	JTM1254VS-B22	Cluster Gear		1
23	JTM1254VS-B23	Bevel Gear Shaft		1
23-1	KF2R4445	Key	4x4x45L	1
24	JTM1254VS-B24	Bevel Gear Bushing		1
25	JTM1254VS-B25	Spacer		1
26	JTM1254VS-B26	Feed Drive Gear	TA2620Z	1
27	JTM1254VS-B27	Bushing		1
28	JTM1254VS-B28	Worm		1
28-1	JTM1254VS-B28-1	Spring Pin		1
29	JTM1254VS-B29	Feed Worm Shaft Bushing		1
30	JTM1254VS-B30	Bevel Gear Thrust Spacer		1
31	JTM1254VS-B31	Bushing		2
32	JTM1254VS-B32	Feed Reverse Bevel Gear		2
33	JTM1254VS-B33	Feed Reverse Clutch		1
33-1	JTM1254VS-B33-1	Spring Pin		1
34	TS-1502021	Hex Socket Cap Screw	M5x10L	4
35	JTM949EVS-B66	Cluster Gear Cover		1
35-1	TS-1522031	Socket Set Screw	M5x10L	1
36	JTM949EVS-B60	Feed Shift Rod		1
37	JTM1254VS-B37	Cluster Gear Shift Crank		1
38	JTM1254VS-B38	Feed Gear Shift Fork		1
39	JTM949EVS-B23	Crank		2
40	5302731	Socket Set Screw	M8x6	2
41	JTM1254VS-B41	Feed Worm Shaft		1
41-1	KF2R5515	Key	5x5x15L	1
41-2	JVM836B79-2	Key	5x5x10L	1
42	JTM1254VS-B42	Reverse Clutch Rod		1
43	JTM1254VS-B43	Pinion Shaft		1
44	JTM1254VS-B44	Overload Clutch Worm Gear		1
44-1	JTM1254VS-B44-1	Screw		3
45	JTM1254VS-B45	Overload Clutch Ring		1
46	JTM1254VS-B46	Overload Clutch Sleeve		1
	JTM1254VS-B46A	Overload Clutch Assembly (includes #46,47,49, 49-1,49-2)		1
46-1	KF2R5516	Key	5x5x16L	1
47	JTM1254VS-B47	Overload Clutch		1
48	JTM1254VS-B48	Safety Clutch Spring		1

Index No	Part No	Description	Size	Qty
49	JTM1254VS-B49	Overload Clutch Lockout		1
49-1	TS-2276081	Set Screw	M6x8L	1
49-2	JTM1254VS-B49-2	Lock Block		1
50	JTM1254VS-B50	Clutch Ring		1
51	GA7X-122	Spring Pin	Ø5x20L	1
52	JTM1254VS-B52	Trip Lever		1
53	JTM1254VS-B53	Clutch Ring Pin		2
54	JTM1254VS-B54	Washer		1
55	STW10	Retaining Ring	STW10	1
56	JTM1254VS-B56	Clutch Arm Cover		1
57	JTM1254VS-B57	Nose Piece		1
58	JTM1254VS-B58	Spindle Shield		1
59	BB-7010ZZ	Ball Bearing	7010ZZ	2
60	JTM1254VS-B60	Bearing Spacer (Large)		1
61	JTM1254VS-B61	Bearing Spacer (Small)		1
62	JTM1254VS-B62	Quill		1
62-1	5308081	Set Screw	M5x5L	1
63	TS-1523011	Set Screw	M6x6L	2
64	AN10	Bearing Nut	AN10	1
65	BB-6008ZZ	Ball Bearing	6008ZZ	1
65-1	TS-1533032	Pan Head Cross Screw	M5x10L	2
65-2	2210-255	Retaining Ring	STW40	1
66	JTM1254VS-B66	Quill Skirt		1
67	JTM1254VS-B67	Spindle	NT40	1
68	BH1/4	Black Plastic Ball	1/4"	3
69	JTM949EVS-B104	Trip Handle		1
70	JTM1254VS-B70	Cam Rod		1
71	JTM1254VS-B71	Feed Trip Bracket		1
72	JTM1254VS-B72	Handwheel Clutch		1
73	5302731	Set Screw	M8x6L	1
74	ETW6	Retaining Ring	ETW6	1
75	JTM1254VS-B75	Feed Reverse Stud		1
	JTM1254VS-B75A	Feed Reverse Stud Assembly (includes #74,75,76)		1
76	JTM1254VS-B76	Feed Reverse Bolt		1
77	JTM1254VS-B77	Cast Handwheel		1
77A	JTM1254VS-B77HA	Handwheel Assembly (includes #77,78)		1
78	JTM1254VS-B78	Handle		1
79	JTM1254VS-B79	Feed Trip Plunger		1
80	JTM1254VS-B80	Bushing		1
81	JTM1254VS-B81	Trip Plunger		1
82	JTM949EVS-B21	Spring		3
83	JTM1254VS-B83	Cam Rod Sleeve Assembly		1
84	JTM1254VS-B84	Micrometer Scale		1
84-1	TS-2171012	Pan Head Cross Screw	M4x6L	2
85	JTM1254VS-B85	Quill Lock Sleeve		1
85-1	JTM1254VS-B85-1	Spring		1
86	JTM1254VS-B86	Quill Lock Sleeve		1
87	JTM1254VS-B87	Lock Handle		1
88	JTM1254VS-B88	Quill Stop Block		1
88-1	TS-0209032	Hex Socket Cap Screw	3/8"-24UNFx3/4"	1
89	JTM949EVS-B162	Micrometer Nut		1
91	JTM949EVS-B164	Quill Micro-Screw		1
91-1	STW16	Retaining Ring	STW16	2
92	JTM949EVS-B77	Ball Grip		1
93	JTM949EVS-B84	Handle		1
94	JTM949EVS-B138	Hub		1
94-1	TS-0270031	Set Screw	5/16"x3/8"	1
94-2	JTM1254VS-B94-2	Spring		1
94-3	SB-3/16	Steel Ball	3/16 in.	1
95	JTM1254VS-B95	Hub Sleeve		1
96	JTM1254VS-B96	Spring Cover		1
97	JTM1254VS-B97	Adjustable Spring		1

Index No	Part No	Description	Size	Qty
98	JTM1254VS-B98	Quill Pinion Shaft		1
	JTM1254VS-B98A	Quill Pinion Shaft Assembly (includes #98,98-2)		1
98-1	KF2R5525	Key	5x5x25L	1
98-2	JTM1254VS-B98-2	T type Pin		1
99	JTM1254VS-B99	Pinion Shaft Hub		1
100	JTM1254VS-B100	Trip Lever Pin		1
101	JTM1254VS-B101	Rod		1
102	JTM1254VS-B102	Lever		1
103	JTM1254VS-B103	Screw		1
104	JTM1254VS-B104	Feed Trip Lever		1
105	JTM1254VS-B105	Quill Housing		1
106	TS-1523021	Set Screw	M6x8L	1
107	TS-1502081	Hex Socket Cap Screw	M5x35L	2
108	TS-1523051	Set Screw	M6x16L	1
109	TS-2311061	Hex Nut	M6	1
110	STW22	Retaining Ring	STW22	1
111	TS-1521071	Set Screw	M4x20L	1
112	TS-1540021	Hex Nut	M4	1
113	TS-1502051	Hex Socket Cap Screw	M5x20L	1
114	TS-1540031	Hex Nut	M5	1
115	JTM1254VS-B115	Spring Pin		1
116	5302611	Spring Pin	Ø3x12L	1
117	KF2R3312	Key	3x3x12L	1
118	TS-1523011	Socket Set Screw	M6x6	1
119	JTM1254VS-B119	Spring		1
120	SB-3/16	Steel Ball	3/16 in.	1
121	TS-1503051	Hex Socket Cap Screw	M6x20	2
122	5625391	Spring Pin	Ø5x16L	1
123	JTM1254VS-B123	Worm Gear		1
124	JTM1254VS-B124	Worm Shaft		1
	JTM1254VS-B124A	Worm Shaft Assembly (includes #124,125,126)		1
125	KF2R4418	Key	4x4x18L	1
126	JTM1254VS-B126	Set Screw		1
127	JTM949EVS-B25	Indicator Rod		1
128	JTM949EVS-B26	Indicator Rod Screw		1
129	JTM1254VS-B129	Stop Block		2
130	TS-1504041	Hex Socket Cap Screw	M8x20L	2

12.4.1 JTM-1254RVS (R8) Lower Head Assembly – Exploded View

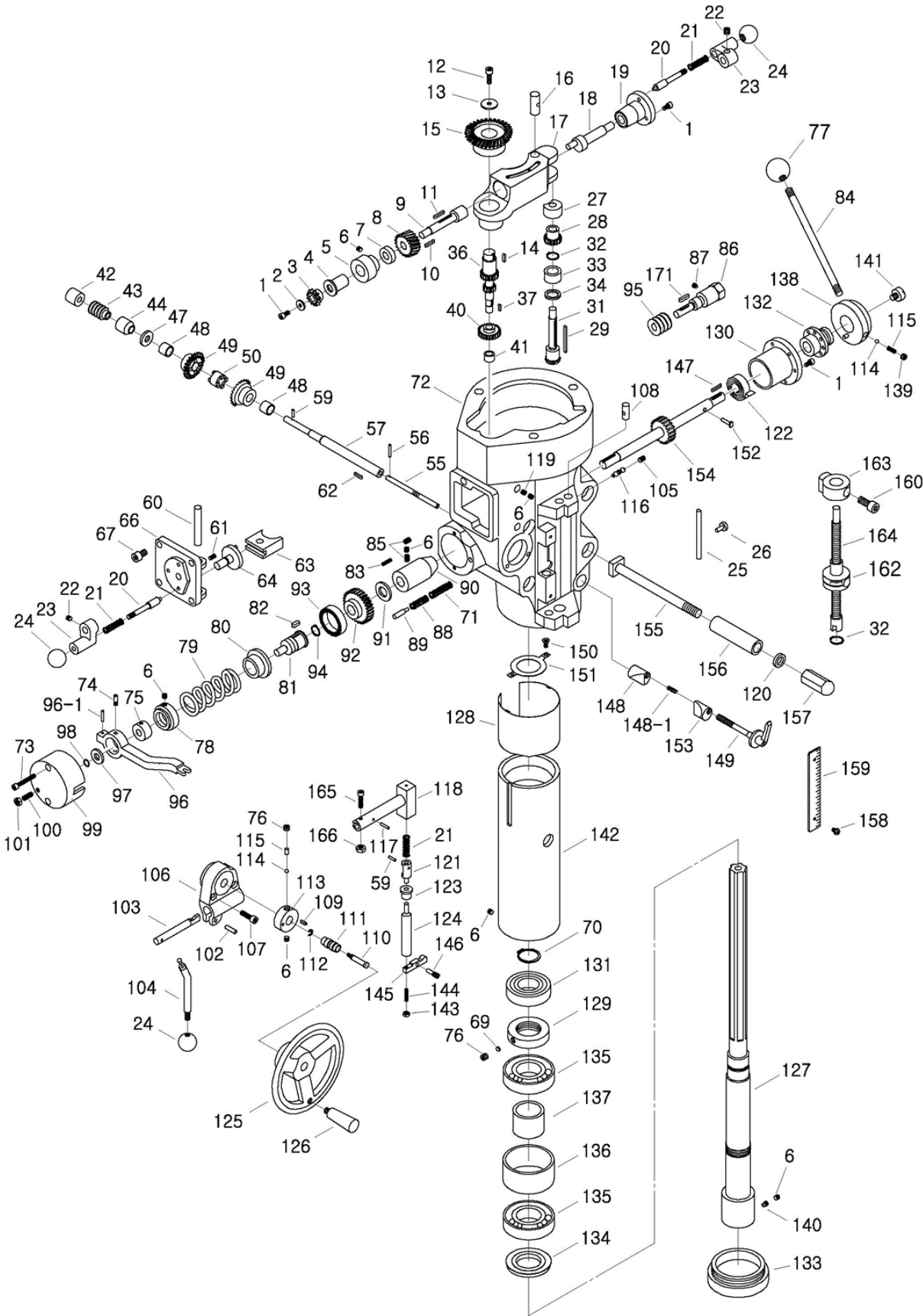

12.4.2 JTM-1254RVS (R8) Lower Head Assembly – Parts List

Index No	Part No	Description	Size	Qty
1	TS-1502031	Hex Socket Cap Screw	M5x12	6
2	JTM949EVS-B02	Flat Washer	Ø5	1
3	JTM949EVS-B03	Feed Gear		1
4	JTM949EVS-B04	Shaft Sleeve		1
5	JTM949EVS-B05	Worm Cradle Bushing		1
6	TS-1523011	Socket Set Screw	M6x6	8
7	JTM949EVS-B07	Worm Gear Spacer		1
8	JTM949EVS-B08	Feed Drive Worm Gear		1
9	JTM949EVS-B09	Worm Gear Shaft		1
10	JTM949EVS-B10	Worm Shaft Key	3x3x8	1
11	KF2R3320	Key	3x3x20	1
12	TS-1503041	Hex Socket Cap Screw	M6x16	1
13	JTM949EVS-B13	Flat Washer	Ø6	1
14	KF2R5508	Key	5x5x8	1
15	JTM949EVS-B15	Feed Reverse Bevel Gear		1
16	JTM949EVS-B16	Feed Engage Pin		1
17	JTM949EVS-B17	Worm Gear Cradle		1
18	JTM949EVS-B18	Cam Rod		1
19	JTM949EVS-B19	Shift Sleeve		1
20	JTM949EVS-B20	Lock Rod		2
21	JTM949EVS-B21	Spring		3
22	5302731	Socket Set Screw	M8x6	2
23	JTM949EVS-B23	Crank		2
24	BH1/4	Black Plastic Ball	1/4"	3
25	JTM949EVS-B25	Indicator Rod		1
26	JTM949EVS-B26	Indicator Rod Screw		1
27	JTM949EVS-B27	Upper Bushing		1
28	JTM949EVS-B28	Cluster Gear		1
29	KF2R4445	Key	4x4x45	1
31	JTM949EVS-B31	Bevel Gear Shaft		1
32	STW16	Retaining Ring	STW16	2
33	JTM949EVS-B33	Bevel Gear Bushing		1
34	JTM949EVS-B34	Spacer		1
36	JTM949EVS-B36	Feed Drive Gear		1
36A	JTM949EVS-B36A	Feed Drive Gear Assembly (#36,37)		1
37	KF2R5512	Key	5x5x12	1
40	JTM949EVS-B40	Feed Drive Gear		1
41	BB-BA66	Needle Bearing	BA66	1
42	JTM949EVS-B42	Bushing		1
43	JTM949EVS-B43	Worm		1
44	JTM949EVS-B44	Feed Worm Shaft Bushing		1
47	JTM949EVS-B47	Bevel Gear Thrust Spacer		1
48	JTM949EVS-B48	Bushing		2
49	JTM949EVS-B49	Feed Reverse Bevel Gear		2
50	JTM949EVS-B50	Feed Reverse Clutch		1
55	JTM949EVS-B55	Reverse Clutch Rod		1
56	TS-209203	Spring Pin	3x20	1
57	JTM949EVS-B57	Feed Worm Shaft		1
59	5302611	Spring Pin	3x12	2
60	JTM949EVS-B60	Feed Shift Rod		1
61	TS-1522031	Socket Set Screw	M5x10	1
62	KF2R3315	Key	3x3x15	1
63	JTM949EVS-B63	Feed Gear Shift Fork		1
64	JTM949EVS-B64	Cluster Gear Shift Crank		1
66	JTM949EVS-B66	Cluster Gear Cover		1
67	TS-1502021	Hex Socket Cap Screw	M5x10	4
69	JTM949EVS-B69	Lock Block		1
70	2210-266	Retaining Ring	STW30	1
71	JTM949EVS-B71	Spring	10x20	1
72	JTM949EVS-B72	Quill Housing	105mm	1

Index No	Part No	Description	Size	Qty
73	TS-1502081	Hex Socket Cap Screw	M5x35	2
74	JTM949EVS-B74	Clutch Ring Pin		2
75	JTM949EVS-B75	Clutch Ring		1
76	5302731	Socket Set Screw	M8x6	2
77	JTM949EVS-B77	Ball Grip		1
78	JTM949EVS-B78	Overload Clutch Lockout		1
79	JTM949EVS-B79	Safety Clutch Spring		1
80	JTM949EVS-B80	Overload Clutch		1
80A	JTM949EVS-B80A	Overload Clutch Assembly (#6,78,80,81)		
81	JTM949EVS-B81	Overload Clutch Sleeve		1
82	KF2R5516	Key	5x5x16	1
83	TS-1532052	Pan Head Machine Screw	M4x16	3
84	JTM949EVS-B84	Handle		1
85	TS-1523031	Socket Set Screw	M6x10	2
86	JTM949EVS-B86	Worm Shaft		1
87	TS-1523011	Set Screw	M6x6	1
88	JTM949EVS-B88	Spring		1
89	JTM949EVS-B89	Spring Plunger		1
90	JTM949EVS-B90	Pinion Shaft		1
91	JTM949EVS-B91	Spacer		1
92	JTM949EVS-B92	Overload Clutch Worm Gear		1
93	JTM949EVS-B93	Overload Clutch Ring		1
94	STW22	Retaining Ring	STW22	1
95	JTM949EVS-B95	Worm Gear		1
96	JTM949EVS-B96	Trip Lever		1
96-1	GA7X-122	Spring Pin	Ø5x20	1
97	JTM949EVS-B97	Washer		1
98	STW10	Retaining Ring	STW10	1
99	JTM949EVS-B99	Clutch Arm Cover		1
100	TS-1523051	Socket Set Screw	M6x16	1
101	TS-2311061	Hex Nut	M6	1
102	5625391	Spring Pin	Ø5x16	1
103	JTM949EVS-B103	Cam Rod		1
104	JTM949EVS-B104	Trip Handle		1
105	5302731	Socket Set Screw	M8x6	1
106	JTM949EVS-B106	Feed Trip Bracket		1
107	TS-1503051	Hex Socket Cap Screw	M6x20	2
108	JTM949EVS-B108	Plunger		1
109	KF2R3312	Key	3x3x12	1
110	JTM949EVS-B110	Feed Reverse Stud Bolt		1
110A	JTM949EVS-B110A	Feed Reverse Stud Assembly (#110,111,112)		
111	JTM949EVS-B111	Feed Reverse Stud		1
112	ETW6	Retaining Ring	ETW6	1
113	JTM949EVS-B113	Handwheel Clutch		1
114	SB-3/16	Steel Ball	3/16"	2
115	JTM949EVS-B115	Spring		2
116	JTM949EVS-B116	Lever		1
117	JTM949EVS-B117	Spring Pin	Ø3x16	1
118	JTM949EVS-B118	Cam Rod Sleeve Assembly		1
119	TS-1523011	Socket Set Screw	M6x6	2
120	JTM949EVS-B120	Flat Washer	Ø13	4
121	JTM949EVS-B121	Trip Plunger		1
122	JTM949EVS-B122	Adjustable Spring		1
123	JTM949EVS-B123	Bushing		1
124	JTM949EVS-B124	Feed Trip Plunger		1
125	JTM1254VS-B77	Cast Handwheel		1
125A	JTM1254VS-B77HA	Handwheel Assembly (#125,126)		
126	JTM1254VS-B78	Handle		1
127	JTM949EVS-B127	Spindle	R8	1
128	JTM949EVS-B128	Quill Skirt		1
129	JTM949EVS-B129	Lock Nut	M35	1
130	JTM949EVS-B130	Spring Cover		1

Index No	Part No	Description	Size	Qty
131	BB-6206ZZ	Ball Bearing	6206ZZ	1
132	JTM949EVS-B132	Hub Sleeve		1
133	JTM949EVS-B133	Nose Piece		1
134	JTM949EVS-B134	Spindle Shield		1
135	BB-7207C	Ball Bearing	7207C	2
136	JTM949EVS-B136	Bearing Spacer (large)		1
136A	JTM949EVS-B136A	Bearing Spacer Assembly (#136,137)		
137	JTM949EVS-B137	Bearing Spacer (small)		1
138	JTM949EVS-B138	Hub		1
139	TS-0270011	Socket Set Screw	5/16"x1/4"	1
140	TS-1523011	Socket Set Screw	M6x6	1
141	JTM949EVS-B141	Pinion Shaft Hub		1
142	JTM949EVS-B142	Quill		1
143	TS-1540021	Hex Nut	M4	1
144	TS-1521071	Socket Set Screw	M4x20	1
145	JTM949EVS-B145	Feed Trip Lever		1
146	JTM949EVS-B146	Trip Lever Pin		1
147	KF2R5525	Key	5x5x25	1
148	JTM949EVS-B148	Quill Lock Sleeve		1
148-1	JTM949EVS-B148-1	Spring		1
149	JTM949EVS-B149	Lock Handle	M8	1
150	TS-1533032	Pan Head Screw	M5x10	2
151	JTM949EVS-B151	Washer		1
152	JTM949EVS-B152	T-type Pin		1
153	JTM949EVS-B153	Quill Lock Sleeve		1
154	JTM949EVS-B154	Quill Pinion Shaft		1
154A	JTM949EVS-B154A	Quill Pinion Shaft Assembly (#152,154)		
155	JTM949EVS-B155	T-Bolt Assembly		4
156	JTM949EVS-B156	Spacer		4
157	JTM949EVS-B157	Lock Nut		4
158	TS-2171012	Pan Head Screw	M4x6	2
159	JTM949EVS-B159	Micrometer Scale		1
160	TS-0209032	Hex Socket Cap Screw	3/8"-24UNFx3/4"	1
162	JTM949EVS-B162	Micrometer Nut	Inch	1
163	JTM949EVS-B163	Quill Stop Knob		1
164	JTM949EVS-B164	Quill Micro-Screw	Inch	1
165	TS-1502051	Hex Socket Cap Screw	M5x20	1
166	TS-1540031	Hex Nut	M5	1
171	KF2R4418	Key	4x4x18	1

12.5.1 JTM-1254VS Base Machine – Exploded View

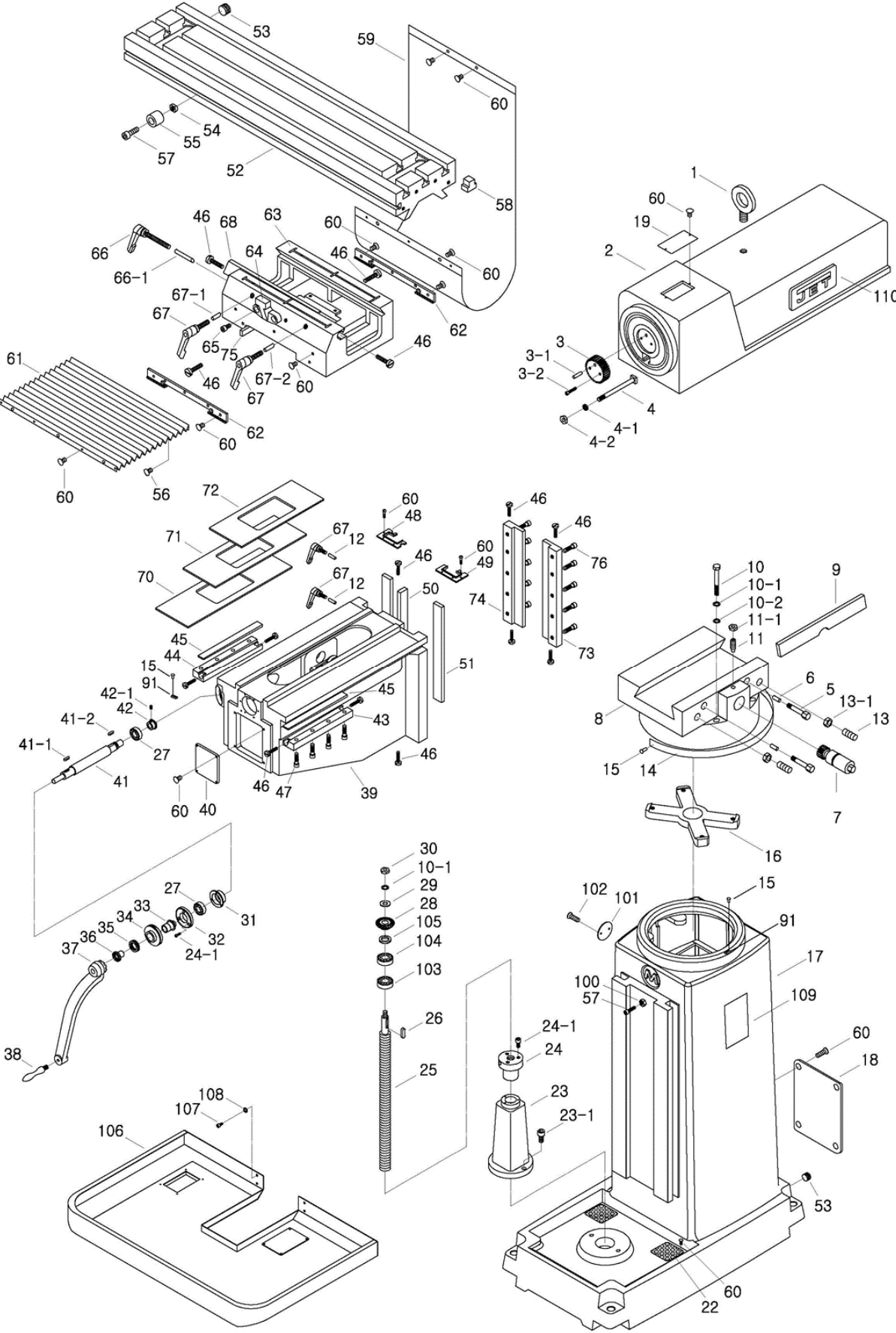

12.5.2 JTM-1254VS Base Machine – Parts List

Index No	Part No	Description	Size	Qty
1	JTM1050EVS-C98	Lifting Ring	M30	1
2	JTM1254VS-C02	Ram		1
3	JTM949EVS-C02	Worm Gear		1
3-1	5501115	Spring Pin	Ø6x30L	1
3-2	TS-1504061	Hex Socket Cap Screw	M8x30L	2
4	JTM1254VS-C04	Bolt	5/8"	4
4-1	TS-2361161	Spring Washer	Ø16	4
4-2	TS-0561071	Hex Nut	5/8"	4
5	JTM1254VS-C05	Ram Lock Bolt		2
6	JTM1254VS-C06	Ram Lock Plunger		2
7	JTM1254VS-C07	Ram Pinion		1
8	JTM1254VS-C08	Turret		1
9	JTM1254VS-C09	Ram/Turret Gib		1
10	JTM1254VS-C10	Hex Head Screw	M12x185L	4
10-1	TS-2361121	Spring Washer	Ø12	5
10-2	JTM949EVS-B120	Flat Washer	Ø13	4
11	JWS35X-222	Socket Set Screw	M8x30L	1
11-1	TS-1540061	Hex Nut	M8	1
12	JTM1254VS-C12	Knee Lock Plunger		2
13	JTM1254VS-C13	Set Screw	M10x60L	2
13-1	TS-2331101	Hex Nut	M10	2
14	JTM1254VS-C14	Turret Scale		1
15	RN2L6	Rivet	Ø2x6L	6
16	JTM1254VS-C16	Spider		1
17	JTM1254VS-C17	Column		1
18	JTM1254VS-C18	Plate		1
19	JTM1254VS-C19	Ram Cover		1
22	JTM1254VS-C22	Strainer Net		2
23	JTM1254VS-C23	Elevating Screw Housing		1
23-1	TS-1505071	Hex Socket Cap Screw	M10x45L	2
24	JTM1254VS-C24	Elevating Nut (Inch)	Ø32 x 5 tpi	1
24-1	TS-1503051	Hex Socket Cap Screw	M6x20L	6
25	JTM1254VS-C25	Lead Screw (Inch)	Ø35 x 5tpi (610L)	1
26	KF2R5520	Key	5x5x20L	1
27	BB-6204ZZ	Bearing	6204ZZ	2
28	JTM949EVS-C58	Bevel Gear	36T	1
29	JTM1254VS-C29	Washer	Ø13xØ32x5t	1
30	JTM1254VS-C30	Hex Nut	1/2-20UNF	1
31	JTM1254VS-C31	Bearing Seat		1
32	JTM1254VS-C32	Cover		1
33	JTM1254VS-C33	Dial Holder		1
34	JTM1254VS-C34	Dial (Inch)	200/0.001"	1
35	JTM1254VS-C35	Dial Lock Nut		1
36	JTM1254VS-C36	Clutch Insert		1
37	JTM1050EVS2-75	Elevating Crank		1
38	JTM949EVS-C62	Handle		1
39	JTM1254VS-C39	Knee		1
40	JTM1254VS-C40	Knee Cover		1
41	JTM1254VS-C41	Elevating Shaft		1
41-1	5308721	Key	3x3x10L	1
41-2	5510498	Key	4x4x16L	1
42	JTM949EVS-C74	Bevel Gear	18T	1
42-1	TS-1523031	Socket Set Screw	M6x10L	1
43	JTM1254VS-C43	Support Plate-R		1
44	JTM1254VS-C44	Support Plate-L		1
45	JTM1254VS-C45	Gib		2
46	JTM1254VS-C46	Adjusting Screw		14
47	TS-1506041	Hex Socket Cap Screw	M12x35L	8
48	JTM1254VS-C48	Knee Wiper (left)		1

Index No	Part No	Description	Size	Qty
49	JTM1254VS-C49	Knee Wiper (right)		1
50	JTM1254VS-C50	Knee/ Column Gib		1
51	JTM1254VS-C51	Knee/ Column Gib		2
52	JTM1254VS-C52	Table	12"x54"	1
53	JTM1254VS-C53	Oil Plug	1/2"PT	3
54	JTM1254VS-C54	Nut		2
55	JTM1254VS-C55	Bushing		2
57	TS-1505041	Hex Socket Cap Screw	M10x30L	3
58	JTM1254VS-C58	T-Rubber		6
59	JTM1254VS-C59	Flat Way Cover (Rear)		1
60	TS-2245102	Socket Head Button Screw	M5x10L	39
61	JTM1254VS-C61	Pleated Way Cover (Front)		1
62	JTM1254VS-C62	Wiper		2
63	JTM1254VS-C63	Saddle		1
64	JTM1254VS-C64	Table Stop Bracket		1
65	TS-1505011	Hex Socket Cap Screw	M10X16L	2
66	JTM1254VS-C66	Lock Handle		1
66-1	JTM1254VS-C66-1	Saddle Lock Plunger		1
67	JTM1254VS-C67	Lock Handle	M12x25L	4
67-1	JTM1254VS-C67-1	Table Lock Plunger 1		1
67-2	JTM1254VS-C67-2	Table Lock Plunger 2		1
68	JTM1254VS-C68	Gib		1
70	JTM949EVS-C48	Chip Guard (Bottom)	580 mm (129x2.0T)	1
71	JTM949EVS-C49	Chip Guard (Middle)	470 mm (129x2.0T)	1
72	JTM949EVS-C41	Chip Guard (Top)	360 mm (129x2.0T)	1
73	JTM1254VS-C73	Knee Support Plate (Right)		1
74	JTM1254VS-C74	Knee Support Plate (Left)		1
75	JTM1254VS-C75	Gib		1
76	F005475	Hex Socket Cap Screw	M14x35L	10
91	JTM1254VS-C91	Pointer		2
100	TS-1540071	Hex Nut	M10	1
101	JTM949EVS-C84	Side Cover		1
102	TS-1503031	Socket Head Button Screw	M6x12L	2
103	BB-51305	Bearing	51305	1
104	BB-6205ZZ	Ball Bearing	6205ZZ	1
105	JTM949EVS-C44	Washer		1
106	JTM1254VS-C106	Chip Pan		1
107	TS-1504031	Hex Socket Cap Screw	M6x12L	4
108	TS-1550041	Flat Washer	Ø6	4
109	LM000183	ID/Warning Label, JTM-1254VS		1
110	JET-254	JET Logo	254x105 mm	2
	JTM1254VS-TB	Tool Box Kit Complete (not shown)		1

12.6.1 JTM-1254RVS (R8) Base Machine – Exploded View

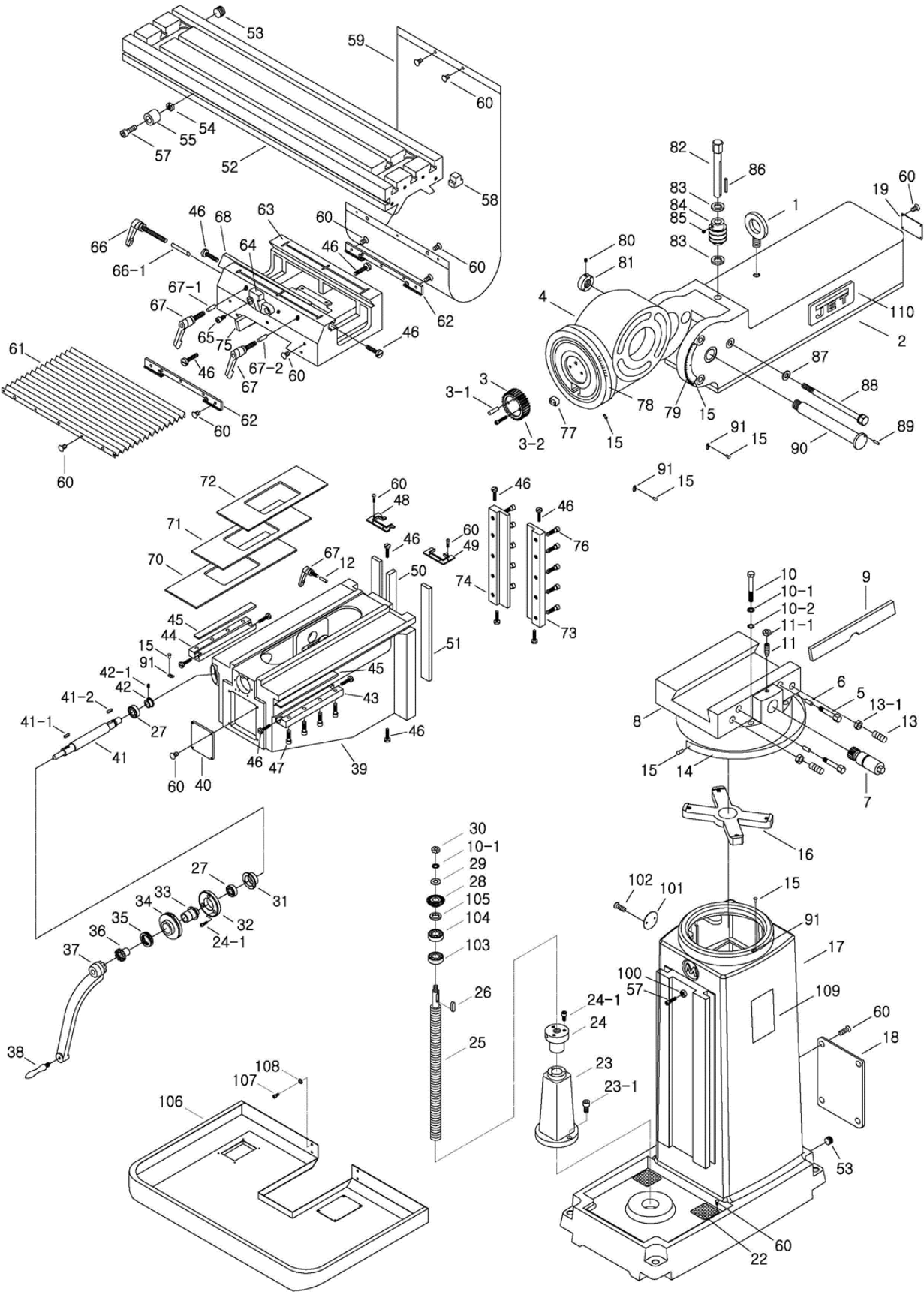

12.6.2 JTM-1254RVS (R8) Base Machine – Parts List

Index No	Part No	Description	Size	Qty
1	JTM1050EVS2-C29A	Lifting Ring	M20	1
2	JTM1050EVS2-30	Ram		1
3	JTM949EVS-C02	Worm Gear		1
3-1	JTM949EVS-C03-1	Spring Pin	Ø6x30L	1
3-2	TS-1504061	Hex Socket Cap Screw	M8x30L	2
4	JTM1050EVS2-C40	Ram Adapter	Ø30	1
5	JTM1254VS-C05	Ram Lock Bolt		2
6	JTM1254VS-C06	Ram Lock Plunger		2
7	JTM1050EVS2-88	Ram Pinion	M2.54x13T	1
8	JTM1254VS-C08	Turret		1
9	JTM1050EVS2-79	Turret Gib	7.6t	1
10	JTM1254RVS-C10	Hex Head Screw	M12x125L	4
10-1	TS-2361121	Spring Washer	Ø12	5
10-2	JTM949EVS-B120	Flat Washer	Ø13	4
11	JWS35X-222	Socket Set Screw	M8x30L	1
11-1	JTM1254VS-C11-1	Hex Nut	M8	1
12	JTM1254RVS-C12	Knee Lock Plunger	Ø10x35L	2
13	JTM1254RVS-C13	Set Screw	M10x60L	2
13-1	TS-2331101	Hex Nut	M10	2
14	JTM949EVS-C81	Turret Scale		1
15	RN2L6	Rivet	Ø2x6L	12
16	JTM949EVS-C27	Spider		1
17	JTM1254VS-C17	Column		1
18	JTM1254VS-C18	Plate		1
19	JTM1254VS-C19	Ram Cover		1
22	JTM949EVS-C87	Strainer Net	90*90	2
23	JTM1254VS-C23	Elevating Screw Housing		1
23-1	JTM1254VS-C23-1	Hex Socket Cap Screw	M10x45L	2
24	JTM1254VS-C24	Elevating Nut (Inch)	Ø32 x 5 Tpi	1
24-1	TS-1503051	Hex Socket Cap Screw	M6x20L	6
25	JTM1254VS-C25	Lead Screw (Inch)	Ø35x5 Tpi (590)	1
26	KF2R5520	Key	5x5x20L	1
27	BB6204ZZ	Bearing	6204ZZ	2
28	JTM1254VS-C28	Bevel Gear	Ø25x36T- 20.6m	1
29	JTM1254VS-C29	Washer	Ø13xØ32x5T	1
30	JTM1254VS-C30	Hex Nut	1/2-20UNF	1
31	JTM1254VS-C31	Bearing Seat		1
32	JTM1254VS-C32	Cover	62mm	1
33	JTM949EVS-C67	Dial Holder	3/4, 51L	1
34	JTM949EVS-C66	Dial (Inch)	100/ 0.001"	1
35	JTM949EVS-C65	Dial Lock Nut		1
36	JTM949EVS-C64	Clutch Insert	3mm, 9T	1
37	JTM1050EVS2-75	Elevating Crank		1
38	JTM949EVS-C62	Handle		1
39	JTM1254VS-C39	Knee		1
40	JTM1254VS-C40	Knee Cover		1
41	JTM1254VS-C41	Elevating Shaft	Ø23.81x354x 538L	1
41-1	JTM1254VS-C41-1	Key	3x3x10L	1
41-2	JTM1254VS-C41-2	Key	4x4x16L	1
42	JTM949EVS-C74	Bevel Gear	18T	1
42-1	TS-1523031	Socket Set Screw	M6x10L	1
43	JTM1254VS-C43	Support Plate-R		1
44	JTM1254VS-C44	Support Plate-L		1
45	JTM1254VS-C45	Gib		2
46	JTM949EVS-C34	Adjustable Screw	M8*37L	14
47	JTM1254VS-C47	Hex Socket Cap Screw	M12x35L	8
48	JTM1254VS-C48	Knee Wiper (Left)		1
49	JTM1254VS-C49	Knee Wiper (Right)		1
50	JTM1254VS-C50	Knee/ Column Gib		1
51	JTM1254VS-C51	Knee/ Column Gib		2

Index No	Part No	Description	Size	Qty
52	JTM1254VS-C52	Table	12"x54"	1
53	JTM1254VS-C53	Oil Plug	1/2"PT	3
54	JTM1254VS-C54	Nut		2
55	JTM1254VS-C55	Bushing		2
57	TS-1505041	Hex Socket Cap Screw	M10x30L	3
58	JTM1254VS-C58	Rubber	23x32x16	6
59	JTM1254VS-C59	Flat Way Cover (rear)	450x850x1.5T	1
60	TS-2245102	Socket Head Button Screw	M5x10L	39
61	JTM1254VS-C61	Pleated Way Cover (front)	450x600L	1
62	JTM1254VS-C62	Wiper		2
63	JTM1254VS-C63	Saddle		1
64	JTM1254VS-C64	Table Stop Bracket		1
65	JTM1254VS-C65	Hex Socket Cap Screw	M10X16L	2
66	JTM949EVS-C21	Lock Handle	M12x25L	1
66-1	JTM1254VS-C66-1	Pluger	Ø10x195L	1
67	JTM949EVS-C21	Lock Handle	M12x25L	4
67-1	JTM1254VS-C67-1	Pluger	Ø10 x L50°	1
67-2	JTM1254VS-C67-2	Pluger	Ø10 x L50°	1
68	JTM1254VS-C68	Gib		1
70	JTM949EVS-C48	Chip Guard (Bottom)	580 mm (129x2.0T)	1
71	JTM949EVS-C49	Chip Guard (Middle)	470 mm (129x2.0T)	2
72	JTM949EVS-C41	Chip Guard (Top)	360 mm (129x2.0T)	1
73	JTM1254VS-C73	Knee Support Plate (Right)		1
74	JTM1254VS-C74	Knee Support Plate (Left)		1
75	JTM1254VS-C75	Gib		1
76	JTM1254VS-C76	Hex Socket Cap Screw	M14x35L	10
77	JTM1254RVS-C77	Lock Stud		1
78	JTM949EVS-C06	Adapter Scale		1
79	JTM949EVS-C12	Angle Scale		1
80	TS-1521021	Set Screw	M4x8L	1
81	JTM1050EVS2-39	Lock Nut	Ø45x13L	1
82	JTM1050EVS2-24	Shaft	19H x162L	1
83	JTM1050EVS2-25	Washer	Ø32*17.6*3.2L	2
84	JTM949EVS-C07	Worm	Ø44.4*17.4*50.7 L	1
85	TS-1523021	Socket Set Screw	M6x8L	1
86	KF2R5549	Key	5x5x50L	1
87	JTM1050EVS2-31	Washer	Ø12	3
88	JTM1050EVS2-32	Adapter Locking Bolt	19H*203L, M14*P2.0	3
89	6293347	Spring Pin	Ø3x16L	1
90	JTM1050EVS2-34	Adapter Shaft	Ø30x200L	1
91	JTM1254RVS-C91	Pointer		4
100	TS-1540071	Hex Nut	M10	1
101	JTM949EVS-C84	Side Cover		1
102	TS-1503031	Socket Head Button Screw	M6x12L	2
103	BA51305	Bearing	51305	1
104	BB6205ZZ	Ball Bearing	6205ZZ	1
105	JTM949EVS-C44	Washer		1
106	JTM1254RVS-C106	Chip Pan	5J	1
107	TS-1504031	Hex Socket Cap Screw	M6x12L	4
108	TS-1550041	Flat Washer	Ø6	4
109	LM000243	ID/Warning Label, JTM-1254RVS		1
110	JET-254	JET Logo	254x105 mm	2
	JTM1254RVS-TB	Tool Box Kit Complete (not shown)		1

12.7.1 JTM-1254VS/RVS Table Assembly – Exploded View

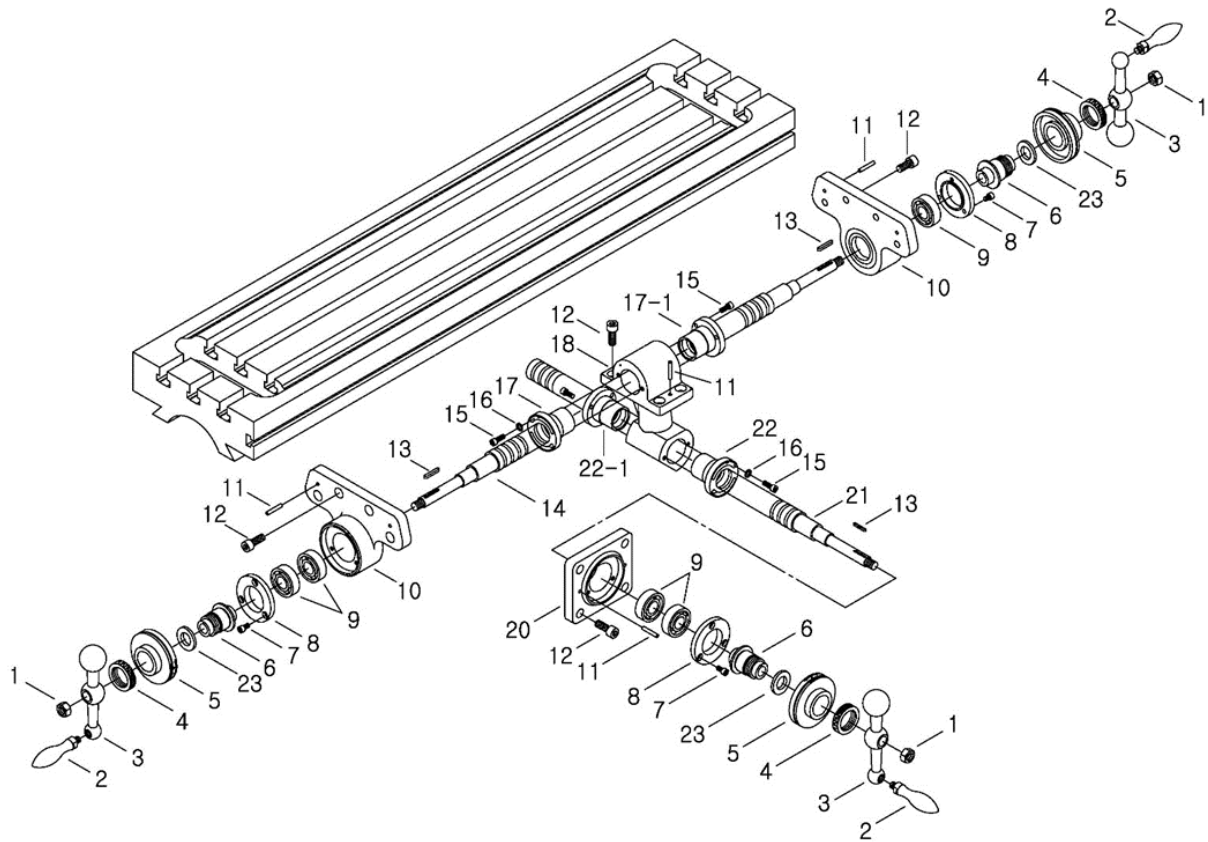

12.7.2 JTM-1254VS/RVS Table Assembly – Parts List

Index No	Part No	Description	Size	Qty
1	TS-0561052	Nut	1/2-20UNF	3
2	JTM949EVS-D02	Handle	3/8"	3
	JTM949EVS-D03A	Ball Crank Assembly (includes #2,3)		1
3	JTM949EVS-D03	Ball Crank		3
4	JTM949EVS-D04	Dial Lock Nut		3
5	JTM949EVS-D05	Dial (Inch)	200/0.001"	3
6	JTM949EVS-D06	Dial Holder	3mm / 56.6L	3
7	TS-1503031	Hex Socket Cap Screw	M6x12	9
8	JTM949EVS-D08	Cover		3
9	BB-6204ZZ	Ball Bearing	6204ZZ	5
10	JTM949EVS-D10	Bearing Bracket	Ø60	2
11	5311251	Spring Pin	Ø5x30	6
12	TS-1505011	Hex Socket Cap Screw	M10x16	16
13	KF2R3325	Key	3x3x25	3
14	JTM1254VS-D14	Lead Screw	Ø32 x 5 tpi (1632)	1
15	TS-1503041	Hex Socket Cap Screw	M6x16	10
16	TS-1550041	Flat Washer	M6	4
17	JTM949EVS-D17	Feed Screw Nut (Inch)	Ø32 x 5 tpi	1
17-1	JTM949EVS-D17-1	Feed Screw Nut (Adjust-I)	Ø32 x 5 tpi	1
18	JTM1254VS-D18	Lead Screw Housing		1
20	JTM949EVS-D20	Cross Bearing Bracket		1
21	JTM1254VS-D21	Cross Feed Screw	Ø32 x 5 tpi (740)	1
22	JTM949EVS-D22	Cross Feed Adjustment Nut (Inch)	Ø32 x 5 TPI	1
22-1	JTM949EVS-D22-1	Cross Feed Nut (Inch)	Ø32 x 5 TPI	1
23	JTM949EVS-D23	Adjusting Washer	Ø45xØ34x0.15t	3

12.8.1 JTM-1254VS/RVS Control Box Assembly – Exploded View

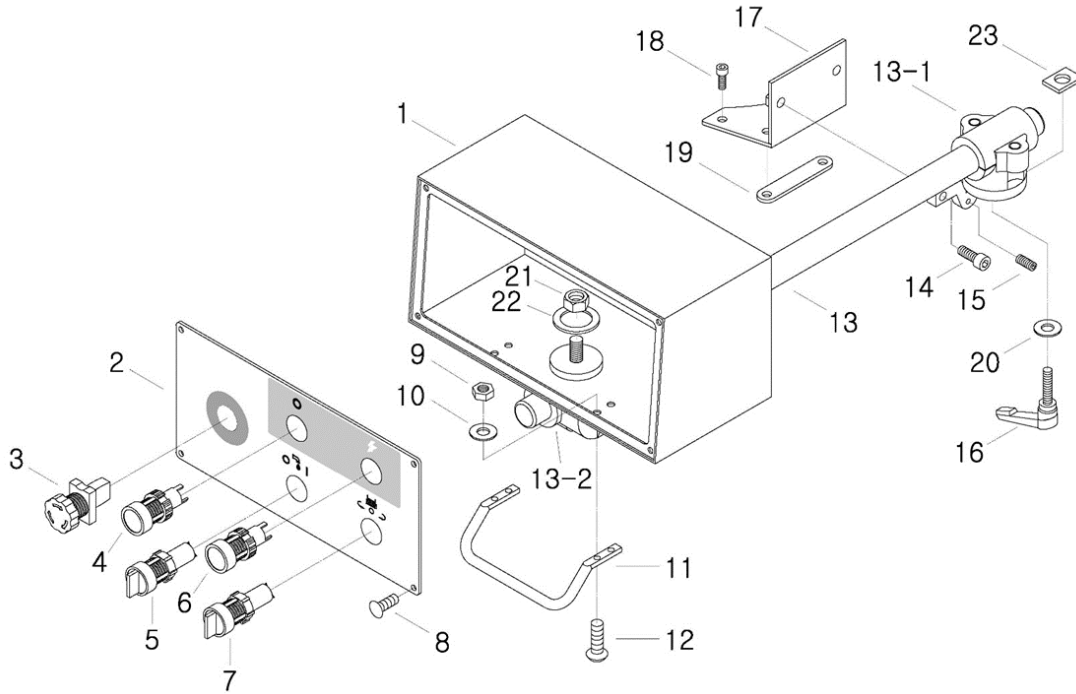

12.8.2 JTM-1254VS/RVS Control Box Assembly – Parts List

Index No	Part No	Description	Size	Qty
	JTM1254VS-CBA	Control Box Assembly (includes #1-8)		1
1	JTM949EVS-E01	Control Box		1
2	JTM1254VS-CB	Control Panel		1
3	JTM949EVS-E09	Emergency Switch		1
4	JTM949EVS-E07	Spindle Stop Button		1
5	JTM949EVS-E06	Coolant Pump Switch		1
6	JTM949EVS-E08	Power Start Button		1
7	JTM949EVS-E04	F/R Select Switch		1
8	TS-2245102	Socket Head Button Screw	M5x10L	4
9	TS-1540031	Hex Nut	M5	4
10	TS-1550031	Flat Washer	Ø5	4
11	JTM949EVS-E12	Handle		1
12	TS-2245162	Socket Head Button Screw	M5x16	4
	JTM949EVS-E14	Support Rod Unit Assembly (includes #13, 13-1, 13-2, 16, 20, 23)		1
13	JTM1254VS-E13	Rod		1
13-1	JTM1254VS-E13-1	Rotating Bracket		1
13-2	JTM1254VS-E13-2	Control Box Bracket		1
14	TS-1504041	Hex Socket Cap Screw	M8X20L	2
15	TS-1523031	Socket Set Screw	M6x10	3
16	JTM949EVS-E18	Lock Handle	M12X35L	1
17	JTM949EVS-E19	Bracket		1
18	TS-1523051	Hex Socket Cap Screw	M6x16L	3
19	JTM1254VS-E19	Spacer		1
20	JTM949EVS-B120	Flat Washer	Ø13xØ20x2T	1
21	TS-0640081	Hex Nylon Lock Nut	5/16"-18	1
22	JTM1254VS-E22	Rubber gasket		1
23	JTM1254VS-E23	Nut		1
	JTM1254VS-D19	Cable (Control Panel to Electrical Box) – not shown		1

12.9.1 JTM-1254VS/RVS Electrical Box – Exploded View

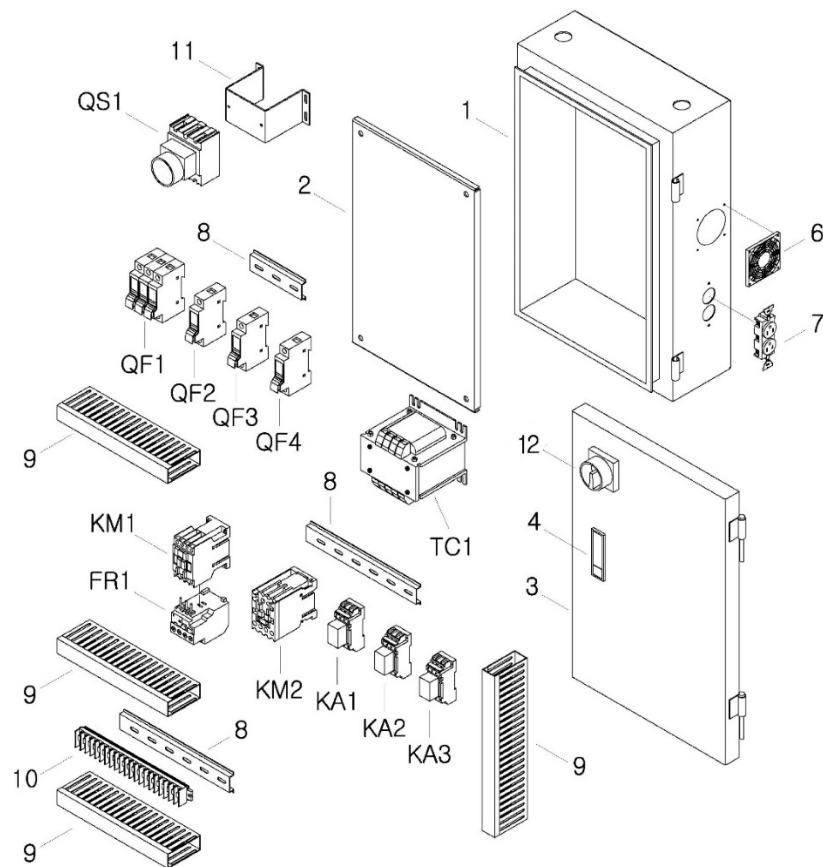

12.9.2 JTM-1254VS/RVS Electrical Box – Parts List

Index No	Part No	Description	Size	Qty
1	JTM949EVS-F01	Electrical Cabinet (RE: JTM949EVS-F21)		1
2	JTM949EVS-F02	Electrical Plate (RE: JTM949EVS-F21)		1
3	JTM949EVS-F03	Electrical Cabinet Door (RE: JTM949EVS-F21)		1
	JTM949EVS-F21	Electrical Cabinet Assembly (includes #1-3)		1
4	JTM949EVS-F04	Door Latch		1
6	JTM949EVS-F18	Fan Cover		1
7	JTM949EVS-F19	Electric Receptacle		1
8	JTM949EVS-F16	Aluminum Rail		2
9	JTM949EVS-F14	Wire Casing		5
10	JTM949EVS-F15	Terminal Block		1
11	JTM949EVS-F21	Switch Bracket		1
12	JTM949EVS-F05-1	Switch Interface		1
QS1	JTM949EVS-F05	Door Switch (includes #12)		1
TC1	JTM949EVS-F06	Transformer	400VA	1
KM1	JTM1254VS-FKM1	Magnetic Contactor	TECO / CU-11	1
FR1	JTM1254VS-FFR1	Flicker Relay		1
KM2	JTM1254VS-FKM2	Magnetic Contactor	TECO / CU-11	1
KA1	JTM1254VS-FKA1	Relay	RMIA4524VAC	1
KA2	JTM1254VS-FKA2	Relay	RMIA21024VAC	1
KA3	JTM1254VS-FKA3	Relay	RMIA4524VAC	1
QF1	JTM1254VS-FQF1	Power Circuit Breaker	3P 25A	1
QF2	JTM1254VS-FQF2	Power Circuit Breaker	1P 2A	1
QF3	JTM1254VS-FQF3	Power Circuit Breaker	1P 6A	1
QF4	JTM1254VS-FQF4	Power Circuit Breaker	1P 6A	1

12.10.1 JTM-1254VS/RVS Coolant Pump (Optional) – Exploded View

12.11.1 JTM-1254VS/RVS Work Lamp – Exploded View

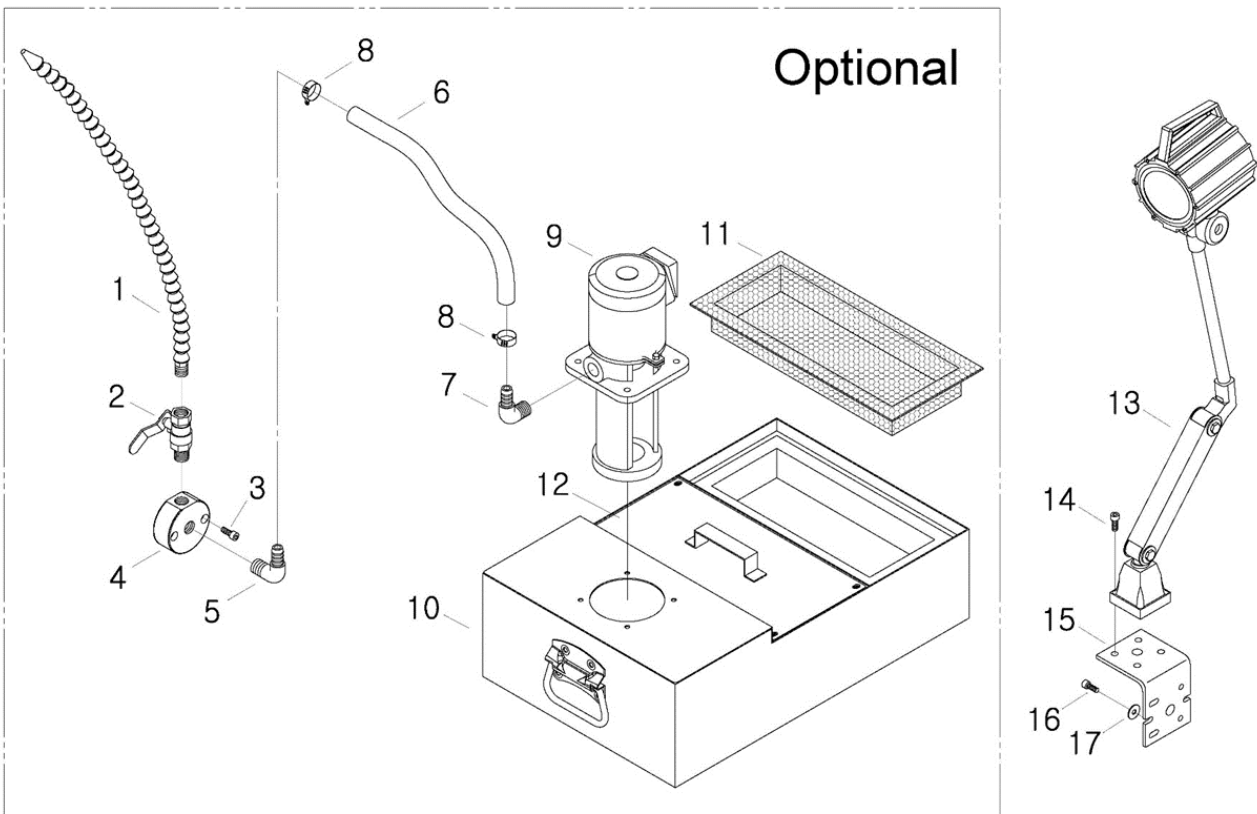

12.10.2 JTM-1254VS/RVS Coolant Pump (Optional) – Parts List

Index No	Part No	Description	Size	Qty
.....	JTM949EVS-G00	Coolant Pump Kit (includes #1 thru 12)
1	JTM949EVS-G01	Plastic Nozzle	1
2	JTM949EVS-G02	Valve	PT 3/8" x 1/2"	1
3	TS-1503091	Hex Socket Cap Screw	M6 x 40	2
4	JTM949EVS-G04	Block	1
5	JTM949EVS-G07	Hose Fitting	PT 3/8" x 1/2" (90°)	1
6	JTM949EVS-G06	Hose	1/2"	1
7	JTM949EVS-G07	Hose Fitting	PT 3/8" x 1/2" (90°)	1
8	JTM949EVS-G08	Hose Clamp	5/6" (11 ~ 20)	2
9	JTM949EVS-G09	Coolant Pump	1/8HP	1
10	JTM949EVS-G10	External Coolant Tank	1
11	JTM949EVS-G11	Strainer	1
12	JTM949EVS-G12	Cover with handle	1

12.11.2 JTM-1254VS/RVS Work Lamp – Parts List

13	JTM949EVS-G13	Work Lamp	24V / LED	1
14	TS-1502041	Hex Socket Cap Screw	M5X16	4
15	JTM949EVS-G15	Work Light Bracket	1
16	TS-1503041	Hex Socket Cap Screw	M6X16	6
17	TS-1550041	Flat Washer	Ø6mm	6
18	JTM949EVS-G18	LED Bulb (not shown)	24V	1

12.12.1 JTM-1254VS/RVS Spindle Guard Assembly – Exploded View

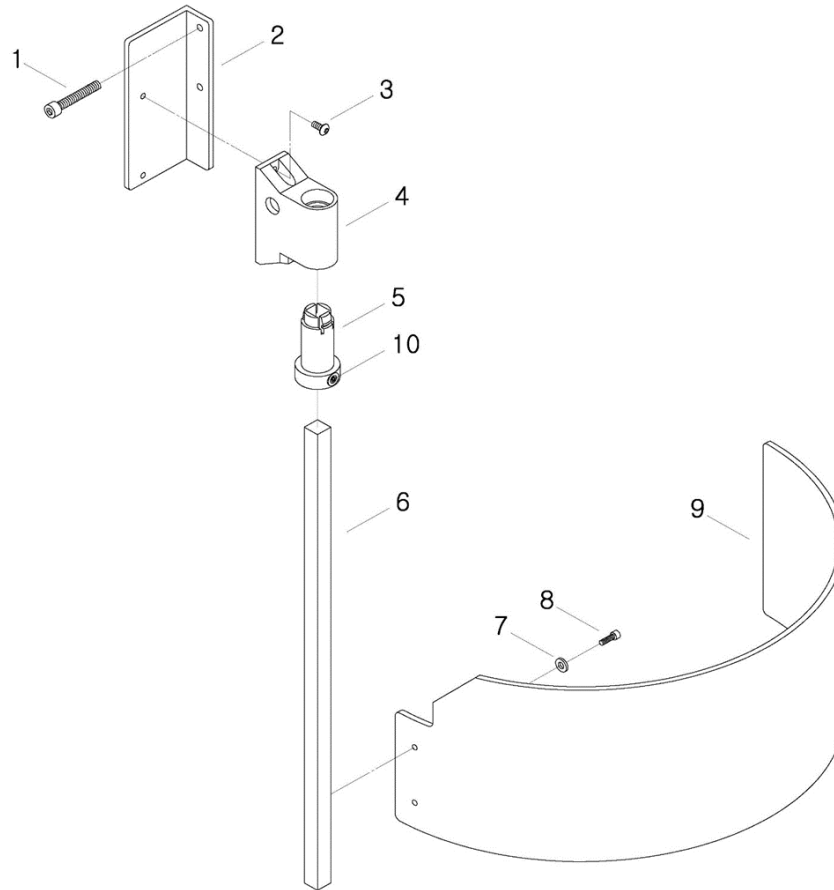

12.12.2 JTM-1254VS/RVS Spindle Guard Assembly – Parts List

Index No	Part No	Description	Size	Qty
	JTM949EVS-SGA	Spindle Guard Assembly (#1 thru 10)		
1	TS-1502101	Hex Socket Cap Screw	M5x45	2
2	JTM949EVS-H02	Support Plate		1
3	TS-2245102	Socket Head Button Screw	M5x10	2
4	JTM949EVS-H04	Bushing Bracket (Re: JTM949EVS-H04A)		1
	JTM949EVS-H04A	Bushing Bracket Assembly (includes #4,5)		1
5	JTM949EVS-H05	Bushing		1
6	JTM949EVS-H06	Support Rod		1
7	TS-1550031	Washer	Ø5	2
8	TS-1502031	Hex Socket Cap Screw	M5x12	2
9	JTM949EVS-H09	Spindle Guard		1
10	TS-1522021	Socket Set Screw	M5x8	1

12.13.1 JTM-1254VS/RVS Lubrication System – Exploded View

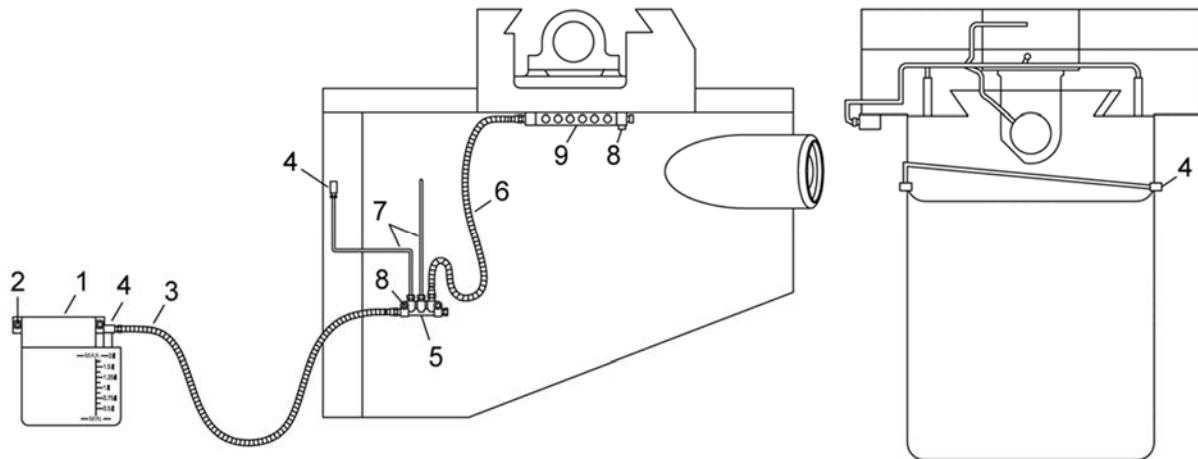

12.13.2 JTM-1254VS/RVS Lubrication System – Parts List

Index No	Part No	Description	Size	Qty
1	JTM949EVS-J01N	Automatic Oiler	2L, 0~180min	1
2	TS-1503061	Hex Socket Cap Screw	M6x25L	2
3	JTM949EVS-J03	Flexible Steel Tube	Ø4	1
4	JTM949EVS-J04	Elbow Adaptor	Ø4	3
5	JTM949EVS-J10	Oil Distributor	Ø4, 6 holes	2
6	JTM949EVS-J06	Flexible Steel Tube		1
7	JTM949EVS-J07	Aluminum Pipe	Ø4	2
8	TS-1502061	Hex Socket Cap Screw	M5x25L	4
9	JTM1254VS-J09	Oil Distributor	Ø4, 8 holes	1
	JTM1254VS-J05A	Oil Distributor Kit (incl. #3,5,6,9)		1

13.0 Electrical Connections – JTM-1254VS/RVS

230V Wiring Diagram

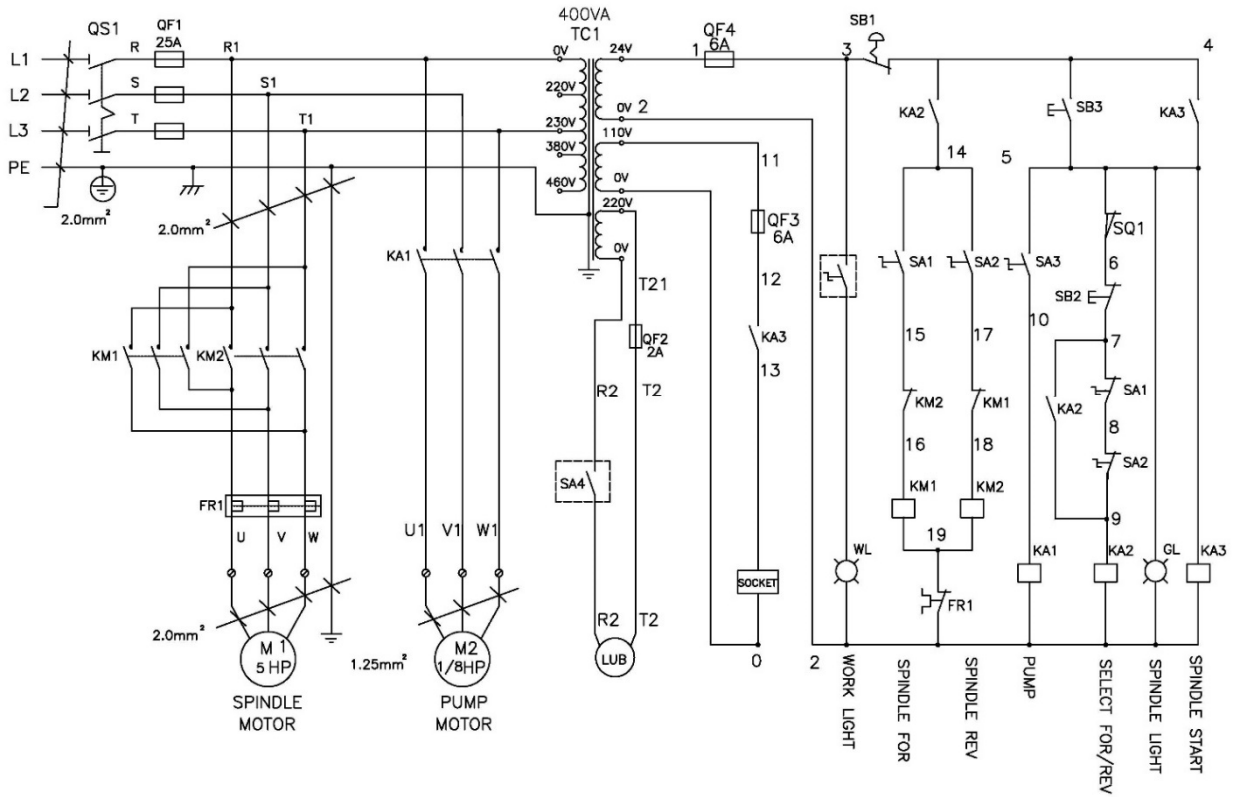

460V Wiring Diagram

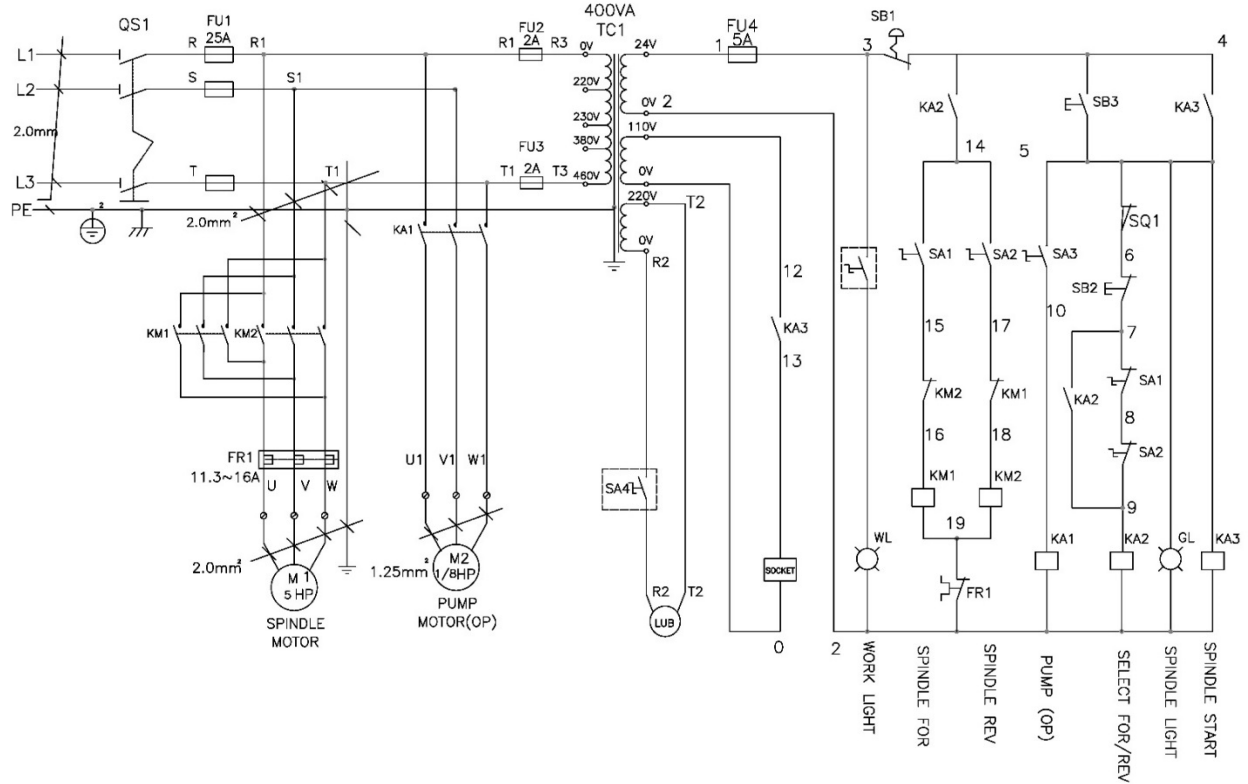

14.0 Warranty and service

JET warrants every product it sells against manufacturers' defects. If one of our tools needs service or repair, please contact Technical Service by calling 1-800-274-6846, 8AM to 5PM CST, Monday through Friday.

Warranty Period

The general warranty lasts for the time period specified in the literature included with your product or on the official JET branded website.

- JET products carry a limited warranty which varies in duration based upon the product. (See chart below)
- Accessories carry a limited warranty of one year from the date of receipt.
- Consumable items are defined as expendable parts or accessories expected to become inoperable within a reasonable amount of use and are covered by a 90 day limited warranty against manufacturer's defects.

Who is Covered

This warranty covers only the initial purchaser of the product from the date of delivery.

What is Covered

This warranty covers any defects in workmanship or materials subject to the limitations stated below. This warranty does not cover failures due directly or indirectly to misuse, abuse, negligence or accidents, normal wear-and-tear, improper repair, alterations or lack of maintenance. JET woodworking machinery is designed to be used with Wood. Use of these machines in the processing of metal, plastics, or other materials outside recommended guidelines may void the warranty. The exceptions are acrylics and other natural items that are made specifically for wood turning.

Warranty Limitations

Woodworking products with a Five Year Warranty that are used for commercial or industrial purposes default to a Two Year Warranty. Please contact Technical Service at 1-800-274-6846 for further clarification.

How to Get Technical Support

Please contact Technical Service by calling 1-800-274-6846. **Please note that you will be asked to provide proof of initial purchase when calling.** If a product requires further inspection, the Technical Service representative will explain and assist with any additional action needed. JET has Authorized Service Centers located throughout the United States. For the name of an Authorized Service Center in your area call 1-800-274-6846 or use the Service Center Locator on the JET website.

More Information

JET is constantly adding new products. For complete, up-to-date product information, check with your local distributor or visit the JET website.

How State Law Applies

This warranty gives you specific legal rights, subject to applicable state law.

Limitations on This Warranty

JET LIMITS ALL IMPLIED WARRANTIES TO THE PERIOD OF THE LIMITED WARRANTY FOR EACH PRODUCT. EXCEPT AS STATED HEREIN, ANY IMPLIED WARRANTIES OF MERCHANTABILITY AND FITNESS FOR A PARTICULAR PURPOSE ARE EXCLUDED. SOME STATES DO NOT ALLOW LIMITATIONS ON HOW LONG AN IMPLIED WARRANTY LASTS, SO THE ABOVE LIMITATION MAY NOT APPLY TO YOU.

JET SHALL IN NO EVENT BE LIABLE FOR DEATH, INJURIES TO PERSONS OR PROPERTY, OR FOR INCIDENTAL, CONTINGENT, SPECIAL, OR CONSEQUENTIAL DAMAGES ARISING FROM THE USE OF OUR PRODUCTS. SOME STATES DO NOT ALLOW THE EXCLUSION OR LIMITATION OF INCIDENTAL OR CONSEQUENTIAL DAMAGES, SO THE ABOVE LIMITATION OR EXCLUSION MAY NOT APPLY TO YOU.

JET sells through distributors only. The specifications listed in JET printed materials and on official JET website are given as general information and are not binding. JET reserves the right to effect at any time, without prior notice, those alterations to parts, fittings, and accessory equipment which they may deem necessary for any reason whatsoever. JET® branded products are not sold in Canada by JPW Industries, Inc.

Product Listing with Warranty Period

90 Days – Parts; Consumable items
1 Year – Motors; Machine Accessories
2 Year – Metalworking Machinery; Electric Hoists, Electric Hoist Accessories; Woodworking Machinery used for industrial or commercial purposes
5 Year – Woodworking Machinery
Limited Lifetime – JET Parallel clamps; VOLT Series Electric Hoists; Manual Hoists; Manual Hoist Accessories; Shop Tools; Warehouse & Dock products; Hand Tools; Air Tools

NOTE: JET is a division of JPW Industries, Inc. References in this document to JET also apply to JPW Industries, Inc., or any of its successors in interest to the JET brand.



427 New Sanford Road
LaVergne, Tennessee 37086
Phone: 800-274-6848
www.jettools.com