

ENC 250™ SINGLE SECTION

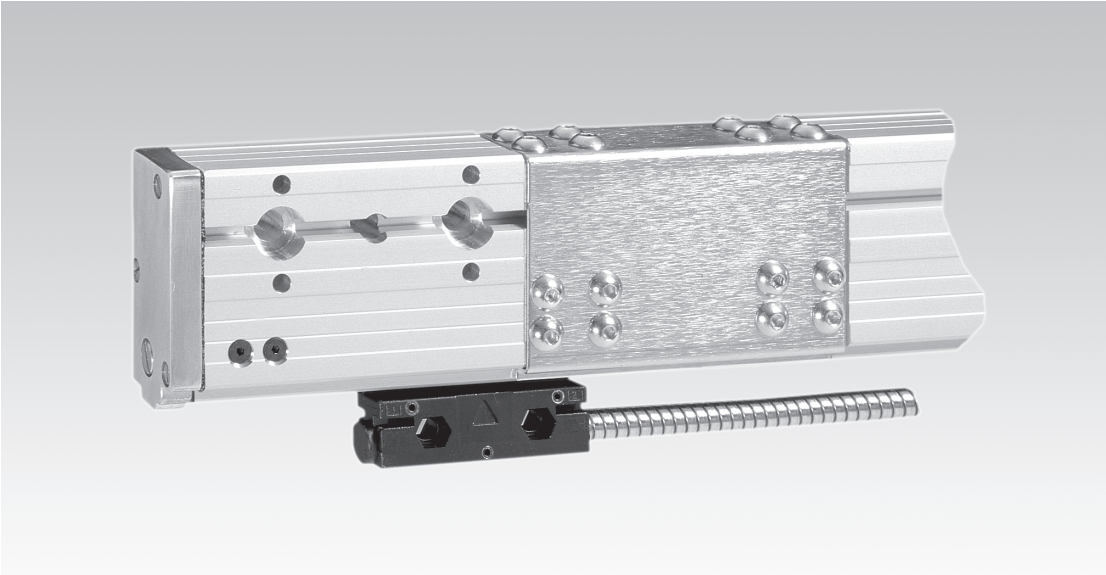

REFERENCE MANUAL

	Page
Introduction	2
Mounting Preparation	3
Mounting Information	4
Encoder Dimensions	5
Mounting Requirements	6
Installation Procedure	7
Tape Tensioning	10

Electrical Shielding	12
Troubleshooting	13
Mechanical Specifications	14
Output Signals and Pin-Outs	15
Electrical Specifications	16
The ACU-RITE Warranty	17
Tool Requirements	18

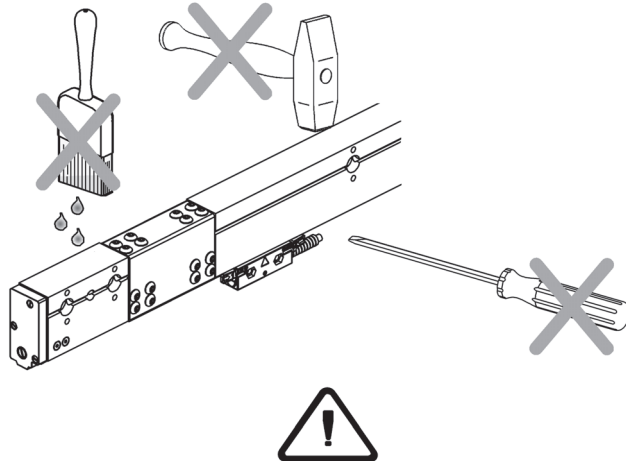

Brackets ...

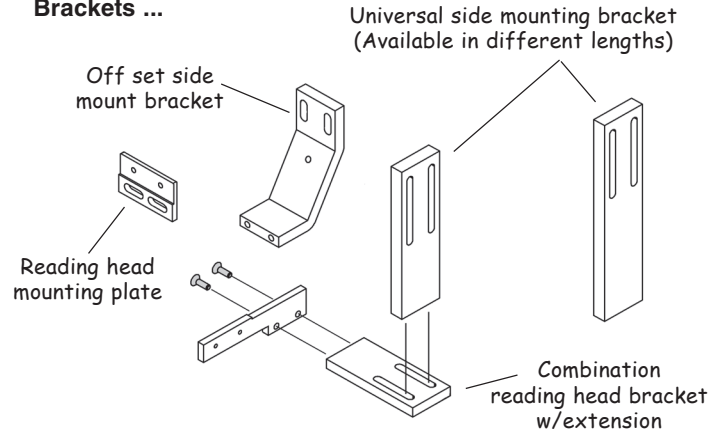

- Installation brackets are available.
- Your authorized distributor can assist you in selecting brackets for your installation.

The ENC 250 linear encoder provides the accuracy and reliability of an Acu-Rite Companies Inc. measuring system with digital output. Features and options include:

- Resolution of [.0002in.] 5µm
- Accuracy grade of +/-15µm/M
- [2 ft.] .61m armor cable and extension cables up to a maximum of [75 ft.] 22.86m for a VRO; [35 ft.] 10.67m for a DRO
- Mounting hardware
- Brackets and accessories

Contact your Authorized Distributor for a complete list of other products and accessories.

For future ordering information or warranty service, record the linear encoder catalog number located on the scale assembly tag, and the serial number from the reading head tag.

	Catalog No.	Serial No.
Axis:	_____	_____
Tape tension value:	_____	
Date of purchase:	_____	
Distributor:	_____	
Address:	_____	
Telephone:	_____	

Contents ...

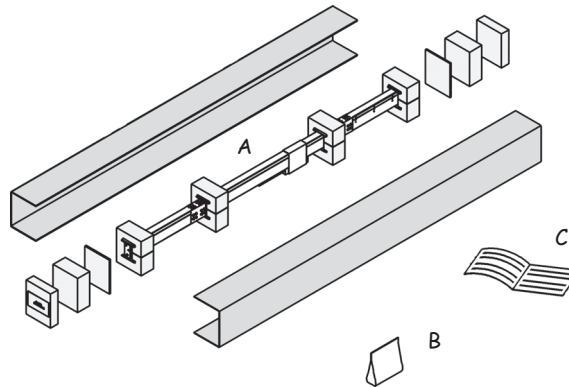

- A • ENC 250 Linear Encoder
- B • Encoder mounting hardware
- C • Reference Manual

Please follow these preparation guide lines.

- Understand your mounting requirements.
- Mount with lip seals down and away from the work area.
- Brackets should be kept as short as possible and rigid.
- Surfaces must be in good condition, clean, and free of dirt. Remove paint from machined mounting surfaces.
- **⚠ Alignment brackets must only be removed as instructed.**

Coolant spray ...

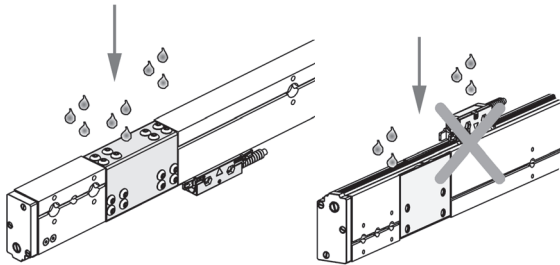

- Encoder lip seals to face away from coolant spray.

Measuring length ...

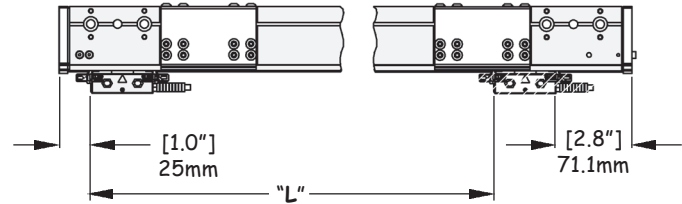

"L" = Measuring length + [2.0"] 50.8mm nominal over travel
Travel is limited by stops at each end of scale

- Machine travel can not exceed the encoder measuring length.
- Either limit machine travel or obtain correct length scale.

Changing cable exit direction ...

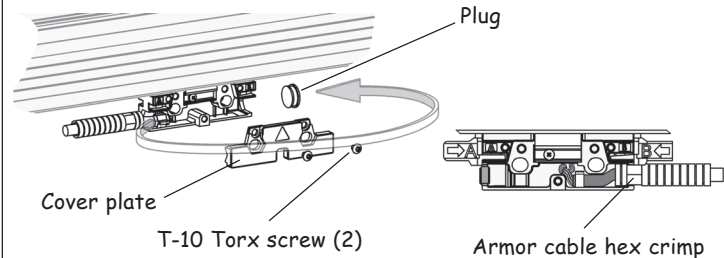

- Determine the cable exit direction before installing the encoder.
- To change the cable exit direction; remove the cover plate and rotate the cable 180°.

Use this information to plan your Linear Encoder installation.

- Mount the linear encoders close to machine guide ways to ensure system accuracy.
- Space between reading head casting and mounting bracket or surface must not exceed [1.188"] 4.7mm.

Alignment bracket removal clearance

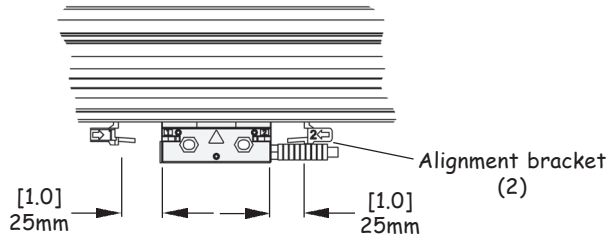

- Allow clearance for alignment bracket removal.
- **⚠ Alignment brackets must not be removed until instructed.**

End of scale clearance requirements

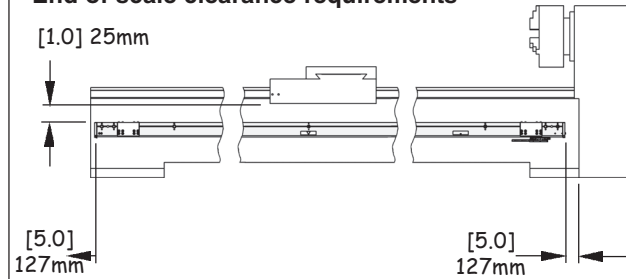

- [1.0] 25mm of clearance is required above the scale case top surface for access to the expansion cover fasteners.
- A minimum clearance of [5.0] 127mm is required at each end of the scale case.

Horizontal mounting

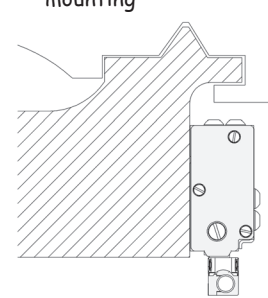

Vertical mounting

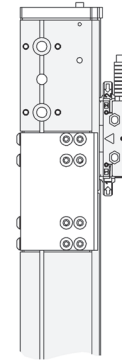

- Mount encoder in a horizontal or vertical position as shown.
- **Do not mount flat or inverted.**

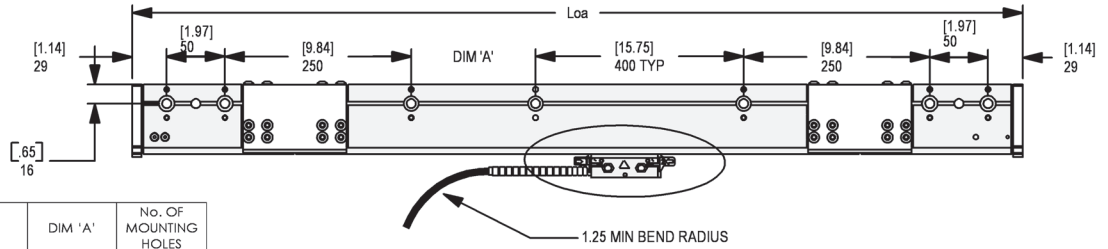

PART NUMBER	MEASURING LENGTH	OVERALL LENGTH LOA	DIM 'A'	No. OF MOUNTING HOLES
385352-50127	3240mm 127"	3458mm 136.14"	400mm 15.748"	12
385352-50135	3440mm 135"	3658mm 144.02"	200mm 7.874"	13
385352-50143	3640mm 143"	3858mm 151.89"	400mm 15.748"	13
385352-50151	3840mm 151"	4058mm 159.76"	200mm 7.874"	14
385352-50159	4040mm 159"	4258mm 167.64"	400mm 15.748"	14
385352-50167	4240mm 167"	4458mm 175.51"	200mm 7.874"	15
385352-50174	4440mm 174"	4658mm 183.39"	400mm 15.748"	15
385352-50183	4640mm 183"	4858mm 191.26"	200mm 7.874"	16
385352-50190	4840mm 190"	5058mm 199.13"	400mm 15.748"	16
385352-50198	5040mm 198"	5258mm 207.01"	200mm 7.874"	17
385352-50206	5240mm 206"	5458mm 214.88"	400mm 15.748"	17
385352-50214	5440mm 214"	5658mm 222.76"	200mm 7.874"	18
385352-50222	5640mm 222"	5858mm 230.63"	400mm 15.748"	18
385352-50230	5840mm 230"	6058mm 238.5"	200mm 7.874"	19
385352-50237	6040mm 237"	6258mm 246.38"	400mm 15.748"	19

LEVELING SCREW HOLES

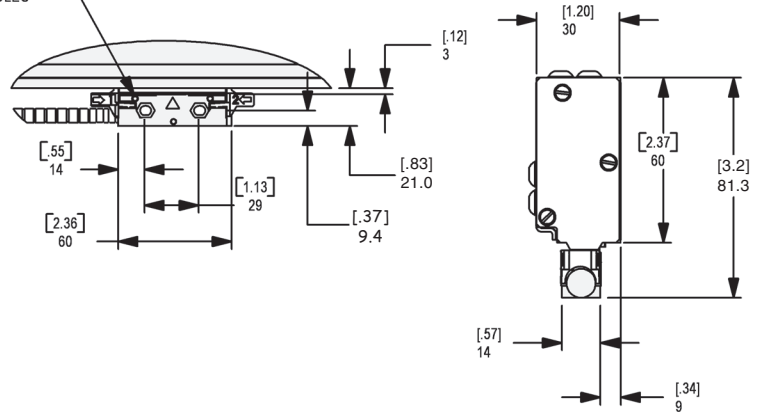

A variety of mounting conditons can be accommodated.

- The machine configuration determimes the brackets required to install the encoder.
- Two typical mounting conditions are shown; reading head mounting plate, and a three piece combination assembly for mounting the reading head to the machine.
- The [8-32] 4mm SHCS for mounting the reading head is a standard low head style fastener, supplied with the mounting hardware.
- The shipping bolts (M5 hex head) must be removed from the expansion covers prior to beginning the installation.
- Tool requirements are listed on page 18.

Three piece combination bracket ...

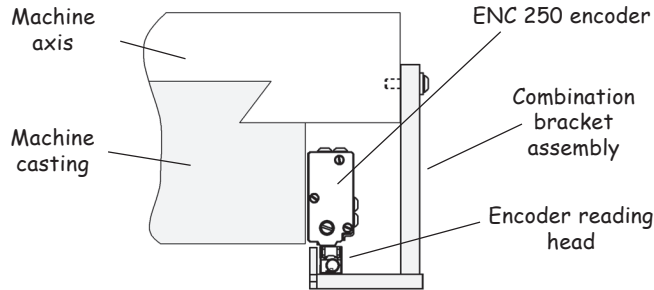

- This combination typically applies to a lathe where the cross feed over hangs the bed mounting surface.
- A wide range of combination lengths are available.

Reading head mounting plate ...

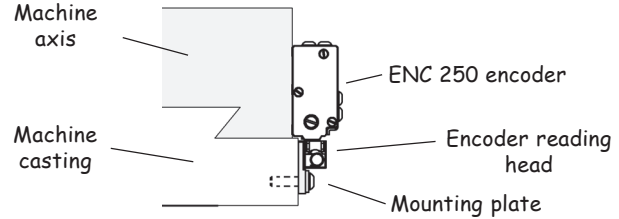

- The mounting plate typically applies to surfaces that are flush, or slightly offset.

Shipping bolts ...

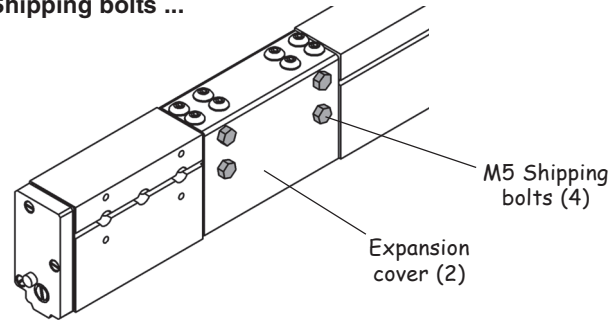

- Remove the M5 shipping bolts prior to encoder installation.

These steps apply to all mounting conditions. Although this may not pictorially represent your application, your installation procedure should follow these steps.

- Adjust drill depths and fastener lengths as required.
- When instructed on page 10, adjust the leveling set screws as follows:
 1. Insert, but do not tighten the [8-32] 4mm reading head screws.
 2. Use a [.001-.003"] .025 - .076mm shim between the leveling set screws and mounting surface.
 3. Adjust each set screw until a slight drag is felt on the shim.
 4. Evenly tighten the [8-32] 4mm reading head mounting screws.
- Contact your Authorized Distributor should you require additional assistance.

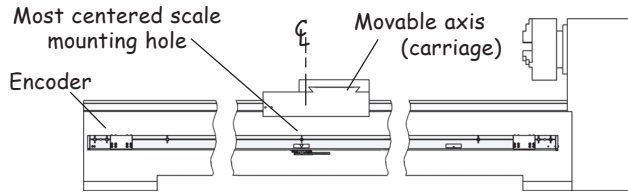

- Move the machine axis to its center of travel.
- Hold the encoder to the intended mounting location, and position for the required clearances. Allow minimal distance required for the reading head brackets.
- Mark the "most centered" scale mounting hole location to the machine with a center punch.
- Remove encoder, drill / tap location for a [1/4-20 x 1/2"] M6 x 12mm deep.

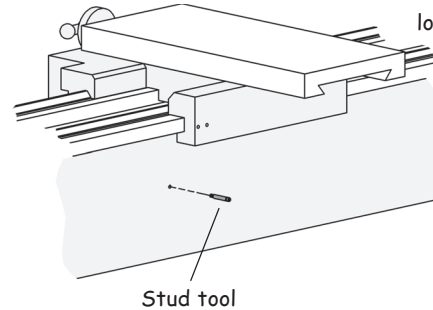

The stud tool is used temporarily to support the encoder while locating the mounting holes

- Attach the 1/4-20 installation stud tool.
- Slide the scale case onto the stud at the same hole location.

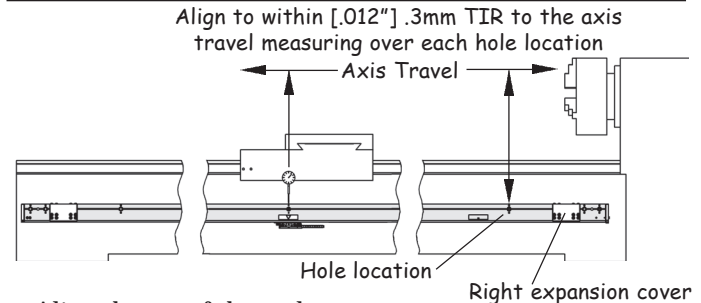

- Align the top of the scale case.
- Transfer punch the furthest right mounting hole location before the expansion cover.
- Allow the scale to swing down, drill / tap location for a [1/4-20 x 1/2"] M6 x 12mm deep.

Align to within [.012"] .3mm TIR to the axis travel measuring over each hole location

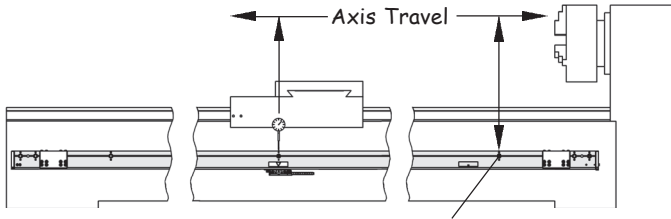

[1/4-20 x 1-1/4"] M6 x 30mm SHCS & M6 flat washer

- Attach and align the top of the scale case. Secure the fastener.

Align to within [.012"] .3mm TIR to the axis travel measuring over each hole location

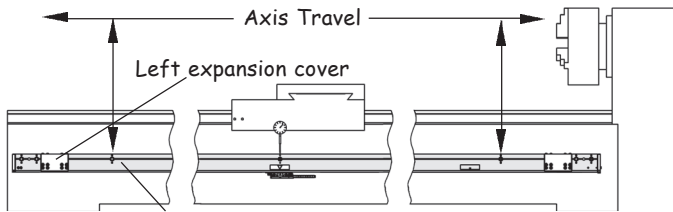

[1/4-20 x 1-1/4"] M6 x 30mm SHCS & M6 flat washer

- Align the furthest left mounting hole before the expansion cover with the furthest right attached hole.
- Transfer punch the left hole location.
- Drill / tap location for a [1/4-20 x 1/2"] M6 x 12mm deep.
- Attach the left end, and align the top of the scale case. Secure the fastener.

Align to within [.012"] .3mm TIR to the axis travel measuring over each hole location

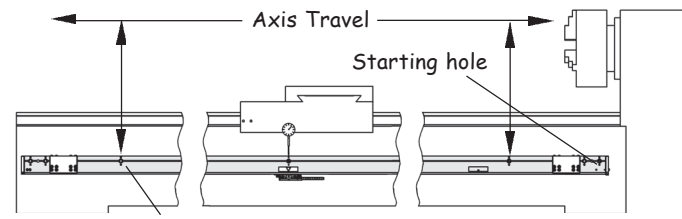

[1/4-20 x 1-1/4"] M6 x 30mm SHCS & M6 flat washer

- Starting at the right end, align the top of the scale case, and transfer punch each remaining hole location.
- **Remove scale**, drill / tap locations for a [1/4-20 x 1/2"] M6 x 12mm deep.
- Attach the scale case, align to within [.012"] .3mm TIR, & secure all fasteners. **Note:** Replace stud with fastener.

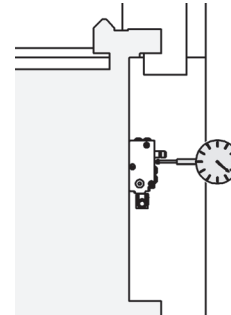

Run an indicator along the front face to locate the high point.

Mark the location, and set the indicator to 0.000"

- Align the front face of the scale case to within [.012"] .3mm TIR of the axis travel following the next steps.

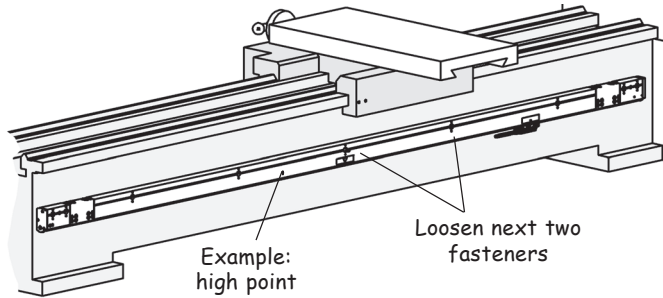

- Loosen the next two fasteners to the right of the high point.
- Move indicator to the first hole location, insert two M3 x 25mm SHSS (leveling set screws).
- Use the leveling screws to align the face to within $[\text{.012}"]$.3mm to the high point along the axis travel and secure the fastener.

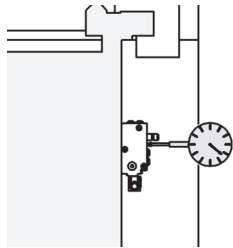

Run indicator along the front face to align scale case to within $[\text{.012}"]$.3mm to the axis travel

- Move indicator to the next hole location, and loosen the next fastener to the right of that fastener. Align this location.
- Repeat the previous steps to align the face at each fastener.
- Return to the high point, and use the same procedure working to the left end.

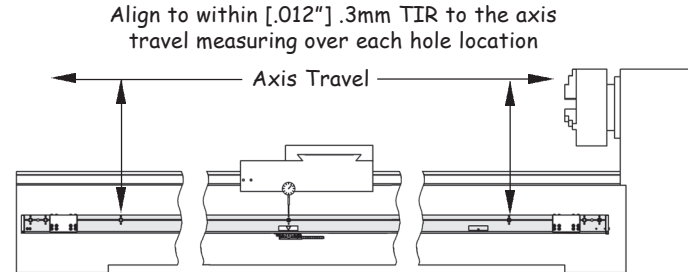

- Recheck the scale case top alignment, by starting at the center hole location, and adjust as necessary.

Dowel pin anchoring ...

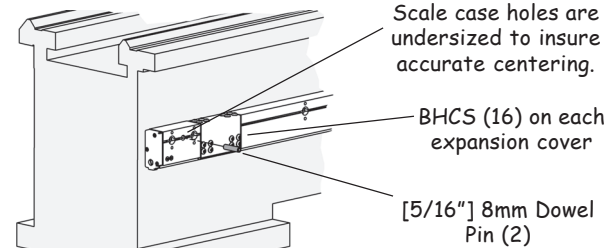

- Drill a $[\text{.302}"]$ 7.7mm diameter hole through the dowel pin hole locations at each end of the scale case $[\text{.375}"]$ 9.5mm deep.
- Use a $[\text{.312}"]$ 8mm reamer to provide a press fit.
- Insert the dowel pins at each end, with the threaded holes facing outward.
- Loosen the BHCS (16) on each expansion cover, approximately $[\text{1/8}"]$ 3mm turn each.

Universal brackets are available from ACU-RITE for mounting the reading head. SENC 150 & SENC 250 encoders use most of the same reading head brackets.

Custom designed brackets by the installer should be solid, rigidly assembled components, attached to the machine with [1/4-20] M6 fasteners minimum.

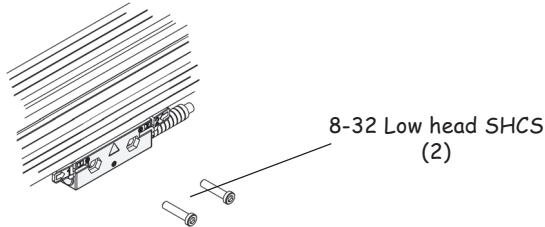

- Return the machine axis to its center of travel.
- Align the center marks on the reading head and scale case by sliding the reading head and brackets along the case.
- Locate and attach the reading head brackets to the machine.
- Align the bracket mounting holes with the reading head holes, and secure brackets in place.
Insert the [8-32] M4 SHCS, BUT DO NOT TIGHTEN.

Slide brackets back away from the reading head and cable

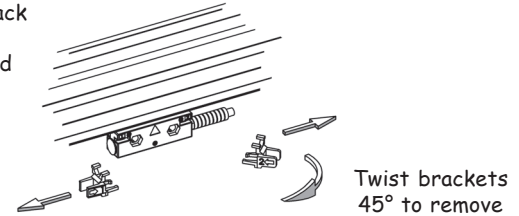

- Follow the procedure on page 7 to attach the reading head to the bracket.
- Use allen wrench from set screw adjustment to slide alignment brackets away from the reading head.
- Remove alignment brackets and save with this manual.
- Move the axis through its full travel. Confirm that the assembly does not interfere with the machine movement.

Tape Tensioning ...

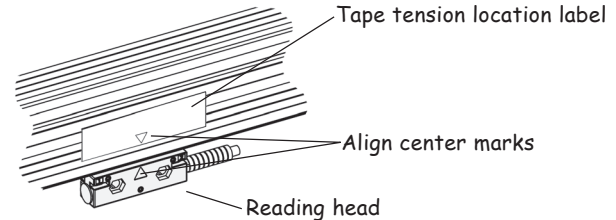

- Move the reading head to the tape tensioning position.
- Temporarily attach the reading head cable to the readout.
- Follow the readout manual's instructions for set up, and set the encoder and display resolution to .005mm. Set the readout in metric mode.

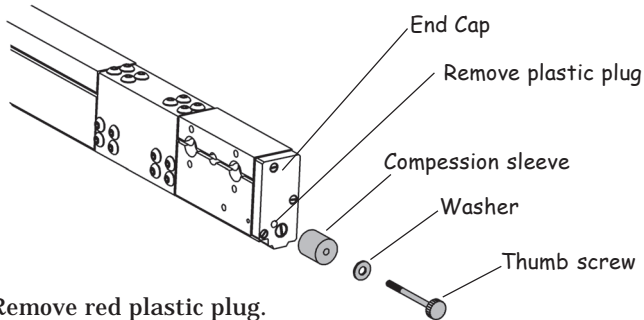

- Remove red plastic plug.
- Insert the thumb screw through the washer, compression sleeve, and into the end cap hole.
- Thread the screw into the holder inside the end cap, but do not tighten.

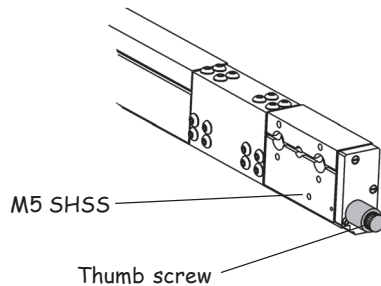

- Completely loosen the M5 SHSS, but do not remove.
- Position the readout so that it can be seen while adjusting the thumb screw head.
- Insure that the readout is in metric mode.

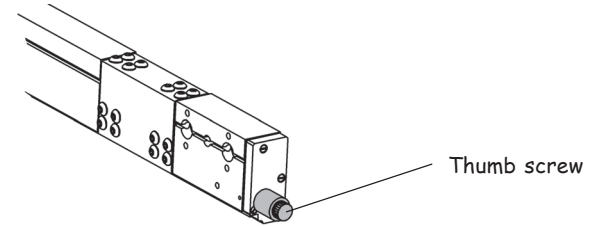

- Tighten the screw until the readout display reads approximately .05mm.
- Back off the screw until the display stops changing.
- Reset readout to zero and repeat the procedure two more times. This relaxes the tape before setting the tension.

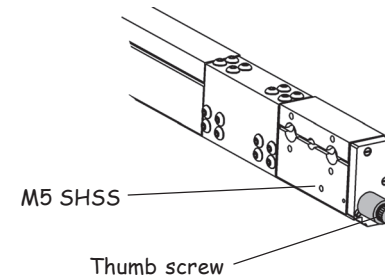

- Refer to the tensioning value listed on the label on the case.
- Slowly tighten the screw until the display reaches the tensioning value.
- Fully tighten the M5 SHSS [30-lb-in] 3.4N m.

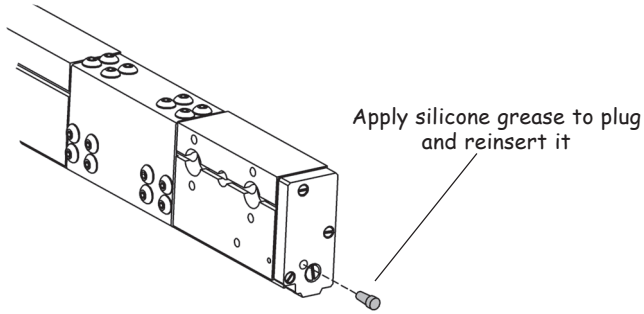

- Remove the thumb screw, sleeve, and washer.
- Apply silicone grease to the plug and reinstall it.

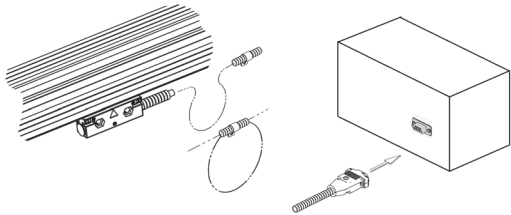

- With the readout properly mounted, route the cable with sufficient slack loops for machine movement to the readout.
- Secure cables by fastening with clips or ties.
- Attach the encoder connectors to the readout.

Electrical shielding ...

- Connect a ground wire from the terminal on the back of the readout to the machine or earth ground.
- Attach a ground wire from the machine to a solid earth ground.
- With the encoder attached to the cable connected to the readout, check shielding by measuring resistance between connector housing and scale unit.

Desired value: 1 ohm max.

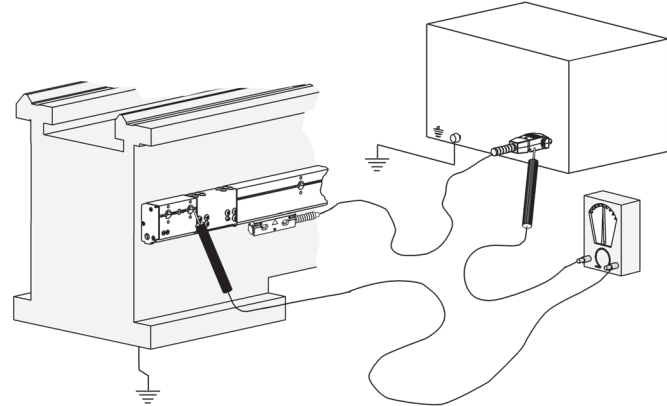

If you experience difficulties with your installation, do the following to determine the problem.

Checking the Readout

Difficulties on more than one axis are usually associated with the readout. Follow these steps to determine if your difficulties are associated with the readout:

- Ensure that the linear encoder connectors are correctly seated.
- Swap linear encoder cables at the readout to see if the problem is still shown in the same display.
- If the problem remains in the same display, the readout may be in error. To determine if that is the problem, repeat above steps with both encoders, but with only one encoder connected at a time. This should allow you to determine if the problem is with the readout or the encoder.
- If the problem follows the connection change, the linear encoder may be in error.

If the Readout is at fault, refer to **“What to do”** to arrange for the parts necessary to repair your system. If a linear encoder appears to be at fault, proceed with **“Checking the Linear Encoders”**.

Checking the Linear Encoders

Problems on a single axis are usually associated with the linear encoder or its installation. Difficulties can be caused by improper installation, loose or misaligned bracketry, or a damaged or inoperable encoder.

Follow these steps to determine the cause of your system difficulties:

- Confirm that your bracketry and installation does not interfere with other machine structures through the entire length of the linear encoder travel.
- Check for loose fasteners. If you find loose fasteners, first confirm that the linear encoder is installed to the tolerances specified and then retighten the fasteners as required.
- Confirm that the linear encoder is installed to the specified alignment tolerances. If the installation does not meet the tolerances, reinstall the encoder according to the **“Installation Procedure”**.
- Do not attempt to repair the reading head or scale assembly. The ENC 250 is field serviceable by assembly replacement only. Attempts to repair the encoder can permanently damage it and void the warranty.

What to do

If an ACU-RITE linear encoder or readout is found to be at fault, please contact your Authorized Distributor for instructions prior to removing the encoders or readout.

Mechanical Specifications	Digital
Resolution	5µm [0.0002 in.]
Grating pitch	100µm [0.00393 in]
Scale medium	Reflective Metal Tape
Accuracy	± 15µm/M [0.00018 in/ft]
Max. slew speed	1 M/sec [40 in/sec.]
Force required to move reading head	± 3.3 Newtons [0.75 lbs]
Operating Environment: Temperature Relative Humidity	0° to 40° C [32° to 104°F] 20% to 95% (non-condensing)
Storage Environment: Temperature Humidity	-40° to 60° C [-40° to 140°F] 20% to 95% (non-condensing)
Weight w/cable	1 kg + 3.2kg/M [2.2 lbs. + 0.18 lbs/in] of measuring length
Connecting cable: Armor	Length = .61m [2 ft] Connector: DE-9P
Max. cable length	22.9m [75 ft.] VRO / 10.7m [35 ft.] DRO
Measuring length	3240mm [127"] - 6040mm [237"]
Reference Mark Interval	100mm [3.937"] Distance encrypted

Output Signals and Pin-Outs

Digital Differential

Pin 1	Pin 2	Pin 3	Pin 4	Pin 5	Pin 6	Pin 7	Pin 8	Pin 9
N/C	Green	Yellow	Blue	Red	White	Brown	Pink	Gray
N/C	Channel A+	Channel A-	Channel B+	Channel B-	Ground	Vcc, + 5.1 ± 0.1 VDC	Channel R+	Channel R-

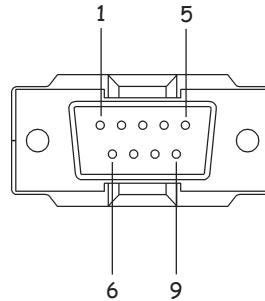
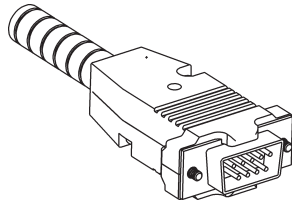

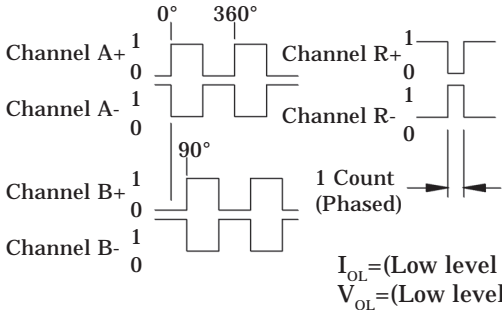
Parameter	Digital
Output Signals	<p> I_{OH}=(High level output current) = 20mA V_{OH}=(High level output voltage) >2.5Vdc </p>  <p> I_{OL}=(Low level output current) = 20mA V_{OL}=(Low level output voltage) < 0.5Vdc </p>
Incremental signals	<p>Square-wave voltage signals. Channels A and B, in 90° quadrature relationship</p>
Signal levels	<p>Differential TTL</p>
Reference Mark signals	<p>Square-wave pulse</p>
Signal level	<p>Differential TTL</p>
Power Supply	<p>5.1 ± 0.1 VDC @ 140 mA max.</p>

3 Year Warranty ...

Acu-Rite Companies Inc. readouts and precision scales are warranted to the end user against defects in material and workmanship, and against any damage that occurs to the product within three (3) years from the original purchase date. Acu-Rite Companies Inc. will, at its discretion and expense, repair or replace the returned item or any of the item's component(s) as long as Acu-Rite Companies Inc. receives notice of the defect or damage within the three (3) year warranty period.

The foregoing warranty obligations are in lieu of all expressed and/or implied warranties of fitness or merchantability or otherwise, and state Acu-Rite Companies Inc. entire liability and the end user's exclusive remedy, under any circumstances, for any claim of damage.

In no event shall Acu-Rite Companies Inc. be liable for incidental or consequential damages nor shall Acu-Rite Companies Inc. liability for claims or damage arising out of or connected with this warranty or the manufacture, sale, delivery, or use of the products with which this warranty is concerned exceed the purchase price of said products.

You will need the following tools to complete the installation:

- 0.001" Dial Indicator with Magnetic Base
- English Hex Wrench Set
- Metric Hex Wrench Set
- Dial Calipers
- Feeler Gage
- Hand Drill
- Hand Tap
- Taps(English): 1/4-20 UNC & #8-32 UNC
- Taps(Metric): M6, M4
- Drills(English): #7 (.201"), #29 (.136"), N (.302")
- Drills(Metric): 5mm, 3.3mm, 7.7mm
- Reamer(English): .312"
- Reamer(Metric): 8mm
- Transfer Punch Set
- Hammer
- Center Punch
- Phillips Screw Driver
- Flat-tip Screw Driver

* NOTE: Both English and metric mounting hardware have been supplied. The mounting instructions reference to both. Tools required depend on the fasteners being used.

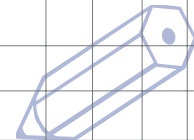

Acu-Rite Companies Inc.
IS AN
ISO 9001
CERTIFIED
MANUFACTURER



One Precision Way • Jamestown, NY 14701

Acu-Rite Companies Inc.

104000-028 EDITION C 7/07

