

# ENC 125 T/E

---



REFERENCE MANUAL



|  |      |
|--|------|
|  | Page |
| Introduction .....                               | 2    |
| Mounting Preparation .....                       | 3    |
| Mounting Information .....                       | 4    |
| Encoder Dimensions - ENC 125 T (top mount) ..... | 5    |
| Encoder Dimensions - ENC 125 E (end mount) ..... | 6    |
| Mounting Requirements .....                      | 7    |
| Typical Mounting (s) .....                       | 8    |
| Encoder Installation Procedure .....             | 9    |

|  |      |
|--|------|
|  | Page |
| Checking your Installation .....           | 12   |
| Electrical Shielding .....                 | 13   |
| Troubleshooting .....                      | 14   |
| Mechanical Specifications .....            | 15   |
| Output Signals and Pin-Outs .....          | 16   |
| Electrical Specifications .....            | 17   |
| The Acu-Rite Companies Inc. Warranty ..... | 18   |

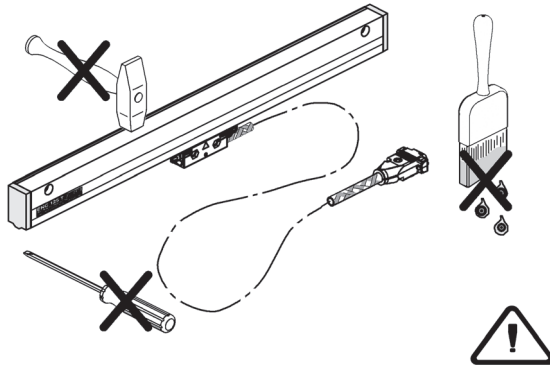

**Brackets ...**

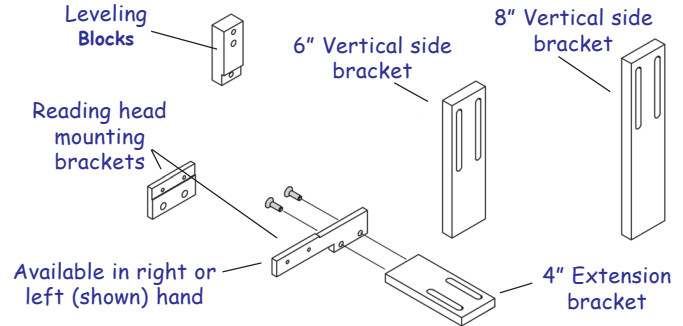

- Installation brackets and kits are available.
- Your authorized distributor can assist you in selecting brackets for your installation.

The ENC 125 T and E Precision Glass Scale Linear Encoders provides the accuracy and reliability of an Acu-Rite Companies Inc. measuring system.

Features include:

- Resolutions of 5µm and 10µm.
- Accuracy Grade of ± 10µm/1000mm.
- Reference signals on 100mm intervals.
- Braided cables: 42"≤ encoders - 13 ft. length.  
42"> encoders - 19 ft. length.
- Two scale case forms:
  - ENC 125 T: Top mount scale; 2" - 120" measuring length
  - ENC 125 E: End mount scale; 2" - 22" measuring length
- Mounting fasteners provided with scale.
- Mounting brackets available.

For future ordering information or warranty service, record the linear encoder catalog number located on the scale assembly tag, and the serial number from the reading head tag.

|                   | Catalog No. | Serial No. |
|-------------------|-------------|------------|
| Axis # 1:         | _____       | _____      |
| Axis # 2:         | _____       | _____      |
| Axis # 3:         | _____       | _____      |
| Axis # 4:         | _____       | _____      |
| Date of purchase: | _____       |            |
| Distributor:      | _____       |            |
| Address:          | _____       |            |
| Telephone:        | _____       |            |

**Shipping carton contents**

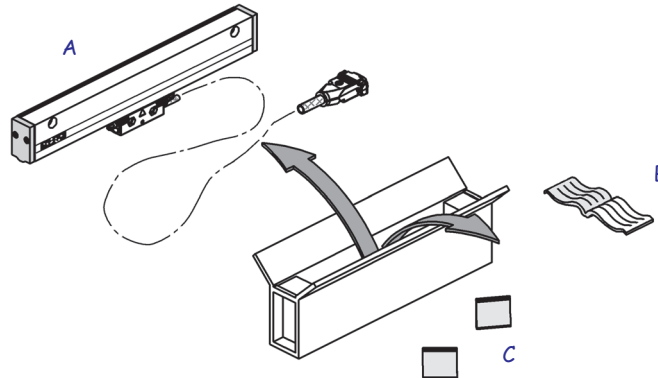

- A • ENC 125 T or E linear encoder
- B • Reference Manual
- C • Encoder and Cable mounting hardware

Please follow these preparation guide lines.

- Understand your mounting requirements.
- Mount with lip seals down and away from the work area.
- Brackets should be kept as short and rigid as possible.
- Surfaces must be in good condition, clean, and free of dirt. Remove paint from machined surfaces used for mounting.
- **⚠ Alignment brackets must not be removed until instructed.**

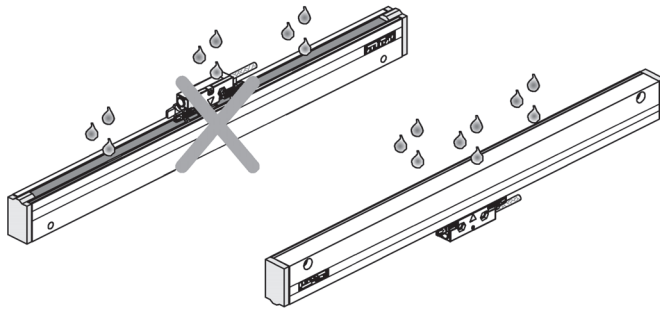

- Never mount with lip seals upward or towards work area.

## ENC 125 T

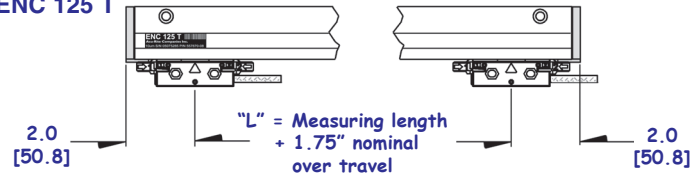

## ENC 125 E

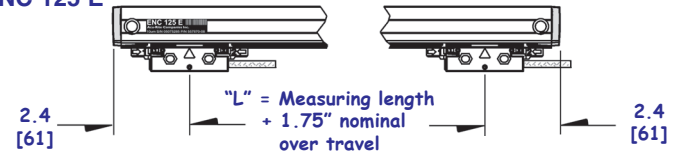

- Machine travel can not exceed the encoder measuring length.
- Either limit machine travel or use correct length scale.

## Cable direction

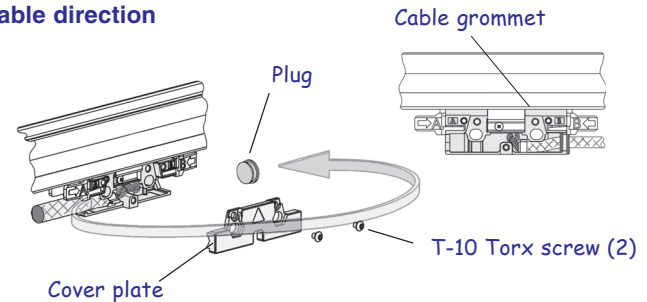

- Determine the cable exit direction before installing the encoder.
- To change the cable exit direction; remove the cover plate and rotate the cable 180°.

Use this information to plan your Linear Encoder installation.

- Mount the linear encoders close to machine guide ways to ensure system accuracy.
- If space between the reading head and the mounting surface exceeds .18", use a mounting bracket or spacer to reduce space.
- Acu-Rite Companies Inc. bracket kit instructions provide step by step installation procedures.

### Alignment bracket removal clearance

(ENC 125 E end mounting scale case shown for reference)

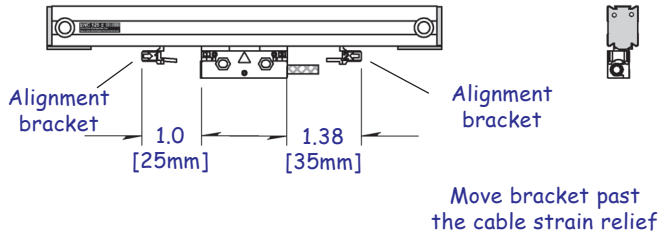

- Clearance requirements for alignment bracket removal.
- **⚠ Alignment brackets must not be removed until instructed.**

### Tolerances ...

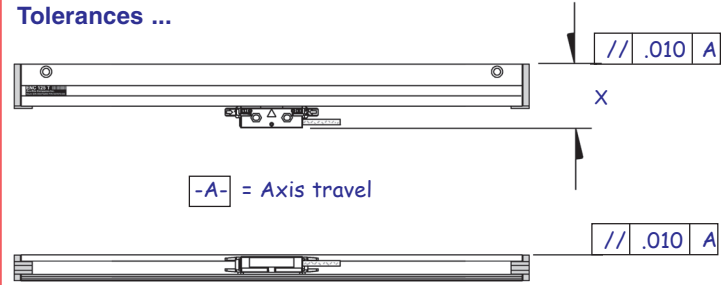

- Tolerances of .010" TIR apply to all mounting dimensions.
- Top mounted form X= 2.37".
- End mounted form X= 1.90".

### Offset mounting

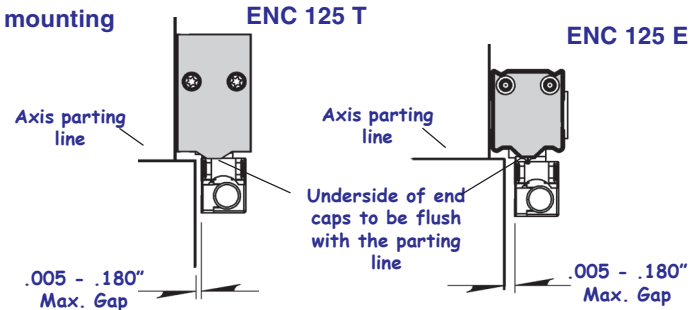

- Use reading head leveling set screws.
- Reading head bracket required for a space >.18".

ENC 125 T

(top mounted scale case)

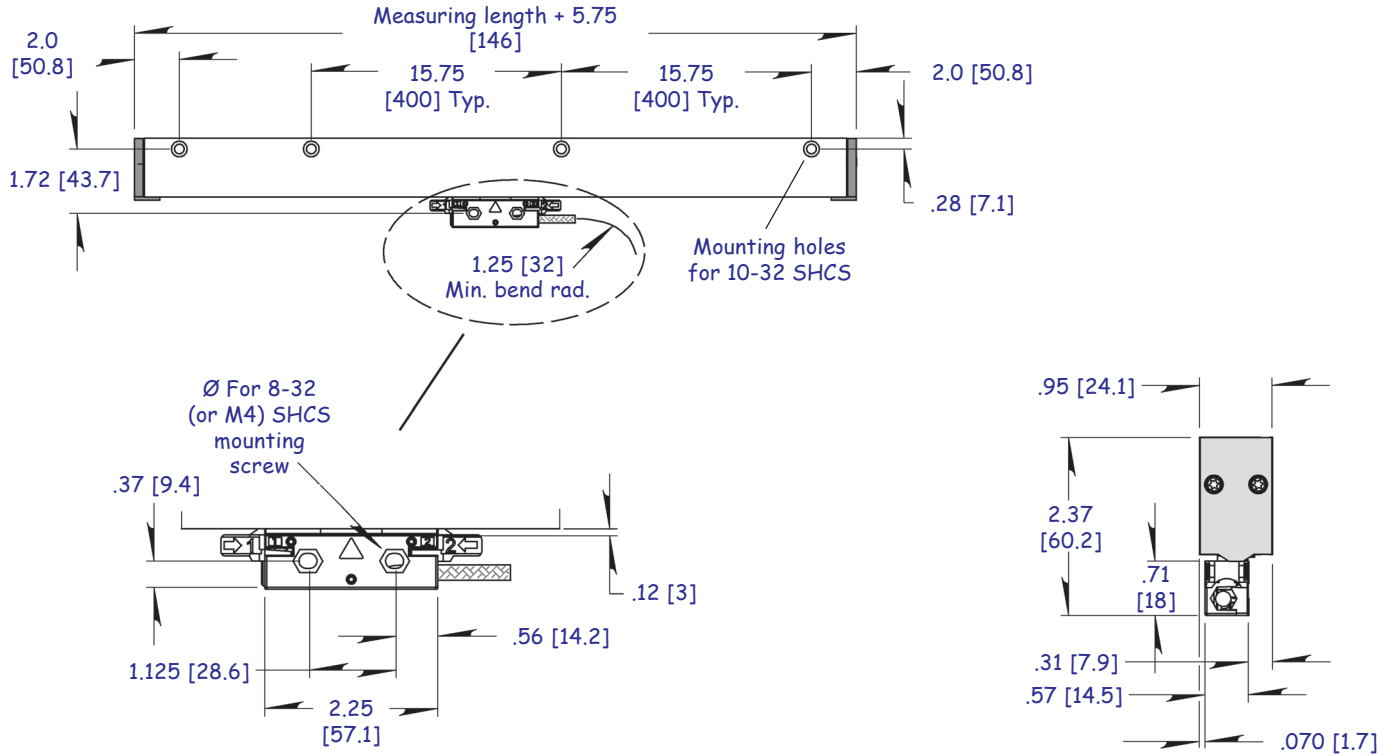

## ENC 125 E

(end mounted scale case)

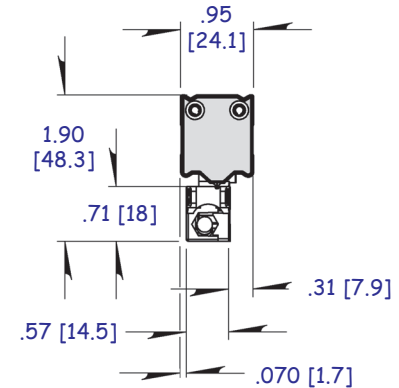
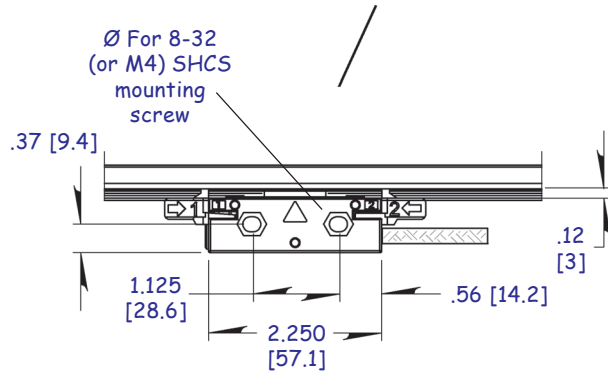
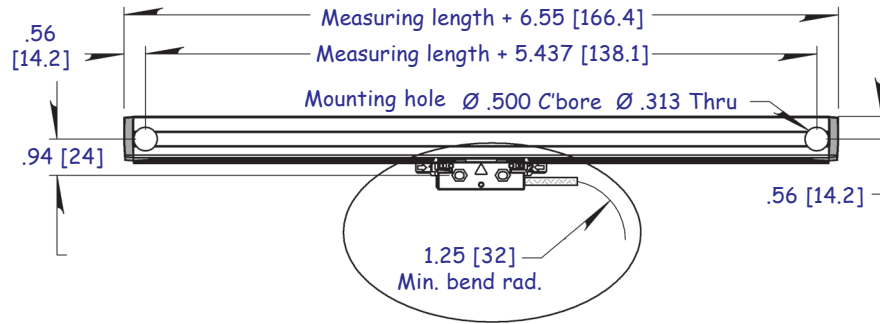



Mounting options can be adapted to machine mounting surfaces using spacers, standoffs, leveling set screws. A spar can be used for the ENC 125 E encoder.

- Measuring length and mechanical configuration of your machine determine your options.
- Fastener lengths described on this page are included with the encoder or the backup spar.

**ENC 125 T**

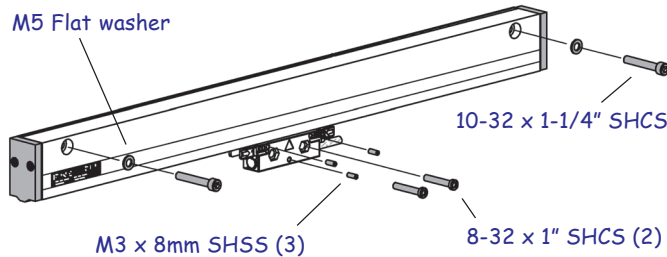

- Mounting can be direct to the machine surface or with the aid of leveling blocks or spacers.

**ENC 125 E**

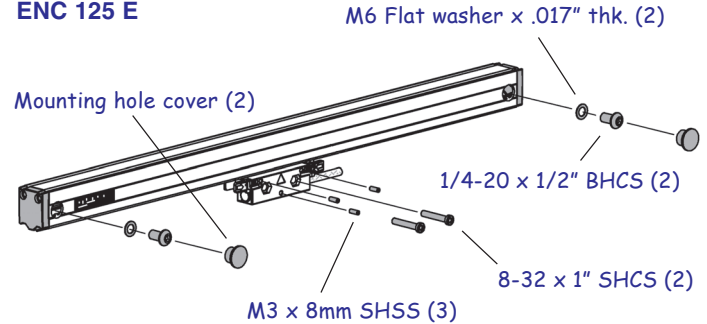

- Mounting can be direct to the machine surface or with the aid of leveling blocks, spacers or back up spar.

**Backup spar mounting for ENC 125 E encoder**

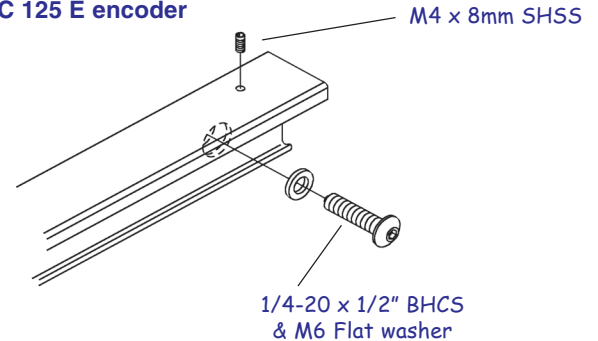

- For use with ENC 125 E scale case only.

A variety of mounting conditions can be accommodated.

- The machine configuration determines the brackets and encoder style required for installation.
- Typical mounting conditions are shown; flush with reading head bracket, and ENC 125 E encoder with backup spar.
- The 8-32 SHCS for mounting the reading head is a standard low head style fastener.

### Flush mounting surfaces ENC 125 T

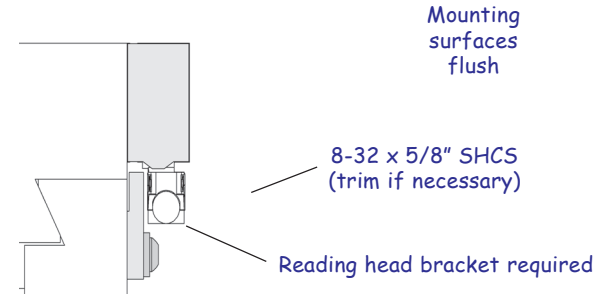

- Flush mounting surfaces, reading head bracket required.
- Bracket used to reduce head to mounting surface offset.
- Use reading head leveling screws for alignment.

### Flush mounting surfaces ENC 125 E

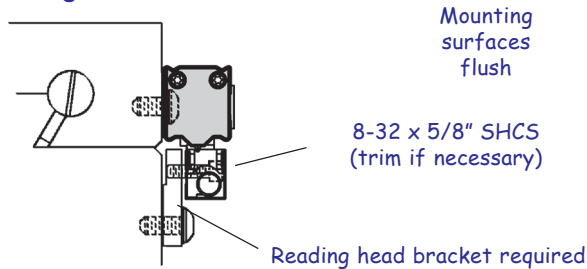

- Flush mounting surfaces, reading head bracket required.
- Bracket used to reduce head to mounting surface offset.
- Use reading head leveling screws for alignment.

### Backup spar & bracket

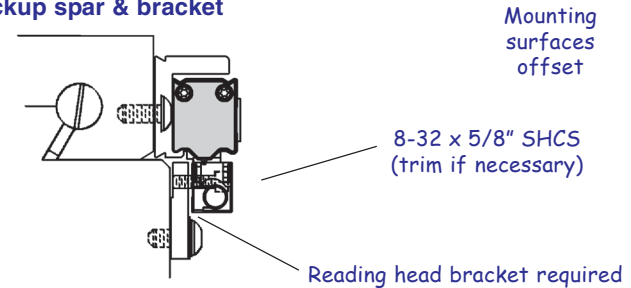

- Offset mounting surfaces with a backup spar.
- Bracket used to reduce head to mounting surface gap.
- Use reading head leveling set screws for alignment.

These steps apply to typical encoder mounting conditions and assumes the mounting surface is parallel to the machine travel to within .010".

- Acu-Rite Companies Inc. bracket kit instructions supercede this section.
- Adjust drill depths and fastener lengths as required.
- Contact your authorized Distributor should you require additional assistance.

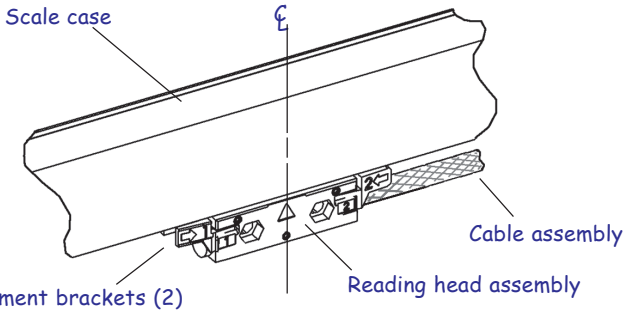

- Move the reading head to the center of the scale case by sliding the reading head and brackets along the case.

### Center mounting axis

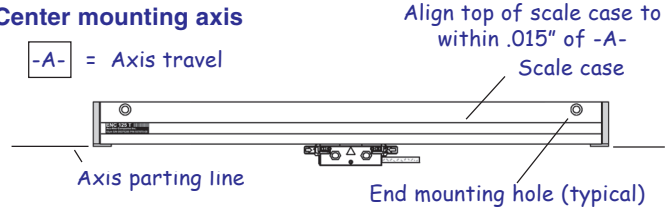

- Move the machine axis to its center of travel and mark the axis for future reference.
- Locate the encoder so that a suitable mounting position is provided for both the scale case and the reading head. Keep the underside of end caps approximately flush with the underside of the table (or axis parting line).
- Mark the location of one end mounting hole to the mounting surface and remove encoder.

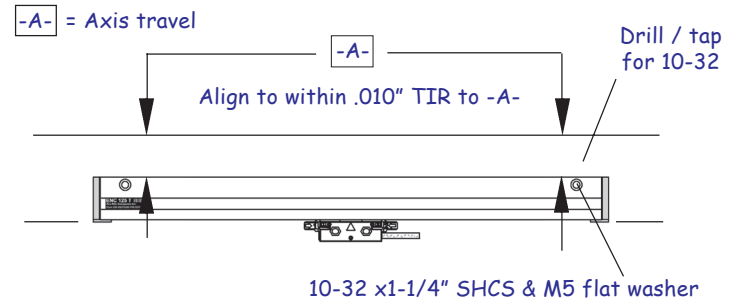

- Drill & tap the first end mounting hole location.
- Attach the encoder and align to within .010" TIR. to -A-.
- Transfer punch the remaining mounting holes and remove the encoder.

-A- = Axis travel

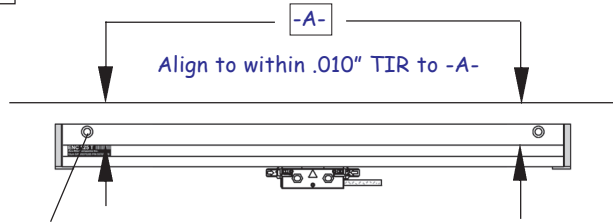

10-32 x 1-1/4" SHCS & M5 flat washer

- Drill / tap the remaining mounting holes.
- Attach the encoder and align the face and the top of the scale case to within .010" TIR to -A- (refer to page 4, "Tolerances").
- Secure the encoder in place maintaining this alignment.

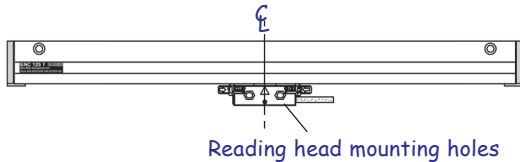

- Return the table to the center of travel. Move the reading head to the center of the scale case.
- Transfer punch the two reading head mounting holes. If using a reading head bracket, use the next step.
- Slide the reading head to one side, and drill and tap the hole locations for an 8-32 x 1/2" deep.

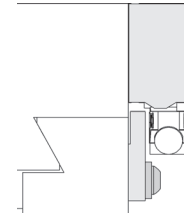

Reading head bracket

- Attach the bracket to the reading head with the 8-32 x 5/8" BHCS.
- Transfer punch the two reading head bracket mounting holes to the machine.
- Remove the bracket, drill and tap the hole locations for an 1/4-20 x 1/2" deep. Attach the bracket to the machine with (2) 1/4-20 x .5" BHCS and washers.

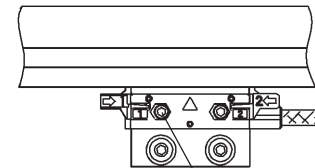
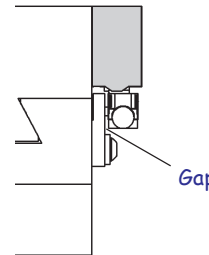

8-32 x 5/8" SHCS  
(M4 x 20mm)

**⚠ Do not tighten prior to adjusting leveling set screws**

- Insert, but do not tighten 8-32 (M4) reading head screws.
- A gap will exist between the reading head and the bracket.

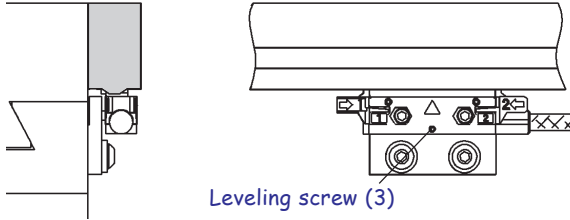

- Place a .001"-.003" shim between the leveling set screws and mounting surface.
- Adjust each set screw until a slight drag is felt on the shim.
- **Evenly tighten the 8-32 (M4) reading head mounting screws.**

### Alignment bracket removal

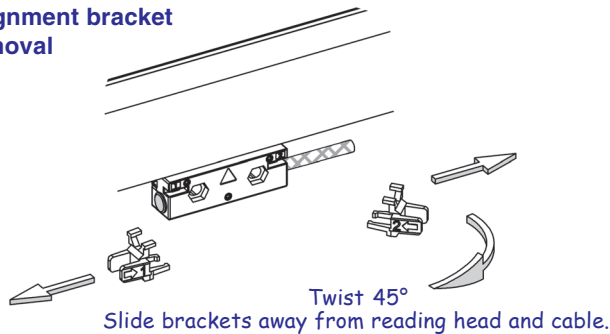

- Slide the brackets away from the reading head.
- Remove the alignment brackets and save for future use.

### Connecting

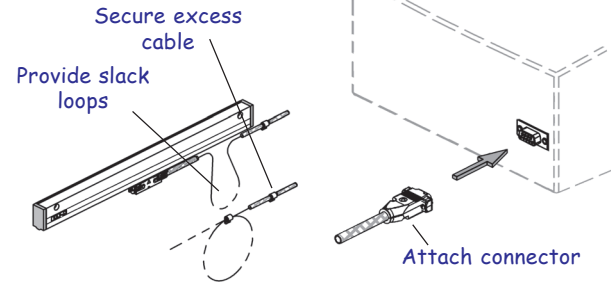

- Route the cables with slack loops to allow for axis motion.
- Secure excess cable by fastening with clips or ties.
- Attach the linear encoder connectors to the readout.

These steps will confirm proper operation of your installation. The counting Test confirms proper electrical operation. The Repeatability Test checks the installation integrity

### Counting Test:

- Configure the readout's encoder and display resolution (see manual).
- Move the axis and compare the display to the movement.

### Repeatability Test:

- Locate an indicator on one end of the encoder and zero the readout and indicator.
- Move the axis through the full travel and return to dial zero.
- Readout should read zero  $\pm 1$  count.

### Counting Test

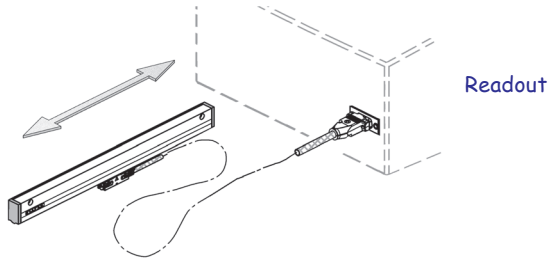

- Move the axis and compare the display to the movement.

### Repeatability Test

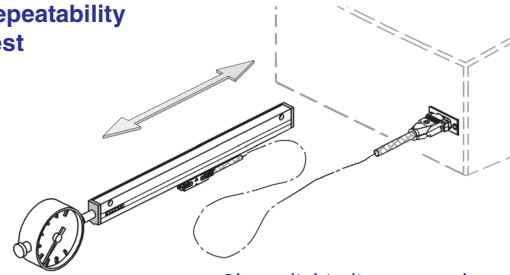

Place dial indicator at the end of the moving component (scale assembly or reading head).

- Zero the display and indicator.
- Move axis to the end of its travel return to dial zero.
- Readout should read zero  $\pm 1$  count.

Connect a ground wire from the terminal on the back of the readout to the machine or earth ground. Attach a ground wire from the machine to a solid earth ground.

With the encoder attached to the machine and the cable connected to the readout, check shielding by measuring resistance between connector housing and scale unit.

**Desired value: 1 W max.**

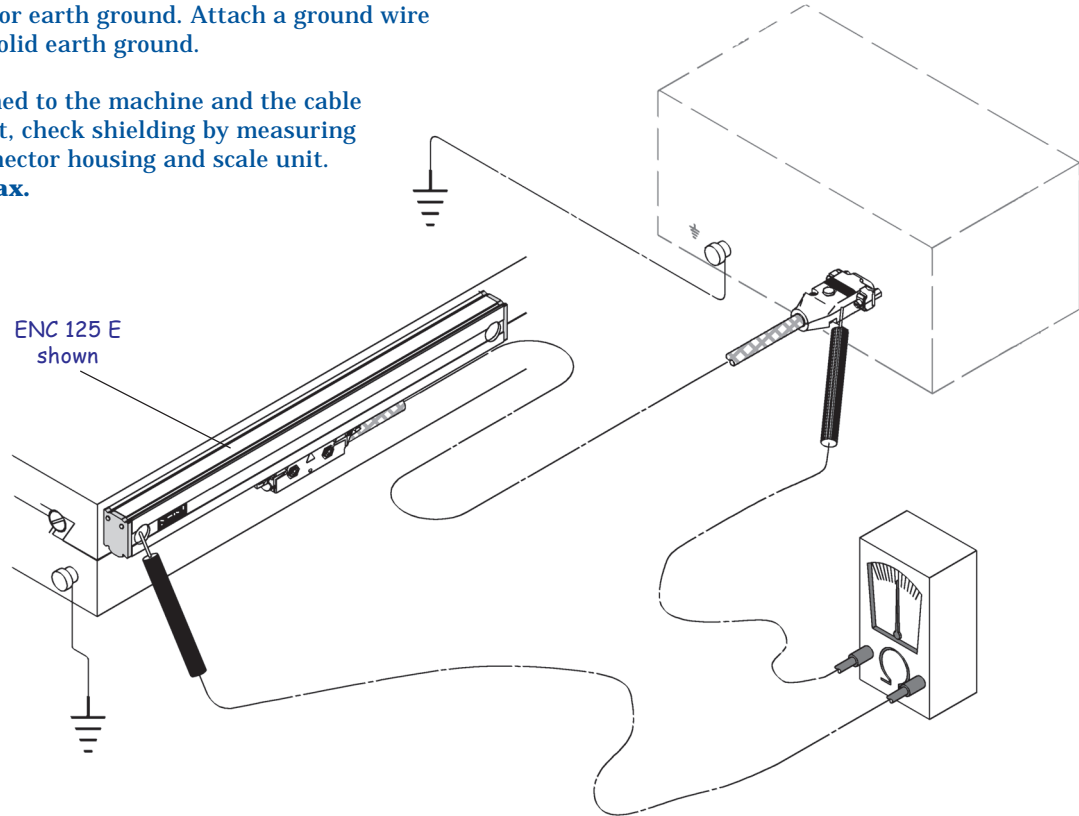

If you experience difficulties with your installation, do the following to determine the problem.

### Checking the Readout

Difficulties on more than one axis are usually associated with the readout. Follow these steps to determine if your difficulties are associated with the readout:

- Insure that the linear encoder connectors are correctly seated.
- Swap linear encoder cables at the readout to see if the problem is still shown in the same display.
- If the problem remains in the same display, the readout is in error.
- If the problem follows the connection change, the linear encoder may be in error.

If the Readout is at fault, refer to “**What to do**” to arrange for the parts necessary to repair your system. If a linear encoder appears to be at fault, proceed with “**Checking the Linear Encoders**”.

### Checking the Linear Encoders

Problems on a single axis are usually associated with the linear encoder or its installation. Difficulties can be caused by improper installation, loose or misaligned bracketry, or a damaged or inoperable encoder.

Follow these steps to determine the cause of your system difficulties:

- Confirm that your bracketry and installation does not interfere with other machine structures through the entire length of the linear encoder travel.
- Check for loose fasteners. If you find loose fasteners, first confirm that the linear encoder is installed to the tolerances specified and then retighten the fasteners as required.
- Confirm that the linear encoder is installed to the required tolerances by checking the alignment tolerances specified on Page 4. If the installation does not meet the tolerances, reinstall the encoder according to the “**Installation Procedure**”.
- Perform a Repeatability Test as described on Page 11. If the linear encoder is installed to the required tolerances, the bracketry and encoder have been checked for interferences and loose fasteners, and the encoder fails the repeatability test, the encoder is likely at fault.

Do not attempt to repair the reading head or scale assembly. The ENC 125 is field serviceable by assembly replacement only. Attempts to repair the encoder can permanently damage it and void the warranty.

### What to do

If an Acu-Rite Companies Inc. linear encoder or readout is found to be at fault, please contact your authorized Distributor for instructions prior to removing the encoders or readout .



| <b>Mechanical Specifications</b>                           | <b>Digital</b>   |
|--|--|
| Resolution   | 5 $\mu$ m, & 10 $\mu$ m  |
| Grating pitch  | 40 $\mu$ m   |
| Scale medium   | Light transmission through chrome-coated glass   |
| Accuracy (@ 20° C)   | $\pm$ 10 $\mu$ m/ 1000mm   |
| Max. slew speed  | 30 inches/sec  |
| Force required to move reading head                        | $\leq$ 0.75 lbs  |
| Operating Environment:<br>Temperature<br>Relative Humidity | 0° to 40° C<br>25% to 95% (non-condensing)   |
| Storage Environment:<br>Temperature<br>Humidity            | -20° to 65° C<br>20% to 95% (non-condensing)   |
| Weight w/cable ENC 125 T                                   | 1.3 lbs. + 0.05 lbs/in of measuring length   |
| Weight w/cable ENC 125 E                                   | 1.3 lbs. + 0.11 lbs/in of measuring length   |
| Connecting Braided cable                                   | Length = 13 ft (4m) cable for ML $\leq$ 42"<br>Length = 19 ft (6m) cable for ML >42"<br>Connector: DE-9P |
| Max. cable length  | 35 ft  |
| Measuring lengths - ENC 125 T                              | 2" - 120"  |
| Measuring lengths - ENC 125 E                              | 2" - 22"   |
| Reference Pulse Interval                                   | 200mm  |
| Repeatability  | Within one resolution count  |
| Protection (IEC 529)                                       | IP 53 when installed as per instructions   |

## Digital Differential

| Pin 1 | Pin 2         | Pin 3 | Pin 4         | Pin 5 | Pin 6  | Pin 7                       | Pin 8         | Pin 9 |
|-------|---------------|-------|---------------|-------|--------|-----------------------------|---------------|-------|
| -     | Green         | -     | Blue          | -     | White  | Brown                       | Pink          | -     |
|       | Channel<br>A+ |       | Channel<br>B+ |       | Ground | Vcc, + 5.1<br>$\pm 0.1$ VDC | Channel<br>R+ |       |

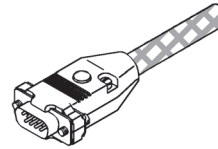
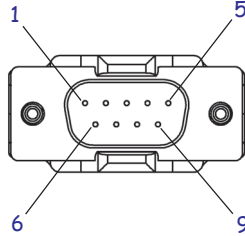

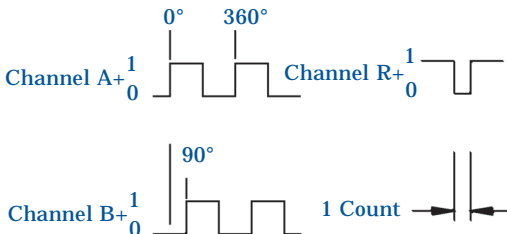
| Parameter              | Digital   |
|------------------------|---|
| Output Signals         | <p> <math>I_{OH}</math>=(High level output current) = 20mA<br/> <math>V_{OH}</math>=(High level output voltage) &gt;2.5Vdc                 </p>  <p> <math>I_{OL}</math>=(Low level output current) = 20mA<br/> <math>V_{OL}</math>=(Low level output voltage) &lt; 0.5Vdc                 </p> |
| Incremental signals    | <p>Square-wave voltage signals.<br/>Channels A and B, in 90° quadrature relationship</p>  |
| Signal levels          | TTL-level   |
| Reference Mark signals | Square-wave pulse   |
| Signal level           | TTL-level   |
| Power Supply           | 5.1 ± 0.1 VDC @ 100 mA max.   |

Acu-Rite Companies Inc. products and accessories are warranted against defects in material and workmanship for a period of three years from the date of purchase. Acu-Rite Companies Inc. will, at its option and expense, repair or replace any part of the Acu-Rite Companies Inc. product which fails to meet this warranty. This warranty covers both materials and factory service labor. In addition, authorized Acu-Rite Companies Inc. service representatives will provide service labor (field service) for a one-year period at no charge. Notice of the claimed defect must be received by Acu-Rite Companies Inc. within the warranty period.

This warranty applies only to products and accessories installed and operated in accordance with this reference manual. Acu-Rite Companies Inc. shall have no obligation, with respect to any defect or other condition caused in whole or part by the customer's incorrect use, improper maintenance, modification of the equipment, or by the repair or maintenance of the product by any person except those deemed by Acu-Rite Companies Inc. to be qualified.

Responsibility for loss of operation or diminished performance due to environmental conditions such as humidity, dust, corrosive chemicals, deposition of oil or other foreign matter, spillage, or other conditions beyond Acu-Rite Companies Inc.'s control can not be accepted by Acu-Rite Companies Inc.

There are no other warranties expressed or implied, and Acu-Rite Companies Inc. shall not be liable under any circumstances for consequential damages.

### **3 Year Hassle Free Warranty**

Keep the box and packing materials

Acu-Rite Companies Inc. is proud to offer the 3 Year Hassle-Free Warranty for all precision glass scales. This warranty will cover all of the Acu-Rite Companies Inc. repair and replacement costs for any precision glass scale returned during the three-year warranty period. Acu-Rite Companies Inc. will repair or replace the damaged components - regardless of the product's condition absolutely free, no questions asked.

Notes



Notes

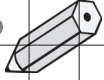



**Acu-Rite Companies Inc.**  
**IS AN**  
**ISO 9001**  
**CERTIFIED**  
**MANUFACTURER**



**Acu-Rite Companies Inc.**

One Precision Way • Jamestown, NY 14701

516289-20 5/06

