

BATTERY = SOLDERED IN PANASONIC CR2354 3V

MASTER-G

Master-G

Digital Readout System

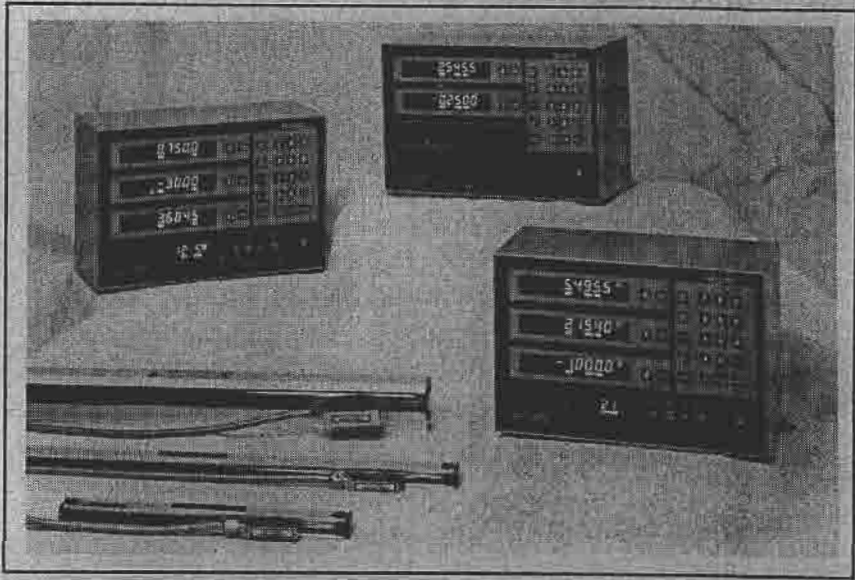

REFERENCE MANUAL

ACU-RITE®



Master readout parameter access code

An access code must be entered before axis and system parameters can be set or changed. This prevents inadvertently resetting parameters.

IMPORTANT

The access code is 8891

Refer to Section 1. Master measuring system setup operations. Begin the parameter setup mode from the DRO mode by pressing the 2ND and SET SYS keys; a "Code _ _ _ _" message is displayed. Press the 8, 8, 9, and 1 keys. The "code" message is replaced with "Set sys", indicating that the Master readout is ready for parameter setting operations. Set parameters as described in Section 2.

IMPORTANT

Supervisors may wish to remove this page from the Master manual after initially setting up the readout system. Keep it in a safe place for future use.

Table of Contents

Section 1. INSTALLATION

Introduction	1-1
<input type="checkbox"/> Accessories	1-1
<i>Installing the Master Measuring System</i>	1-2
<input type="checkbox"/> Selecting Location	1-2
<input type="checkbox"/> Proper Mounting	1-2
<input type="checkbox"/> Connecting Encoders	1-3
<input type="checkbox"/> Connecting Accessories	1-3
<input type="checkbox"/> Connecting Ground, Checking Voltage, Connecting Power	1-4
<i>Initial System Power-up</i>	1-4

Section 2. System Set-up

Set System Mode	2-1
<input type="checkbox"/> Setting Parameters	2-1
<input checked="" type="checkbox"/> <i>Entering Set System Mode</i>	2-1
<input type="checkbox"/> Quick Access Parameter Setting	2-1
<input checked="" type="checkbox"/> <i>Entering Quick Access Mode</i>	2-1
<input type="checkbox"/> Setting Axis Parameters	2-2
<input checked="" type="checkbox"/> <i>Save Changes</i>	2-2
<input checked="" type="checkbox"/> <i>Abandon Changes</i>	2-2

KEY: Entering Numeric Information	2-2
---	-----

<input type="checkbox"/> ENCRES Encoder resolution	2-2
<input type="checkbox"/> Choosing the Correct Resolution	2-2
<input checked="" type="checkbox"/> <i>Table of Metric Encoder Settings</i>	2-2
<input checked="" type="checkbox"/> <i>Making a Numeric Entry for English Scales</i>	2-2
<input type="checkbox"/> RAD-DIA Radius/Diameter Switching Enable.....	2-3
<input type="checkbox"/> Setting Radius/Diameter Switching	2-3
<input type="checkbox"/> LEC Linear Error Compensation	2-3
<input type="checkbox"/> Setting LEC with a Numeric Entry	2-3
<input type="checkbox"/> Setting LEC using Automatic Routine	2-3
<input checked="" type="checkbox"/> <i>Manual Edgefinder, same side surfaces</i>	2-3
<input checked="" type="checkbox"/> <i>Manual Edgefinder, opposite side surfaces</i>	2-4
<input type="checkbox"/> FACTOR Multiplier Factor	2-5
<input type="checkbox"/> Setting Multiplier Factor	2-5
<input type="checkbox"/> NEAR0 Near Zero Warning	2-5
<input type="checkbox"/> Quick Access Setup	2-6
<input type="checkbox"/> ENC DIR Encoder Counting Direction	2-6
<input type="checkbox"/> Setting Count Direction	2-6

<i>Option Parameters</i>	2-6
<input type="checkbox"/> Option Parameter Setting	2-6
<input type="checkbox"/> SLEEP Sleep Mode Operation	2-6
<input type="checkbox"/> Setting	2-6

Section 3. Master-G Readout Operations

DRO Operations	3-1
<input type="checkbox"/> Axis Display Settings	3-1
<input type="checkbox"/> Display Modes	3-1
<input checked="" type="checkbox"/> Absolute and Incremental	3-1
<input checked="" type="checkbox"/> Distance to Go	3-1
<input type="checkbox"/> Inch/Millimeter Measuring Units	3-1
<input type="checkbox"/> Display Resolution	3-2
<input type="checkbox"/> Zeroing Displays	3-2
<input checked="" type="checkbox"/> Absolute	3-2
<input checked="" type="checkbox"/> Incremental	3-2
<input checked="" type="checkbox"/> Distance-to-Go	3-2

Presetting Operations	3-3
<input type="checkbox"/> Entering Preset Mode	3-3
<input type="checkbox"/> Setting Absolute Preset Referencing a Datum Point (Absolute Zero)	3-3
<input type="checkbox"/> Setting Incremental Preset from Current Position	3-3
<input type="checkbox"/> Presetting Options	3-4

Power Loss Restoration Features	3-4
<input type="checkbox"/> Continu-Trac	3-4
<input type="checkbox"/> Recall	3-4
<input type="checkbox"/> Home Reference Point (HRP) Find Routine	3-4
<input checked="" type="checkbox"/> Setting HRP	3-4
<input type="checkbox"/> Finding LEC using an Electronic Edgefinder Probe	3-5

Section 4. Appendices

Appendix A. Troubleshooting	4-1
<input type="checkbox"/> No Operation	4-1
<input type="checkbox"/> Internal Testing	4-1
<input type="checkbox"/> Resetting Factory Defaults	4-2
<input type="checkbox"/> Error Reports	4-2
Appendix B. Master Readout Specifications	4-5
Appendix C. Encoder Requirements	4-6
Appendix D. Accessory Connectors and Output Specifications	4-7
<input type="checkbox"/> Edgefinder	4-7
<input type="checkbox"/> Remote Zero	4-7

Appendix E. Measurement Displays 4-8

Display Increments with Standard Encoder Resolution Selections 4-8

Appendix F. Warranty 4-9

FCC Compliance Statement 4-9

The ACU-RITE Warranty 4-9

30-day Red Carpet Warranty Service 4-10

Installation

Introduction

The family of Master readouts are application-specific, full-featured readouts that provide the measuring features required to obtain the most productivity from your manual machine tool.

- Master-MP® is a two- or three-axis application-specific readout designed especially for milling operations. It includes features to support common milling requirements such as creating hole patterns, and can be programmed to assist with producing multiple parts.
- Master-TP® is a two- or three-axis application-specific readout designed especially for turning operations. It includes features to support common turning requirements such as tool offsets, and can also be programmed to assist with producing multiple parts.
- Master-G® is a one-, two-, or three-axis general-purpose readout that provides the features required for most common machine tool operations. Programming features are not provided.

All Master readouts can be provided with options to allow coupling of two encoders onto one measurement axis, provide bi-directional RS232-C serial communications with a computer or output to a printer, provide connections to a parallel printer, provide a Control Function Interface (CFI) for simple machine control functions, and to provide a battery backup.

Accessories

Accessories are available to enhance your Master measuring system. They include:

- A Master Foot Switch for remote zeroing of selected axis displays
- An Edge Finder Probe to speed workpiece setup and measuring.

These accessories provide additional functions and capabilities to create a customized solution to your measuring system needs. To order these accessories, contact your ACU-RITE Distributor or Original Equipment Manufacturer/Importer (OEM/OEI), or call the ACU-RITE Sales and Service Center at (800) 344-2311.

Installing the Master Measuring System

IMPORTANT

BEFORE INSTALLING THE MASTER READOUT, RECORD THE SERIAL NUMBER ON THE WARRANTY CARD. THE SERIAL NUMBER LABEL IS LOCATED ON THE BOTTOM OF THE MASTER READOUT.

□ Selecting Location

Selecting a location for the Master readout is an important consideration for proper installation. Keep the following points in mind when selecting a safe and convenient location:

- The Master readout should be within easy reach of the operator for access to the keypad and other controls.
- The Master readout should be at approximate eye level and tilted towards the operator.
- Avoid moving components or tools, and minimize coolant splash or spray.
- The operating environment must be within the range of 0° to 40° C (32° to 104°F), with a non-condensing relative humidity of 25% to 95%.

□ Proper Mounting

ACU-RITE has developed special mounting kits for the Master readout which address the most common mounting requirements. Mounting kits include:

- Column and base machine mountings and floor stands
- Tray and yoke readout mounts
- Hardware and mounting instructions

These kits are available from your ACU-RITE Distributor, OEM/OEI, or the ACU-RITE Sales and Service Center at (800) 344-2311.

If fabricating a support device for the Master readout, it should be large and strong enough to accommodate the readout and any other devices that may be placed on top (printer, etc). It must also be stiff enough to minimize any vibration induced by machinery on the shop floor; vibration will make the displays difficult to read.

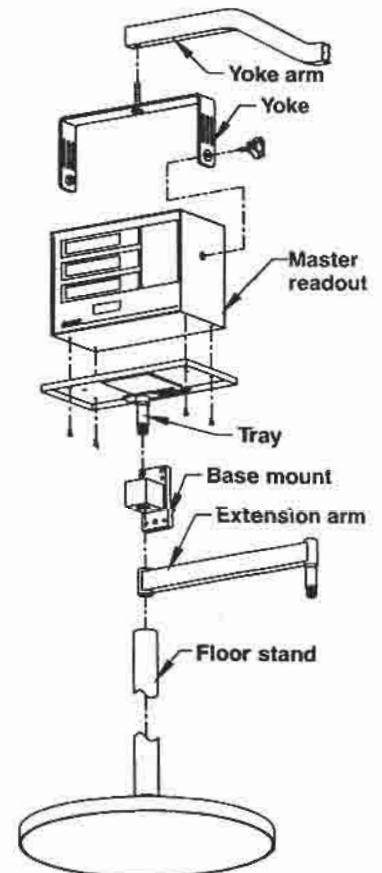
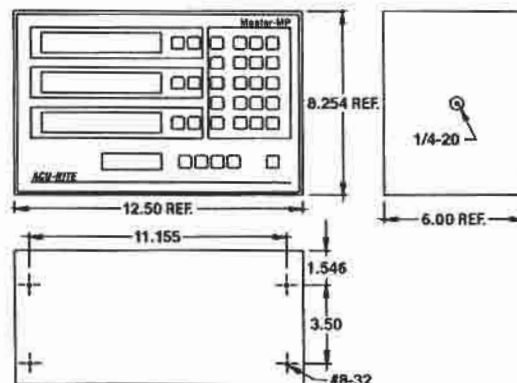

□ Connecting Encoders

Encoder input receptacles :

INPUT 1	X Axis
INPUT 2	Z1 Axis
INPUT 3	Z2 Axis

Insert the male connector from each encoder, with the large spline down, into mating receptacle on the back of the Master readout. Lock it in place with a 1/4-turn of the outer shell. If using encoders other than ACU-RITE's, refer to the connector requirements in Appendix C of Section 4. Appendices. Obtain the correct connector and install it on the encoder cables.

Provide enough slack in the encoder cables to allow for full travel of all machine axes. Assure that cables will not be pinched by table movements. Use the cable tie-down hardware kits supplied with the encoders to fasten the cables neatly to the machine.

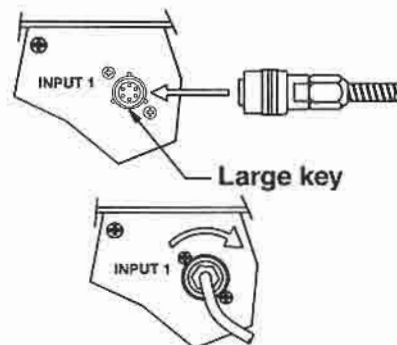

□ Connecting Accessories

Connect all accessories to the Master readout. Refer to Appendix D in Section 4. Appendices for a description of the ACU-RITE Foot Switch and Edge Finder Probe accessories and hookup information.

Each accessory should be mounted so that:

- Vibration, normal material handling, traffic near the installation site, and operation of the machine will not damage the accessory or cause it to fall.
- Power and signal cords are out of the way so they will not be damaged by machining operations or normal traffic, and are not a tripping hazard to the operator.
- Cords provide enough length to allow normal movements of the machine tables, the Master readout and its mountings, and other machine or mounting components.
- The accessories are within the view and easy reach of the operator.

□ **Connecting Ground, Checking Voltage, Connecting Power**

Connect a ground wire from the terminal on the back of the Master readout to the machine. The machine should also be connected to a solid earth ground.

Confirm the voltage available at the power source for connecting to the Master readout. Refer to Appendix B in Section 4. Appendices for a listing of the acceptable voltage ratings for use with the Master readout.

CAUTION

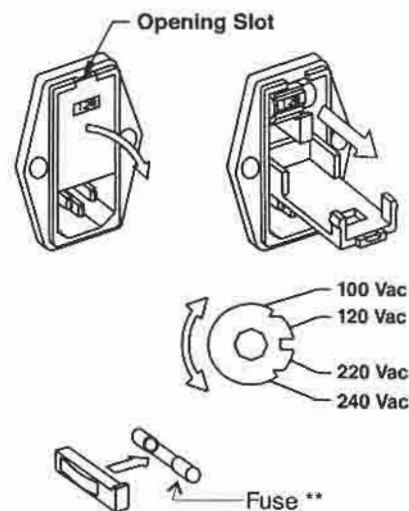

CONNECTING THE MASTER READOUT TO A POWER SOURCE OUTSIDE OF THE ACCEPTABLE RANGE OR MAKING AN INAPPROPRIATE SETTING WITH THE VOLTAGE SELECTOR OR USING AN INCORRECT FUSE MAY DAMAGE THE MASTER READOUT OR THE ENCODERS. THESE SITUATIONS CAN ALSO PRESENT A SAFETY HAZARD.

The voltage selector is set for 120VAC operation. If required, set the voltage selector to match the line voltage. Remove the caution label from the input module, and use a thin-bladed screwdriver in the slot at the top of the power input module to open the module cover. Pull the selection drum out, rotate it to the correct setting, and push it back into place. Close and snap the cover shut. The voltage setting will show through the window in the cover. Connect the Master readout to the power source using the power cord supplied.



** 100/120VAC: 1.0A, 250V, 3AG, slow-blow
 220/240VAC: 0.5A, 250V, 3AG, slow-blow

Initial system power-up

Press the  key on the front of the Master readout. The X-axis display flashes "E1", indicating that power to the readout has been interrupted. Press the  key. The Master readout commences digital readout (DRO) mode operations, with all displays zeroed.

Proceed to Section 2. System Set-Up for instructions on entering setup parameters.

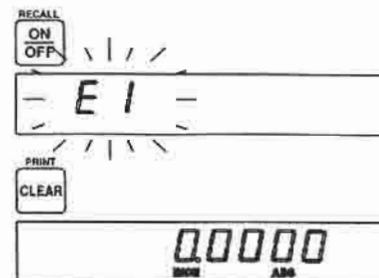

SYSTEM SET-UP

Set System Mode

Requires Access Code. Set when the readout is initially set-up and infrequently changed. Used to set all Axis Parameters.

Setting Parameters

■ **Entering Set System Mode:**

- Press SET SYS keys to start Setup
- Enter Access Code # _ _ _ _ found at the front of this manual. (This page may have been removed for safekeeping.)
- At display, Press axis key you wish to change. Ex:

The following parameters can be set for each axis:

<input type="text" value="Enc rES"/>	Encoder Resolution
<input type="text" value="rAd-d iA"/>	Radius/Diameter Switching Enable
<input type="text" value="LEc"/>	Linear Error Compensation
<input type="text" value="Enc d ir"/>	Encoder Count Direction
<input type="text" value="FRactor"/>	Multiplier Factor *
<input type="text" value="nERr 0"/>	Near-Zero Warning *

* Parameter may be set without entering code through Quick Access Setup

- Quick Access Parameter Setting** - can be used for Scaling Factor Multiplier, Near-Zero Warning and CFI option. These parameters may be changed often during machining. Quick Access does not require access code entry and locks system parameters out to prevent accidental changes.

- **To Enter Quick Access Mode:** Press SET SYS and Axis Key. Ex:

□ Setting Axis Parameters

- Press **ZERO** to display current parameter setting
- Pressing **ZERO** repeatedly toggles through parameter choices
- Pressing Axis key moves to the next parameter. Ex: **X**
- To set, or display, parameters on a new axis, Press desired axis key.

Ex: **Y** or **Z**

- **Save Changes:** Press **ON/OFF** to save settings and return to DRO mode.

- **Abandon Changes:** Press **2nd** **SET SYS** **ENTER** to return to DRO mode without changing setups.

Entering Numeric Information:

- Use minus key as required.
- If needed, clear incorrect entries by pressing **CLEAR**
- Last entry may be recalled by pressing **2nd** and axis key. Ex. **X**
- An axis may be de-selected by pressing the axis key again.
- More than one axis can be selected at a time for common numeric entry.

Enc RES

Encoder Resolution

Can be entered by choosing a table value or with a numeric entry.

- **Choosing the correct resolution** - from the list of available settings:

NOTE: CURRENT ACU-RITE ENCODERS ARE METRIC SCALES.

- *Use the following table to choose the correct metric encoder setting from the internal list in the readout:*

Setting (mm)		Resolution label
.01	=	10um (.0005")
.005	=	5um (.0002")
.002	=	2um (.0001")
.001	=	1um (.00005")

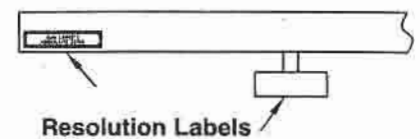

- Press **ZERO** for current setting
- Press **ZERO** again to toggle through available settings

- **To make a numeric entry for ACU-RITE English scales or non-ACU-RITE encoders:**

- Press **CLEAR** to zero out display
- If needed, Press **2nd** **INMM** **SET ABS** to set required measuring units. Enter numeric value.

NOTE: TO CLEAR AN INCORRECT ENTRY, PRESS **CLEAR**

r R d - d , R

Radius/Diameter Switching Enable

When an axis is set to enable the feature, the display will change between radius and diameter measurements when the RAD/DIA key is pressed..

Setting Radius / Diameter Parameter:

- Press **ZERO** for current setting at RAD/DIA prompt.
Settings can be either "DIA 0" to disable the RAD/DIA feature, or "DIA 1" to enable the feature
- Press **ZERO** again to change setting.

LE C

Linear Error Compensation

Can be entered with a numeric entry or by using the automatic routine.

Setting LEC with a numeric Entry:

- Press **ZERO** for current setting.
- Enter PPM (Parts Per Million) with numeric keypad.
- Press **ENTER** to record setting.

NOTE: THE SIGN IS IMPORTANT; USE THE **- KEY TO CHANGE THE SIGN OF THE COMPENSATION FACTOR. DIRECT ENTRY REQUIRES THAT THE LEC FACTOR BE DETERMINED MANUALLY. REFER TO SECTION 4, APPENDICES FOR INFORMATION ON HOW TO DETERMINE LEC FACTOR.**

Setting LEC using Automatic Routine

Requires either a manual or electronic Edge Finder Probe.

■ **Manual Edgefinder, same side surfaces (ex: dial indicator)**

1. Install a measurement standard of known length on the table, aligned with table movement.
2. Install edgefinder securely in the tool holder, or at another fixed reference position.
3. Press **ZERO** to display current setting.
4. Locate first edge of the standard,
Press **ZERO** again to zero the display.

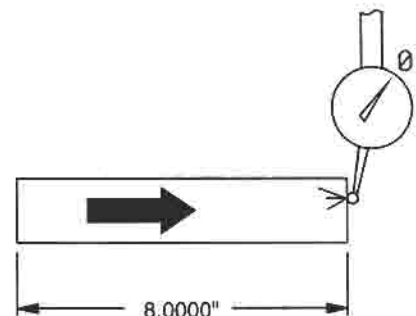

5. Move to the opposite end of the standard. As the example illustrates, use a firm, flat surface to create a marker at the end of the standard. Touch the end marker with the same side of the edge finder used to touch off the first edge. The axis display will show the distance moved (usually this value will be slightly different from the length of the standard). Press .

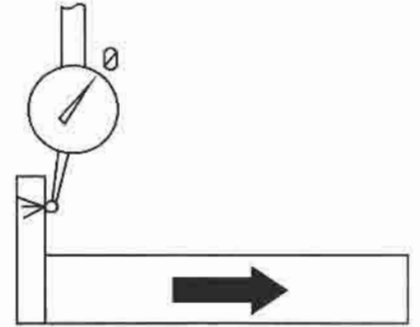

6. At Press
7. At Enter the length of the measuring standard,
Press - axis display will indicate calculated LEC factor in PPM.

PRESS TO SAVE SETTINGS

■ Manual Edgefinder, opposite side surfaces

1. Install a measurement standard of known length on the table, aligned with table movement.
2. Install edgefinder securely in the tool holder, or at another fixed reference position.
3. Press to display current setting.
4. Locate first edge of the standard,
Press again to zero the display.
5. Move to the opposite end of the standard.
Locate the second edge of the standard (usually the value will be slightly different from the length of the standard).

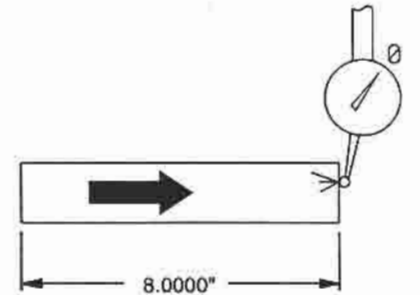

Press

6. At Enter the diameter of the edgefinder probe tip,
Press
7. At Enter the length of the measuring standard,
Press - axis display will indicate calculated LEC factor in PPM.

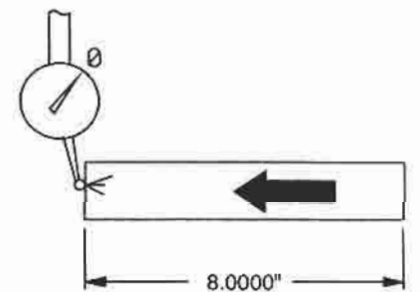

NOTE: E4 ERROR

E4 ERROR INDICATES THE CALCULATED LEC FACTOR IS OUTSIDE OF ACCEPTABLE RANGE OF -9999 TO +9999. TYPICALLY THE RESULT OF INCORRECT ENTRY DURING AUTOMATIC ROUTINE.

Press **ZERO** to re-start automatic routine at step 3.

- OR -

Press **CLEAR** to return to manual entry.

Factor

Workpiece Multiplier Factor

Can be set either in Axis Parameter Setup or Quick Access Setup.

Factory Default = 1.000000, or No scaling factor

Setting Multiplier Factor

- Press **ZERO** to view existing factor.
- Enter new value with numeric keypad.

Value > 1 ENLARGES features For example: setting multiplier factor to 2 will double the size of the part as compared to the engineering drawing.

Value < 1 SHRINKS features For example: setting multiplier factor to .5 will decrease the size of the part by 1/2, as compared to the engineering drawing.

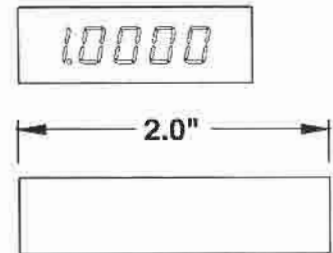

NOTE: ACCOMMODATING FOR MATERIAL SHRINKAGE. For a multiplier factor that reflects 3% part shrinkage, determine the scaling factor as follows:

$$\begin{aligned}
 \text{Scaling Factor} &= 1/(1-\text{shrinkage factor}) \\
 &= 1/(100\% - 3\%) \\
 &= 1/(0.970) \\
 &= 1.0309
 \end{aligned}$$

Mirror Imaging: A multiplier factor of -1.0 directly mirrors the dimensions entered. The multiplier factor may be set to other negative values to both mirror and scale the features.

near 0

Near Zero Warning

Can be set either in Axis Parameter Setup or Quick Access Setup.

Indicates that the tool is nearing zero. When the value of the axis display is within the near zero range set by the operator, the Near 0 annunciator (--> 0) on that axis will flash.

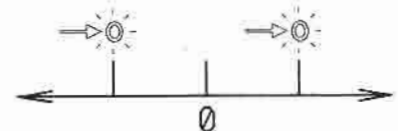

Quick Access Setup

In Quick Access Setup Mode:

- Press for the current Near 0 value.
- Enter new range with numeric keypad.

Encoder Counting Direction

Sets positive and negative count direction.

Factory Default = DIR 1

Setting Count Direction

- Press for current setting.
- Press again to change direction.

OPTION PARAMETERS

For RS-232, Multiple Scale Coupling (MSC) and Control Function Interface (CFI), refer to the Master Options manual.

- Option Parameter Setting** - refer to Master Options Manual.

Sleep Mode Operation

Installed on all Master Readouts. Will turn displays "off" after 30 minutes of no activity (indicated by a moving dot advancing across the X-axis display). Displays are "awakened" by pressing any key or moving an encoder.

Setting

- Press OPTION
- Press for current setting.
- Press again to toggle through available options:
 - 1 = Active
 - 0 = Not Active

MASTER READOUT OPERATIONS

DRO Operations

Axis Display Settings

Lighted annunciators on each axis indicate the current settings.

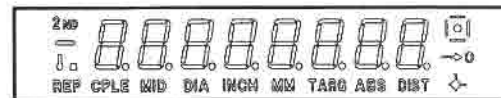

Display Modes

■ **Absolute and Incremental**

Absolute display shows the distance from your current position to Absolute Zero (Datum point/workpiece Zero).

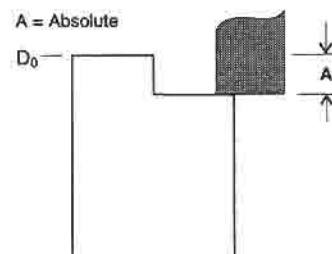

Incremental display shows the distance from your current position to your last incremental zero.

- Press to toggle through available choices.

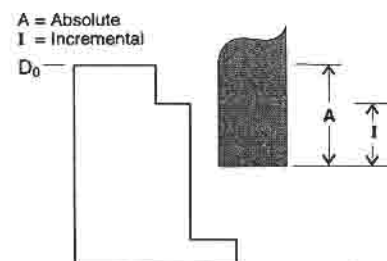

■ **Distance-to-Go**

Dist-to-Go shows the distance from your current position to your next preset dimension (target position).

- Press from any mode.

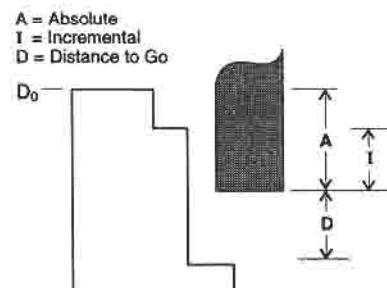

Inch/Millimeter Measuring Units

- Press to change current setting.

□ Display Resolution

Sets the display resolution as seen when the table is in motion. Resolution is available as High, Medium and Low. Refer to Appendix E in Section 4. Appendices, for a complete table of display options.

- Press to change the current setting.

Ex: A 2um (.0001") resolution linear encoder may be displayed as follows: .0001" / .0002" / .0005".

□ Zeroing Displays

■ *Absolute display*

The Datum Key is used to locate Absolute Zero or Workpiece Zero.

Setting Absolute Zero

- Locate edge of your workpiece.
- Press for each axis.

This sets the tools current position to Absolute Zero.

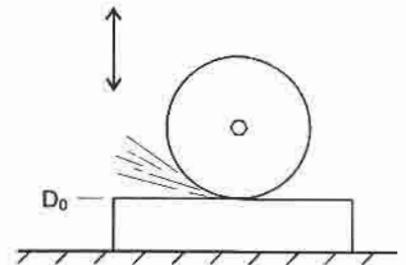

In the event of a Loss of Power, the Home Reference Point may be used to reestablish the position of Datum 0 without reindicating the workpiece (see Power Loss Restoration Features).

■ *Incremental display*

- Press if needed, to be in Incremental Mode, then Press on the appropriate axis.

■ *Distance-to-Go display*

- Press if needed, to be in Incremental Mode, then Press on the appropriate axis.

The Master-G readout may be used on a variety of general applications including surface grinders, cylindrical grinders, EDM equipment and others. The Presetting Operation will be described below for X / Y positioning on flat workpieces (ie. surface grinders).

NOTE: FOR EDM APPLICATIONS USING THE MASTER-G WITH CFI OPTION, SEE THE MASTER OPTION MANUAL

Presetting Operations

Distance-to-GO can be preset to indicate the distance to a targeted location. Target locations can be referenced from the current position (an incremental preset) or the Datum point (an absolute preset).

□ Entering Preset Mode

Press either **SET ABS** or **SET INCR**. Pressing either key will display the last preset values, and whether they were incremental or absolute, as shown by the display annunciators. Preset mode is indicated with a flashing "TARG" indicator.

□ Setting Absolute Preset Referencing the Datum Point (Absolute Zero)

- Press **SET ABS** **Y**
- Enter numeric value. Ex: [0.50"] = **•** **5**
- Press **X**
- Enter numeric value. Ex: [0.25"] = **•** **2** **5**
- Press **ENTER** Display shows the Distance-to-Go from your current position to the target position.
- Move until display shows zero.

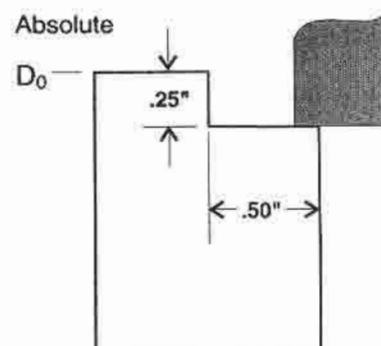

□ Setting Incremental Preset from Current Position

- Press **SET INCR** **Y**
- Enter numeric value. Ex: [0.25"] = **•** **2** **5**
- Press **X**
- Enter numeric value. Ex: [0.75"] = **•** **7** **5**
- Press **ENTER** Display will show the Distance to Go to the targeted position.
- Move until display shows zero.

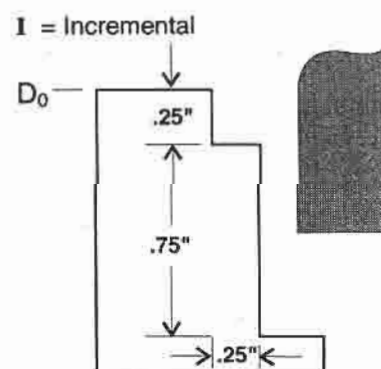

NOTE: FOR OPERATION OF THE MULTIPLE SCALING COUPLING OPTION WITH THE GRINDER'S WHEEL DRESSER, SEE THE MASTER OPTION MANUAL

Presetting Options

- To Re-use the previous preset entries for all axes, Press in Preset Mode.
- To Select another axis to preset, press the desired axis key. The previous axis is deselected.
- To Deselect an axis, press the axis key again. Display reverts to last preset value.

Power Loss Restoration Features

- Continu-Trac** - AC power is not lost, Press
- Recall** - AC power is lost, no table movements have been made, Press
- Home Reference Point (HRP) Find Routine**

The home reference point is a fixed reference mark along the machine table. It is found by sensing a reference signal on the encoder (the Fiducial Trigger Output signal, or FTO). FTOs are found every 8 inches (200 mm) on Mini-Scale and AR-5 Scales, and every 4 inches (100 mm) on MicroScales. Refer to your encoder manual for more information. Establishing a HRP creates the basis for referencing the position of Datum 0. After a loss of power, finding the HRP will allow you to return to your Datum 0 and restore all displays, DATUM locations and tool settings.

NOTE: THE HRP SHOULD BE ESTABLISHED EACH TIME A/C POWER IS TURNED OFF. THIS MUST BE DONE PRIOR TO SETTING DATUMS. IF DATUMS ARE ESTABLISHED WITHOUT FIRST SETTING THE HRP, THE READOUT SYSTEM CANNOT BE RETURNED TO DATUM 0 AFTER POWER LOSS.

IT IS VERY IMPORTANT TO LOCATE THE SAME REFERENCE POINT EACH TIME.

■ **Setting HRP**

- Determine workpiece location.
- Find closest encoder reference mark.
 - Press "REF" indicator will flash on all axes.
 - Select an axis by pressing the axis key. Ex:
- Move table for the selected axis in a positive direction until you move across the closest FTO. This is indicated when the "REF" indicator disappears.
- Mark FTO position on the scale case with a permanent marker.

At this point, the incremental displays will be zeroed, and the previous offset for the absolute display for DATUM 0 will be restored. A Home Reference Point offset will remain effective as long as AC power is not lost, regardless of whether or not the readout displays are ON or OFF.

NOTE: FOR COUPLED ENCODERS, SEE THE MASTER OPTIONS MANUAL.

□ **Finding Linear Error Compensation using an Electronic Edgefinder Probe**

1. Install a measurement standard of known length on the table, aligned with table movement.
2. Install Edgefinder securely in the tool holder.

3. Press

4. Enter the Access Code Number found at the front of this manual.

5. Prompt Press axis key you wish to change. Ex:

6. Press axis key until you receive Prompt

7. Press to activate edge finder.

Locate first edge of the measuring standard, axis display zeros at point of contact.

8. Move to the opposite end of the standard.

Press

Touch the end of the standard.

9. Prompt Enter the diameter of the Edgefinder. Ex:

10. Prompt

Enter the length of the measuring standard Ex:

Axis display will indicate calculated LEC factor in PPM.

Section 4. Appendices

Appendix A. Troubleshooting

This appendix covers some problems encountered with readout systems. Simple troubleshooting procedures are listed to assist service personnel with determining the extent of problems. If contacting your ACU-RITE Distributor, OEM/OEI, or the ACU-RITE Sales and Service Center for assistance, the service technician will need to know the results of these procedures.

No operation

If the Master readout display will not operate, check the following conditions:

- **Check outlet** If the Master readout cannot be turned on, confirm that line voltage is present at the outlet.
- **Check power at cord** Remove the power cord at the electrical input module on the back of the Master readout. Determine if line voltage is present at this end of the cord.
- **Check fuse** With the power cord removed, use a thin straight-blade screwdriver to remove the cover of the electrical input module. Slide out the fuse holder and check the fuse. If necessary, replace it.

CAUTION

REPLACE FUSES ONLY WITH THE SPECIFIED TYPE. USING INCORRECT FUSES CAN PRESENT A SAFETY HAZARD. THE MASTER READOUT MAY ALSO BE PERMANENTLY DAMAGED.

Use a 1.0A, 250V, 3AG, slow-blow style fuse (1-1/4" x 1/4" dia.) for 100/120VAC operation; or a 0.5A, 250V, 3AG, slow-blow fuse for 220/240VAC operation. Replace the fuse in the fuse holder, and slide it back into the input module. Replace the input module cover by snapping it back into place, and reconnect the power cord.

Internal testing

Several internal tests may be run to assure that the Master readout is functioning properly. Tests are available for the internal memory, the keypad, and the display. In addition, the testing procedure reports the version of the software programs built into the Master readout.

- **Begin the internal testing** from the OFF state by holding down the key while pressing the key. The software version is shown in the X-axis display.

- **Begin the memory test** by pressing the **X** key. After a short testing period, results are indicated in the X-axis display, as either "PASS" or "FAIL".
- **Begin keypad testing** by pressing the **X** key. Press each key (except the **X** key) in turn to verify that it is functioning properly. The X-axis display reports each key press by incrementing one digit starting with 0 and increasing to 9, then repeating.
- **Terminate keypad testing** and begin the display test by pressing the **X** key. All indicators in all displays are lit (including the auxiliary display for Master-MP and -TP readouts). Visually check each portion of each display to assure that they are functioning properly.
- **Return to the software version display** by pressing the **X** key. Repeat the tests as required.
- **Terminate the testing** at any time by pressing the **ON/OFF** key. The Master readout returns to the OFF state.

□ **Resetting factory defaults**

Master readouts can be reset to the factory defaults to allow more in-depth troubleshooting or to install the readout on another machine.

IMPORTANT

RESETTING THE MASTER READOUT TO FACTORY DEFAULTS WILL CLEAR ALL CURRENT SETTINGS. THIS INCLUDES THE CURRENT POSITION, ONGOING OPERATIONS, OPERATOR SETTINGS, AND ALL PARAMETERS.

- **Reset the Master readout** by turning the displays OFF with the **ON/OFF** key. Hold down the **X** ^{INMM} **SET ABS** **3** and **•** keys simultaneously. The X-axis display momentarily shows a "CLR MEM" message, confirming the reset.

□ **Error reports**

The Master readout includes built-in test and error-checking circuitry. This circuitry identifies errors that occur, and reports the problem to the operator.

System errors are reported to the operator with flashing error codes on the X-axis display, while axis errors are reported by flashing error codes in individual axis displays. Errors that are reported include loss of power, "E1"; counting (encoder signal miscount) errors, "E2"; display overflow (measurements too large to be displayed), "E4"; power-on memory error "E5"; programming error, "E6"; and memory test failure, "FAIL". Refer to Master Readout Operations for further details on resetting measurements to continue with machining operations following an error.

- **Loss of power** is indicated by a flashing "E1" error code in the X-axis display; all other displays are blank. Loss of power means that power to the Master readout has been interrupted. Since power to the encoders has also been interrupted, measuring information may no longer be accurate. Press the key to clear the error message. All display measurements are zeroed.
- **Counting errors** are indicated by a flashing "E2" error code in an axis display. Counting errors result from distorted electrical signals from an axis' encoder. These signals can be a result of an encoder malfunction, alignment or mounting problems, or electrical interference. Press the key to clear the error message. The axis display (for both absolute and incremental measurements) is zeroed.
- **Display overflow errors** are indicated by a flashing "E4" error code in an axis display. A numeric overflow occurs when the intended measurement is too large for the eight-digit display. Clear the error by returning the machine table into an area where measurements can again be displayed, selecting a lower display resolution, setting a new target preset, or zeroing the display with the key.

This error may also occur when using the automatic compensation routine while setting the LEC parameter. An error indicates that the calculated compensation factor was outside the acceptable range of -9999 to +9999, and usually is the result of incorrectly entering data. Clear the error and return to the beginning of the automatic error compensation routine by pressing the key.

- **Power-on memory errors** are indicated by a flashing "E5" error message in the X-axis display when the Master readout is turned on following a loss-of-power. An "E5" error denotes a serious internal failure, and indicates that some of the working settings are no longer valid. Working settings include current operating settings such as inches or millimeters; as well as programs, DATUMs, tool settings, current position information, and setup parameters.

Although all working settings can be checked and reset as required, they will likely be lost again when the power is interrupted. The Master readout should be serviced as soon as possible. Contact your ACU-RITE Distributor, OEM/OEI, or the ACU-RITE Sales and Service Center at (800) 344-2311.

Press the key to clear the error; an "E1" error will be displayed next, since power to the Master readout was interrupted. Press the key again to return to DRO operations.

CAUTION

SOME WORKING SETTINGS ARE NOT VALID. PROCEED WITH CAUTION.

Check all working settings before proceeding, and reset as required. Once reset, settings will be maintained until power to the Master readout is interrupted.

- **Program errors** are indicated by a flashing "E6" error code in the auxiliary display (Master-MP and -TP only). Error "E6" flags two related programming errors, either of which would result in a program or programs longer than 99 steps.

An "E6" error can occur when attempting to insert another step into a long program. With the INSERT STEP feature, all following program steps are pushed ahead by one step. The 99th step would be pushed ahead to become the 100th step, causing the error.

An "E6" error can also occur if the key is pressed when the current step is step 99. Since step 99 is the last available program step, attempting to move to the next step results in an error.

Press the key to clear the error and return to the current program step.

- **Memory failures** are indicated by a flashing "FAIL" error message in the X-axis display. A memory test failure indicates a serious malfunction with the Master readout.

CAUTION

THE MASTER READOUT CANNOT BE RELIED ON FOR CORRECT OPERATION IF A "FAIL" MESSAGE IS SHOWN DURING THIS TEST. The Master readout should be serviced immediately. Contact your ACU-RITE Distributor, OEM/OEI, or the ACU-RITE Sales and Service Center at (800) 344-2311.

The error message can be cleared with the key, and further testing or operations can be resumed.

Appendix C. Encoder Requirements

Table 4-2. Master encoder receptacle pin-out

Pin	Signal
A	Channel A square wave counting signal
B	Channel B square wave counting signal in quadrature (90° nominal phase relationship) with channel A signal
C	Vcc, +5.1 +/-0.1 VDC @ 140 mA (supplied by Master readout)
D	Common (power supply and signal return)
E	Shield, reading head casting ground
F	Fiducial Trigger Output (FTO) signal

If installing a non- ACU-RITE encoder, a connector kit may be obtained to adapt the encoder cable for use with the Master readout. Contact your ACU-RITE Distributor or OEM/OEI, or the ACU-RITE Sales and Service Center at (800) 344-2311, and order part number 382214-000.

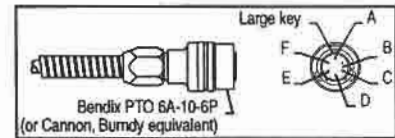

Figure 4-1. Required encoder connector

Table 4-3. Master encoder receptacle pin-out

Characteristic	Requirement
Output signals Incremental	Two square-wave signals, channels A and B, In quadrature (90° nominal phase relationship)
FTO	One square-wave signal
Signal levels	Low: 0 to 0.8 VDC High: 3.5 to 5.1 VDC
Maximum current draw	140 mA
Minimum A to B channel edge separation	5 us

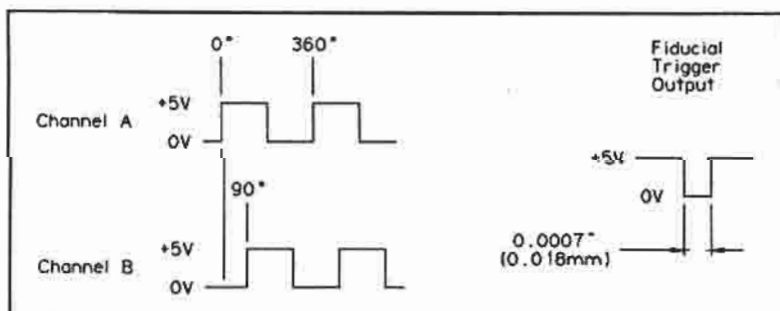

Figure 4-2. Typical encoder waveforms

Appendix D. Accessory Connectors and Output Specifications

All Master readouts are equipped with receptacles for the ACU-RITE VISION/Master Edgefinder Probe and ACU-RITE Master Foot Switch accessories

EdgeFinder

The EDGEFINDER receptacle is provided for use with the ACU-RITE VISION/Master Edge Finder Probe accessory. The accessory is equipped with a cable that provides a mating connector.

Other manufacturer's edge finder probes may be used, if they perform the same functions as the ACU-RITE unit, and can be provided with a comparable connector. The connector from the edge finder must be a two-conductor, 1/8" (3.5mm) Mini-size Phone plug, such as Radio Shack part number 274-288. The ball or contact edge must be electrically isolated from the tool holder and the machine base. The conductor from the edge finder must be wired to the central contact on the plug, and the other conductor from the workpiece or machine base must be wired to the side contact on the plug.

Remote Zero

The REMOTE ZERO receptacle is provided for use with the ACU-RITE Master Foot Switch Assembly accessory. The Foot Switch can be used in place of the ZERO key to zero a selected Master axis display.

Prior to installing the accessory, the connector supplied with the Foot Switch must be installed on the cable and wired to zero the desired axis. Refer to Table 4-5. for wiring information. For example, if the Foot Switch is to be used to zero the X-axis display, connect one wire on the Foot Switch cable assembly to pin 5, and the other wire to pin 1, 2, or 7.

Other switch arrangements may be used, if they perform the same functions as the ACU-RITE Foot Switch Assembly. Up to three switches may be provided for this assembly, one for each axis that is to be zeroed remotely. Each external switch must be a normally-open, momentary-closed, SPST switch. One side of each switch must be wired to one of the remote axis-zeroing connector pins (4, 5, or 6), and the other side wired to one of the ground pins (1, 2, or 7). The connector from the switch(es) must be an eight-conductor DIN plug, such as Switch Craft part #15BL7M.

Table 4-5. Remote zero receptacle pin-out

Pin	Signal
1	Ground
2	Ground
3	N.C.
4	Remote zero, Y- (Z1-) axis
5	Remote zero, X-axis
6	Remote zero, Z- (Z2-) axis
7	Ground
8	N.C.

Appendix E. Measurement displays

□ Display increments with standard encoder resolution selections

The DISP RES feature allows setting display resolution to high resolution, medium, or low resolution. Table 4-6. shows the least-significant digit and number of decimal digits displayed, with each selection of encoder resolution provided by the Master readout. The table shows these characteristics for all combinations of inches vs. millimeter and radius vs. diameter (Master-G only) settings.

Table 4-6. Master display increments with various settings

Encoder Resolution	INCH, RAD			INCH, DIA			MM, RAD			MM, DIA		
	High	Medium	Low	High	Medium	Low	High	Medium	Low	High	Medium	Low
10 μ m	0.0005	0.001	0.002	0.001	0.002	0.005	0.01	0.02	0.05	0.02	0.05	0.1
5 μ m	0.0002	0.0005	0.001	0.0005	0.001	0.002	0.005	0.01	0.02	0.01	0.02	0.05
2 μ m	0.0001	0.0002	0.0005	0.0002	0.0005	0.001	0.002	0.005	0.01	0.005	0.01	0.02
1 μ m	0.0005	0.0001	0.0002	0.0001	0.0002	0.0005	0.001	0.002	0.005	0.002	0.005	0.01
0.0005"	0.0005	0.001	0.002	0.001	0.002	0.005	0.02	0.05	0.1	0.05	0.1	0.2
0.00025"	0.0005	0.0005	0.001	0.0005	0.001	0.002	0.01	0.02	0.05	0.02	0.05	0.1
0.0001"	0.0001	0.0002	0.0005	0.0002	0.0005	0.001	0.002	0.005	0.01	0.005	0.01	0.02

1. The table illustrates Master display increments with various combinations of INCH/MM and RAD/DIA key settings.
2. The display increments corresponding to a diameter setting are valid only if diameter displays are enabled on that axis.

Appendix F. Warranty

FCC compliance statement

This equipment generates, uses, and can radiate radio frequency energy and if not installed and used in accordance with the instructions in this manual, may cause interference to radio communications. It has been tested and found to comply with the limits in effect at the time of manufacture for a Class A computing device pursuant to Subpart J of Part 15 of FCC Rules, which are designed to provide reasonable protection against such interference when operated in a commercial environment. Operation of this equipment in a residential area is likely to cause interference in which case the user at his own expense will be required to take whatever measures may be required to correct the interference.

The ACU-RITE warranty

ACU-RITE products and accessories are warranted against defects in material and workmanship for a period of three years from the date of purchase. ACU-RITE will, at its option and expense, repair or replace any part of the ACU-RITE product which fails to meet this warranty. This warranty covers both materials and factory service labor. In addition, ACU-RITE Distributors and OEM/OEI service representatives will provide service labor (field service) for a one-year period at no charge. Notice of the claimed defect must be received by ACU-RITE within the warranty period.

This warranty applies only to products and accessories installed and operated in accordance with this reference manual. ACU-RITE shall have no obligation, with respect to any defect or other condition caused in whole or in part by the customer's incorrect use, improper maintenance, modification of the equipment, or by the repair or maintenance of the product by any person except persons deemed by ACU-RITE to be qualified.

Responsibility for loss in operation performance due to environmental condition, such as humidity, dust, corrosive chemicals, depositions of oil or other foreign matter, spillage, or other conditions beyond ACU-RITE's control cannot be accepted by ACU-RITE.

There are no other warranties expressed or implied, and ACU-RITE INCORPORATED shall not be liable under any circumstances for consequential damages.

- 30-day Red Carpet Warranty Service**

IMPORTANT

KEEP THE BOX AND PACKING MATERIALS.

Your ACU-RITE Master readout is covered by a 30-day Red Carpet Warranty Service. If in the first 30 days this product fails for any reason, repack it in the original packing materials and contact your ACU-RITE Distributor, OEM/OEI, or the ACU-RITE Sales and Service Center at (800) 344-2311 for return instructions.

For future ordering information or warranty service, record the following information:

Master readout serial number (located on bottom of unit): _____

Software version (from internal tests): _____

Encoder catalog and serial numbers:

X-axis: _____

Y- (Z_1 -) axis: _____

Z- (Z_2 -) axis: _____

Date of purchase: _____

Distributor: _____

Address: _____

Telephone: _____



ACU-RITE Readout Systems
are manufactured in the USA



ACU-RITE®

ONE PRECISION WAY
MASON INDUSTRIAL PARK
JAMESTOWN, NEW YORK 14701
(800) 344-2311

