

ACU-RITE



Digital Readouts

Linear Encoders

For Manually Operated
Machine Tools

August 2016

Digital readouts from ACU-RITE make your manually operated machine tools more profitable, improve productivity and raise the quality of the machined workpiece. The large LCD display clearly shows the actual axis positions. The context-sensitive graphical user guidance makes working with digital readouts from ACU-RITE a pleasure.

Together with the linear scales from ACU-RITE they form an economic and effective package solution for initial setup or retrofitting on your machine tool.





Contents

| | | |
|------------------------------|--|-----------|
| Digital readouts | | |
| Overview | | 4 |
| Functions | Probing functions for datums (200S, 300S) | 6 |
| | Tool compensation (VUE, 200S, 300S) | 6 |
| | Distance-to-go display (VUE, 200S, 300S) | 7 |
| | Contour monitoring (VUE, 300S) | 7 |
| | Hole patterns (VUE, 200S, 300S) | 8 |
| | Programming of machine steps (300S) | 8 |
| | Help for working with lathes (VUE, 200S, 300S) | 9 |
| Specifications | VUE – Simple position display for two and three axes | 10 |
| | 200S – Flexible digital readout for two and three axes | 12 |
| | 300S – The programmable readout for up to four axes | 14 |
| Accessories | Edge finder | 16 |
| | Mounting components | 17 |
| | IOB 49 external input/output unit | 20 |
| Interfaces | | 22 |
| Linear encoders | | |
| Overview | | 24 |
| Mounting instructions | | 25 |
| Specifications | SENC 50 – Compact linear encoder for limited installation space | 26 |
| | SENC 150 – Standard linear encoder | 28 |
| Interfaces | Incremental signals □ □ TTL | 30 |
| Electrical connection | Cable | 31 |
| | General electrical information | 31 |

Selection guide

| | Number of axes | Reference points/ Tool data | Functions |
|---|----------------|--------------------------------|---|
| VUE Digital readout for milling, drilling and boring machines, as well as lathes, with one, two or three axes <ul style="list-style-type: none"> • Monochrome screen • Membrane keyboard | 1, 2 or 3 | 10 datums; 16 tools | <i>General:</i> <ul style="list-style-type: none"> • Distance-to-go display with graphic positioning aid <i>Milling and drilling:</i> <ul style="list-style-type: none"> • Tool radius compensation • Hole patterns (circular and linear patterns) • Inclined or arc milling <i>Turning:</i> <ul style="list-style-type: none"> • Taper calculator • Radius/Diameter display • Separate and sum display |
| 200S Digital readout for milling, drilling and boring machines, as well as lathes, with two or three axes <ul style="list-style-type: none"> • Monochrome screen • Splash-proof full-travel keyboard • Switching inputs/outputs (via IOB 49) | 2 or 3 | 10 datums; 16 tools | <i>General:</i> <ul style="list-style-type: none"> • Distance-to-go display with graphic positioning aid <i>Milling and drilling:</i> <ul style="list-style-type: none"> • Probing functions for KT edge finder • Tool radius compensation • Hole patterns (circular and linear patterns) • Inclined or arc milling <i>Turning:</i> <ul style="list-style-type: none"> • Radius/Diameter display • Separate and sum display |
| 300S Digital readout for milling, drilling and boring machines with up to four axes as well as for lathes <ul style="list-style-type: none"> • Color screen • Program memory • Splash-proof full-travel keyboard • Switching inputs/outputs (via IOB 49) | Up to 4 | 10 datums; 99 tools | <i>General:</i> <ul style="list-style-type: none"> • Distance-to-go display with graphic positioning aid • Program memory for up to 8 programs with 250 steps each <i>Milling and drilling:</i> <ul style="list-style-type: none"> • Probing functions for KT edge finder • Tool radius compensation • Hole patterns (circular and linear patterns) • Inclined or arc milling <i>Turning:</i> <ul style="list-style-type: none"> • Taper calculator • Radius/Diameter display • Separate and sum display |



| Encoder inputs | Switching inputs/ outputs | Data interface | Model | Page |
|--|-------------------------------------|----------------|-------|------|
|  | - | USB | VUE | 10 |
|  | For KT edge finder; more via IOB 49 | RS-232-C/V24 | 200S | 12 |
|  | For KT edge finder; more via IOB 49 | RS-232-C/V24 | 300S | 14 |

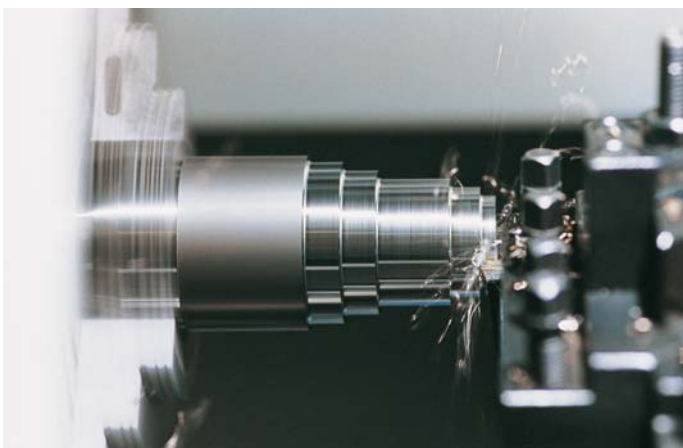
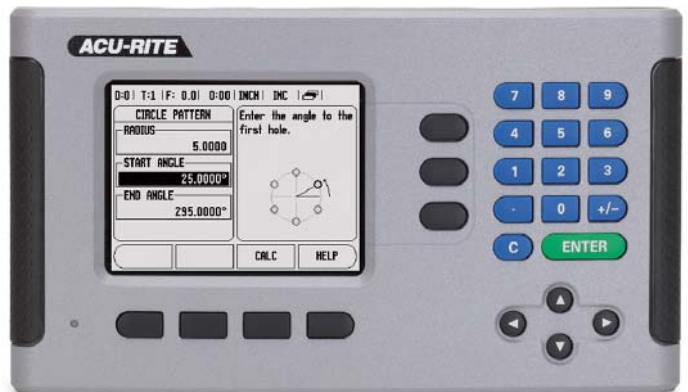

Functions

- Probing functions for datums (200S, 300S)
- Tool compensation (VUE, 200S, 300S)

Easy setup with probing functions

A very useful accessory for datum setting is the HEIDENHAIN KT edge finder. Simply move the edge finder toward a side of the workpiece until the stylus deflects. The counter automatically stores the exact position, taking into account the direction of approach and the radius of the stylus. In milling machine mode, the 200S and 300S digital readouts offer the following probe functions:

- Workpiece edge as reference line
- Workpiece centerline as reference line
- Circle center as datum

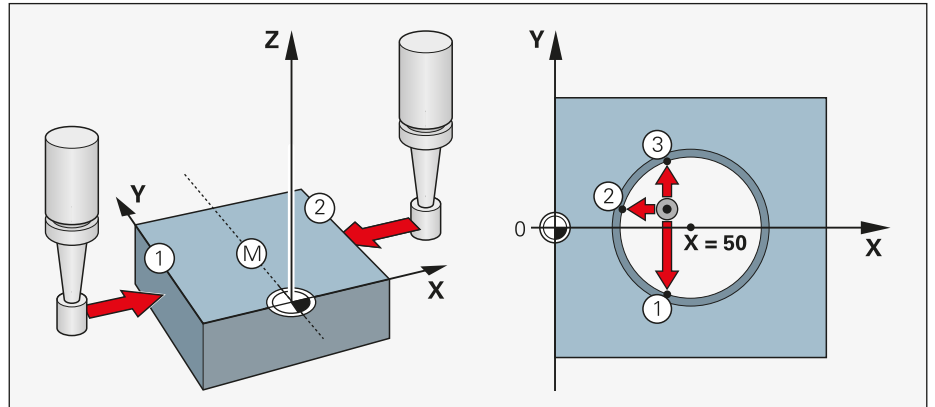

Convenient datum setting with an edge finder

For electrically conductive workpieces, these functions are also possible with an edge finder with contact triggering to ground.

Datum finding with the tool

The probe functions can also be performed with the tool.

Tool compensation for milling machines

The ACU-RITE digital readouts save tool data in a tool table, i.e. diameter and length of the tool used. The data can come from preset tool or be measured on the machine.

When positioning in distance-to-go mode, the readouts take the tool radius ($R+$ or $R-$) in the machining plane into account and consider the tool length (ΔL) in the spindle axis.

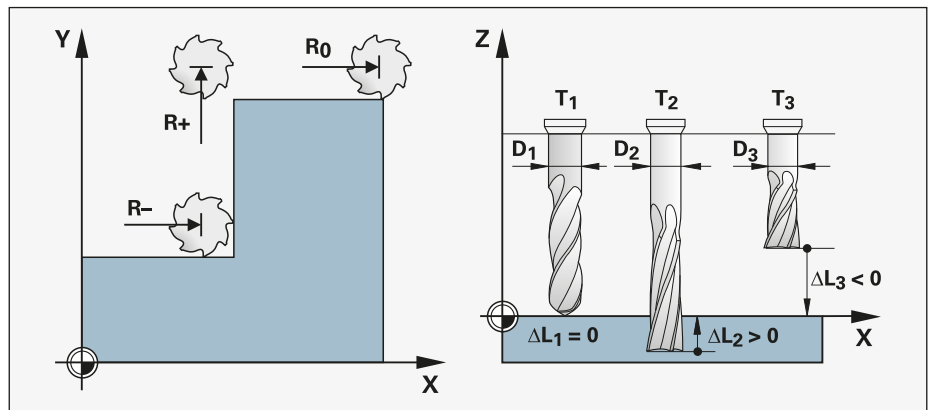

Compensation of tool radius and length

Determining and storing tool compensation values on lathes

You can store the data for the tools you insert in the turret or quick-change holder in the tool table:

- Enter the tool position directly when turning the first diameter, or
- "freeze" the current axis position value, retract the tool, measure the turned diameter and then enter that value.

Changing datums

If you change the workpiece or the workpiece datum, you can fix the new datum without having to change the stored tool-offset values. The tool data are automatically referenced to the new datum.

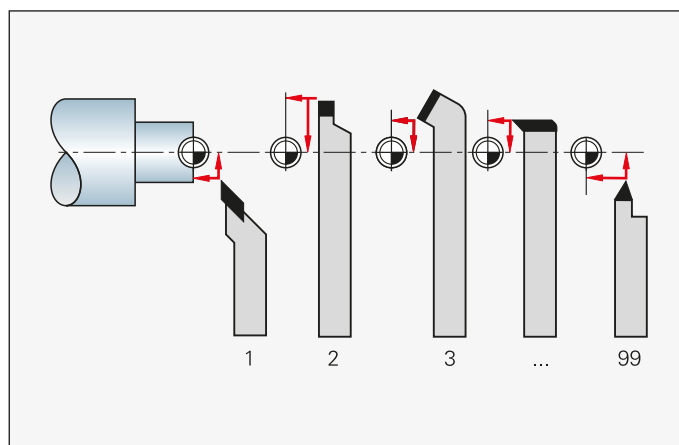

- Distance-to-go display (VUE, 200S, 300S)
- Contour monitoring (VUE, 300S)

Distance-to-go display for turning and milling

The distance-to-go display feature simplifies your work considerably: you enter the next nominal position, and the display shows you the distance remaining to the target position. This means that you simply move to the display value zero.

The displays for milling can also compensate the cutter radius. In this way you can directly use the drawing dimensions without having to do any conversions. You no longer have to remember any complicated values.

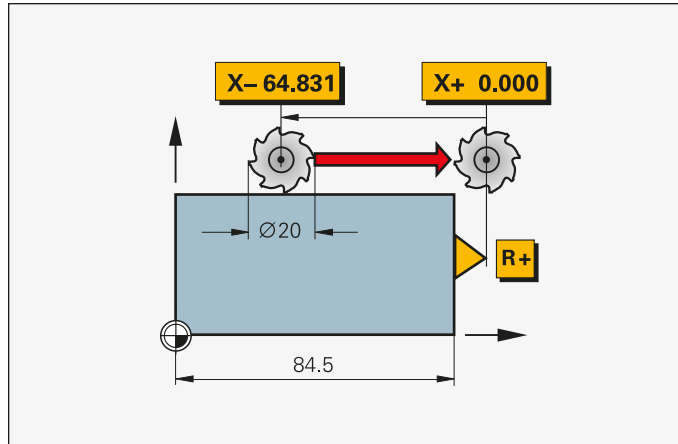

The distance-to-go display is enhanced by a "near zero" message: As you traverse to zero, a square cursor moves into a target fork. The "near zero" message is configurable per axis.

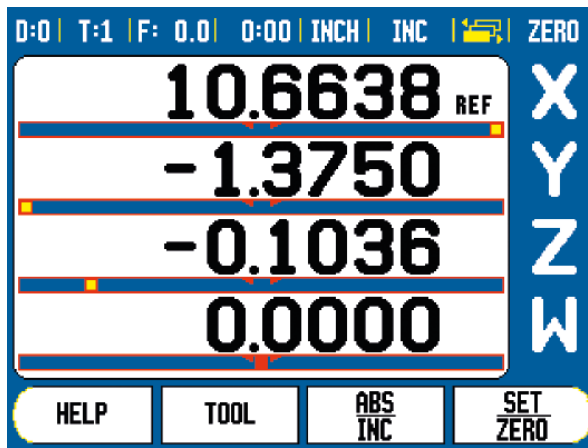

300S,VUE: Contour monitoring for overseeing manual 2-D operations

Special functions enable you to run 2-D milling and turning operations with a manual machine. The contour monitoring function shows you whether you are moving the tool near to the defined contour.



Functions

- Hole patterns (VUE, 200S, 300S)
- Programming of machine steps (300S)

Automatic calculation of bolt hole patterns for milling and drilling

In milling machine mode you can machine **bolt hole circles** (full circle or circle segments) and **linear hole patterns** without having to calculate:

You simply enter the geometric dimensions and the number of holes from the drawing. The display calculates the coordinates of the individual holes in the working plane. You only need to traverse "to zero" and drill. Then the display shows the next position. The **graphic display** is a particularly useful feature: it lets you verify your input for the programmed bolt-hole pattern before machining.

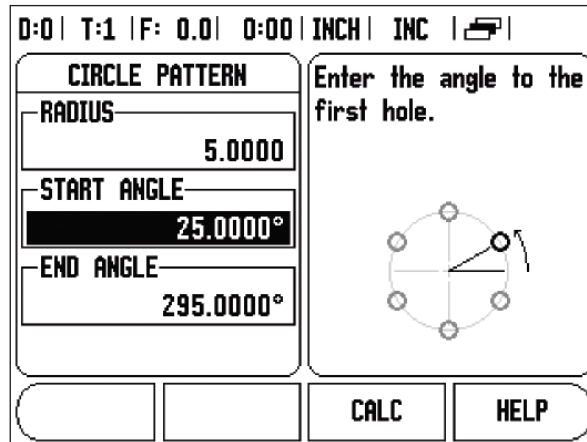

Programming machining steps

300S programming functions allow you to save repetitive machining steps. Thus for example you can save all of the machining steps required as a program for a workpiece in a small-batch. In the RUN mode of operation, the distance-to-go display will guide you step-by-step to the programmed positions.

You create programs by typing in the positions step by step. The fixed cycles such as Bolt Hole Circle, Linear Hole Pattern, Incline Mill Form or Circular Arc keep your programs short and save you programming time. In the course of your work, the readout presents each nominal position in the proper sequence. You need only move from one position to the next.

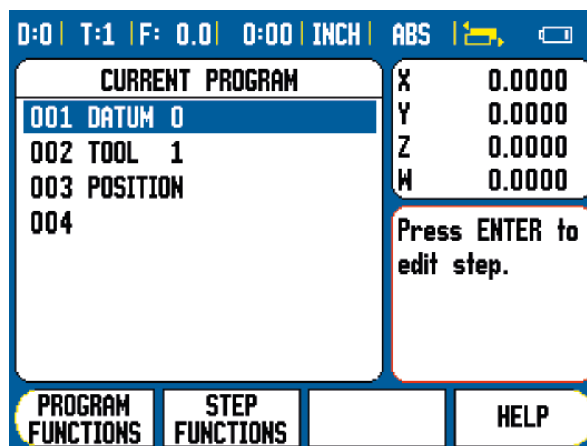

– Help for working with lathes (VUE, 200S, 300S)

Radius/diameter display

In the lathe mode, you can see the positions of the transverse axis in either radius or diameter values. You can switch at a keystroke.

Sum display of longitudinal axes

In lathe mode, the positions of the saddle and the top slide are displayed either separately or as the sum of both values.

- If you select **separate displays**, the position values are referenced to the datum for each individual axis. If only the saddle is moved, the displayed value for the top-slide axis remains unchanged.
- If **sum display** is selected, the counter adds both values while taking the algebraic sign into account. You can now read the absolute position of the tool in relation to the workpiece datum—without having to calculate!
- **Vectoring**

The vectoring function breaks down the movement of the compound axis into the crossfeed or longitudinal axes. If you are turning threads, for example, vectoring lets you see the diameter of the thread in the X-axis display, even though you are moving the cutting tool with the compound axis handwheel.

Taper turning made easy

If taper dimensions do not include the angle, the integrated taper calculator will help you with the calculation. Simply enter the taper ratio or the two diameters and the length. The correct angle for the top slide will be displayed immediately.

Constant surface speed

Particularly in taper turning or parting, the surface speed usually changes along with the diameter. But a constant surface speed is better for optimum machining results and long tool life. The 300S and 200S digital readout in conjunction with the output module IOB 49 therefore makes it possible to control workpiece rotation to ensure a constant surface cutting speed in spite of a changing workpiece diameter.

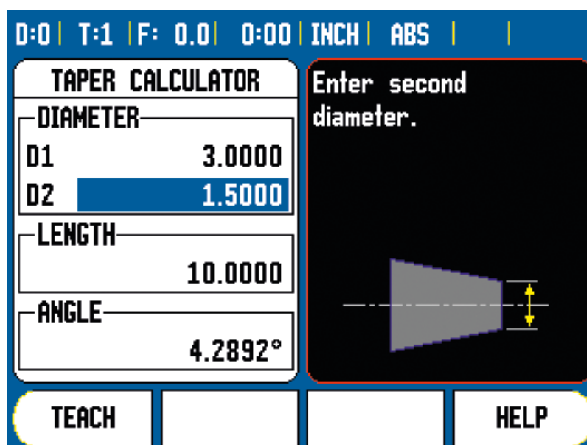
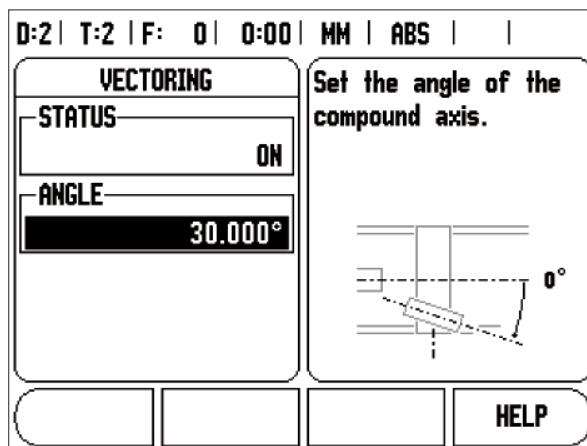
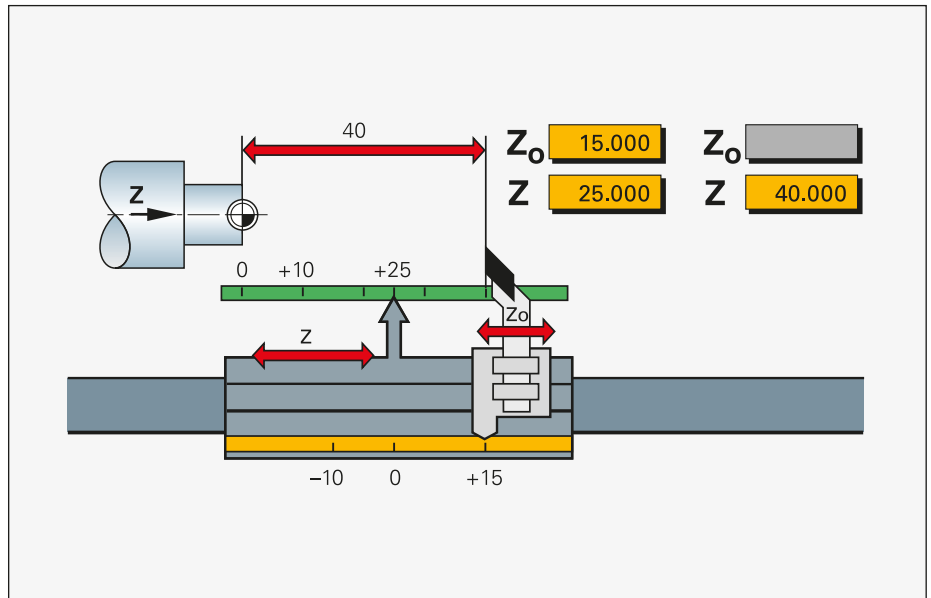

Calculation of the taper angle (e.g. 300S)

VUE

– Simple digital readout one for two or three axes

The VUE position displays from ACU-RITE are suited for use on manually operated milling, drilling, boring machines and lathes with two or three axes.

Execution

With its sturdy housing and splash-proof membrane keyboard, the VUE is built for the workshop. The VUE shows display position values, the soft-key row and other useful information on a monochrome graphic screen.

Functions

The most important functions are available quickly and directly via function keys. Soft keys with clear information in the local language enable you to make entries that fit your momentary situation.

The **distance-to-go display** facilitates positioning tasks. You approach the next position quickly and reliably by simply moving until the display reads zero. The functions for each application are easily activated by parameter input. Special functions are available for producing **hole patterns** (linear patterns and circular patterns).

You can easily switch between radius and diameter display when the position display is configured for turning. For lathes with a separate top slide, the **sum display** feature on the 3-axis version of the VUE allows you to display the saddle and top slides together or separately. Setting datums on a lathe part is particularly easy with the **freeze tool position** function and subsequent retracting.

Data interfaces

A USB interface enables the digital readout to transfer measured values and import or export parameters and tables.

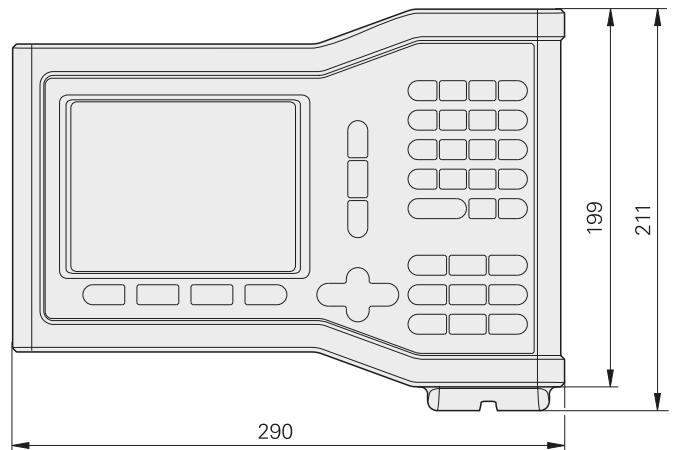
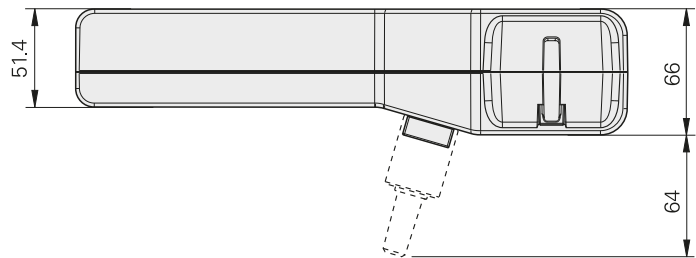

mm

 Tolerancing ISO 8015
 ISO 2768 - m H
 < 6 mm: ±0.2 mm

| | VUE |
|----------------------------------|---|
| Axes* | 1, 2 or 3 from A to Z and Z ₀ |
| Encoder inputs | □□ TTL |
| Display step¹⁾ | Adjustable, max. 7 digits <i>Linear axis:</i> 1 mm to 0.0001 mm <i>Angular axis:</i> 1° bis 0,001° (00° 00' 01") |
| Display | 5.7" monochrome flat-panel display for position values, dialogs and inputs, and soft keys |
| Status display | Tool, reference point, operating function, feed rate, ABS/INC, mm/inch, stopwatch |
| Functions | <ul style="list-style-type: none"> • 10 reference points • 16 tools • REF reference-mark evaluation for distance-coded or single reference marks • Distance-to-go mode • Scaling factor • mm/inch switching • Absolute-incremental display • On-screen help and operating instructions • Graphic positioning aid ("near zero" warning) • Calculator |
| For milling/drilling/boring | <ul style="list-style-type: none"> • Calculation of positions for hole patterns (bolt circles, linear hole patterns) • Tool radius and tool length compensation • Probing functions for reference-point acquisition with KT edge finder: "Edge," "Centerline" and "Circle center" • Oblique line, circular arc • Linear hole patterns, bolt hole circles |
| For turning | <ul style="list-style-type: none"> • Taper calculator • Radius/diameter switching • Freezing the tool position for back-off • Vectoring: XY display of the traverse path with inclined top slide • Sum display for Z and Z₀ (axis coupling) |
| Error compensation | <ul style="list-style-type: none"> • <i>Axis error:</i> Linear and multipoint over up to 200 points • <i>Backlash compensation:</i> for compensation of reversal error |
| Data interface | USB (type B connector), up to 115 200 baud |
| Accessories | Base, mounting arms, mounting frame |
| Power connector | AC 100 V to 240 V (-15 % to +10 %), 47 Hz to 63 Hz; 54 W |
| Operating temperature | 0 °C to 45 °C (storage temperature -20 °C to 70 °C) |
| Protection EN 60529 | IP 40, front panel IP 54 |
| Mass | 2.6 kg |

* Please select when ordering

¹⁾ Depends on the signal period of the connected encoder

200S

– Flexible digital readout for two or three axes

The ACU-RITE 200S digital readout is especially suited for use on milling, drilling and boring machines and lathes with up to three axes. A separate I/O unit provides switching input/outputs for simple tasks in automation.

Design

The 200S display unit is designed as a sturdy upright unit with splash-proof full-travel keypad for use in a workshop. It is equipped with a monochrome flat screen for position values, dialog and input displays, graphic functions and graphic positioning support.

Functions

The 200S display unit is characterized by its plain language dialog guidance. The **distance-to-go display** facilitates positioning tasks. You approach the next position quickly and reliably by simply moving until the display reads zero. The functions for each application are easily activated by parameter input. Special functions are available for producing **hole patterns** (linear patterns and circular patterns). Datums can be determined quickly and accurately with an edge finder. The 200S readout supports you with special **probing functions**.

You can easily switch between radius and diameter display when the position display is configured for turning. The readout also offers support for lathes with separate top slide: The **sum display** feature allows you to display the saddle and top slides together or separately. To set a datum, simply touch the workpiece and **freeze the tool position**. Then retract and measure workpiece with the tool out of the way.

Data interfaces

The 200S features an RS-232-C/V.24 serial interface for measured value transfer to a PC or printer, for input/output of parameters and compensation value lists, and for diagnostics.

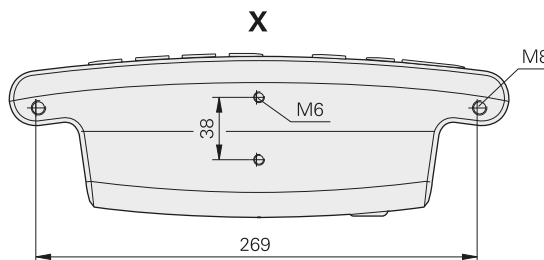
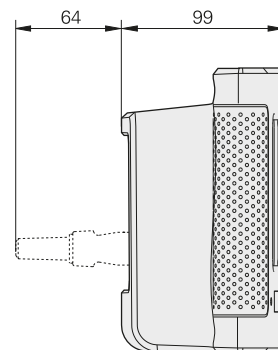
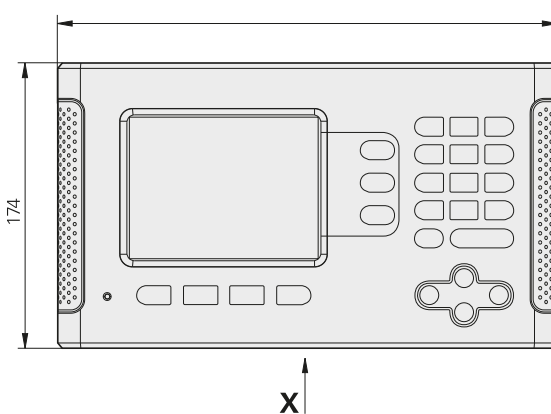
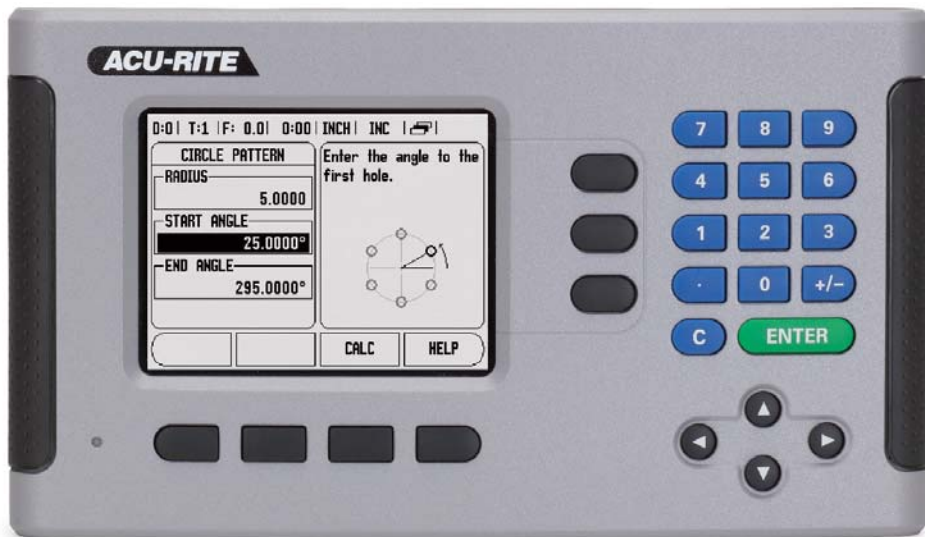

mm

 Tolerancing ISO 8015
 ISO 2768 - m H
 < 6 mm: ±0.2 mm

| | 200S |
|----------------------------------|---|
| Axes* | 2 or 3 from A to Z and Z ₀ |
| Encoder inputs | □□ TTL |
| Display step¹⁾ | Adjustable, max. 7 digits <i>Linear axis:</i> 1 mm to 0.0001 mm <i>Angular axis:</i> 1° bis 0,001° (00° 00' 01") |
| Display | 5.7" monochrome flat-panel display for position values, dialogs and inputs, and soft keys |
| Status display | Tool, reference point, operating function, feed rate, ABS/INC, mm/inch, stopwatch |
| Functions | <ul style="list-style-type: none"> • 10 reference points • 16 tools • REF reference-mark evaluation for distance-coded or single reference marks • Distance-to-go mode • Scaling factor • mm/inch switching • Absolute-incremental display • On-screen help and operating instructions • Graphic positioning aid ("near zero" warning) • Calculator |
| For milling/drilling/boring | <ul style="list-style-type: none"> • Calculation of positions for hole patterns (bolt circles, linear hole patterns) • Tool radius and tool length compensation • Probing functions for reference-point acquisition with KT edge finder: "Edge," "Centerline" and "Circle center" • Linear hole patterns, bolt hole circles |
| For turning | <ul style="list-style-type: none"> • Taper calculator • Radius/diameter switching • Freezing the tool position for back-off • Vectoring: XY display of the traverse path with inclined top slide • Sum display for Z and Z₀ (axis coupling) |
| Error compensation | <ul style="list-style-type: none"> • <i>Axis error:</i> Linear and multipoint over up to 200 points • <i>Backlash compensation:</i> for compensation of reversal error |
| Data interface | RS-232-C/V.24 300 to 115 200 baud |
| Switching I/O | <ul style="list-style-type: none"> • Input for edge finder (with trigger signal or contact triggering) • Further inputs/outputs over the IOB 49 external input/output unit |
| Accessories | Mounting arms, mounting frame, KT 130 edge finder (for milling) |
| Power connection | AC 100 V to 240 V (-15 % to +10 %), 47 Hz to 63 Hz; 54 W |
| Operating temperature | 0 °C to 45 °C (storage temperature -20 °C to 70 °C) |
| Protection EN 60529 | IP 40, front panel IP 54 |
| Mass | 2.6 kg |

* Please select when ordering

¹⁾ Depends on the signal period of the connected encoder

300S

– Programmable digital readout for up to 4 axes

The 300S digital readout from ACU-RITE is a versatile display unit designed primarily for milling machines, drilling and boring machines and lathes with up to 4 axes. A separate I/O unit provides switching input/outputs for simple tasks in automation.

Execution

The 300S display unit is designed as a sturdy upright unit with splash-proof full-travel keypad for use in the workshop. It supports all operations with straightforward interactive menus on its large, easy-to-read color flat-panel display.

Functions

The 300S digital readout offers all the functions of the 200S.

In addition, the 300S is programmable, which makes it ideal for small-batch production on conventional machine tools: you can store up to 8 programs in the 300S, each with up to 250 working steps. Programs are created by either keying them in step by step or generating them through actual position capture (teach-in programming).

Data interfaces

The 300S features an RS-232-C/V.24 serial interface for measured value transfer to a PC or printer, for input/output of parameters and compensation value lists.

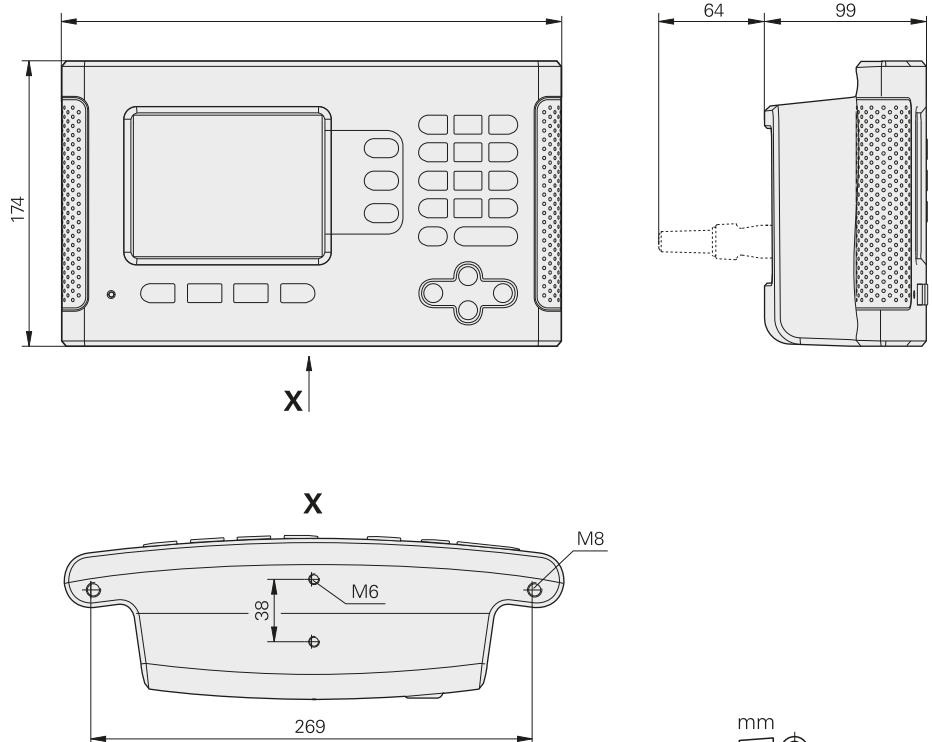

mm
 Tolerancing ISO 8015
 ISO 2768 - m H
 < 6 mm: ±0.2 mm

| | 300S |
|-----------------------------------|---|
| Axes | 4 from A to Z and Z ₀ |
| Encoder inputs | □□ TTL |
| Display step ¹⁾ | Adjustable, max. 7 digits <i>Linear axis:</i> 1 mm to 0.0001 mm <i>Angular axis:</i> 1° bis 0,001° (00° 00' 01") |
| Display | 5.7" color flat-panel display for position values, dialogs and inputs, and soft keys |
| Status display | Tool, reference point, operating function, feed rate, ABS/INC, mm/inch, stopwatch |
| Axis display | Switchable between DRO1 and DRO2 |
| Functions | <ul style="list-style-type: none"> • 10 reference points • 99 tools • REF reference-mark evaluation for distance-coded or single reference marks • Distance-to-go mode • Scaling factor • mm/inch switching • Absolute-incremental display • On-screen help and operating instructions • Graphic positioning aid ("near zero" warning) • Calculator |
| For milling/drilling/boring | <ul style="list-style-type: none"> • Calculation of positions for hole patterns (bolt circles, linear hole patterns) • Tool radius and tool length compensation • Probing functions for reference-point acquisition with KT edge finder: "Edge," "Centerline" and "Circle center" • Oblique line, circular arc • Linear hole patterns, bolt hole circles |
| For turning | <ul style="list-style-type: none"> • Taper calculator • Radius/diameter switching • Freezing the tool position for back-off • Vectoring: X/Y display of the traverse path with inclined top slide • Sum display for Z and Z₀ (axis coupling) |
| Programming | 8 programs with up to 250 steps |
| Error compensation | <ul style="list-style-type: none"> • <i>Axis error:</i> Linear and multipoint over up to 200 points • <i>Backlash compensation:</i> for compensation of reversal error |
| Data interface | RS-232-C/V.24 300 to 115 200 baud |
| Switching I/O | <ul style="list-style-type: none"> • Input for edge finder (with trigger signal or contact triggering) • Further inputs/outputs over the IOB 49 external input/output unit |
| Accessories | Mounting arms, mounting frame, KT 130 edge finder (for milling) |
| Power connection | AC 100 V to 240 V (–15 % to +10 %), 47 Hz to 63 Hz; 30 W |
| Operating temperature | 0 °C to 45 °C (storage temperature –20 °C to 70 °C) |
| Protection EN 60529 | IP 40, front panel IP 54 |
| Mass | 2.6 kg |

¹⁾ Depends on the signal period of the connected encoder

Accessories

– Edge finder

KT 130 edge finder

For any workpiece materials
With spiral cable
ID 283273-S1

The KT 130 is a 3-D triggering edge finder. This means it can also be used for nonconducting materials. The stylus is deflected when it contacts the workpiece, and the edge finder sends a triggering signal over the connecting cable to the 200S or 300S digital readout.

The KT 130 edge finder allows you to set reference points quickly and easily, without leaving marks on the workpiece.

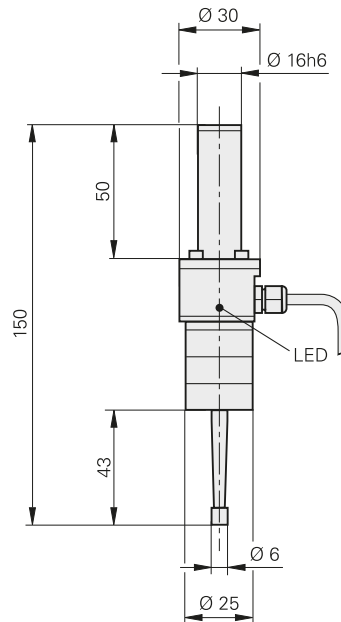

– Mounting components

The **200S** and **300S** digital readouts were conceived as upright units. There are several possible mounting configurations:

- Threaded mounting holes M6 and M8 on the housing floor
- Mounting frame
- Mounting arm and tilt/swivel assembly

Accessories:

Mounting arms (see page 18)

Mounting frame (accessory)

ID 532811-01

For mounting the digital readout in a housing or operating panel

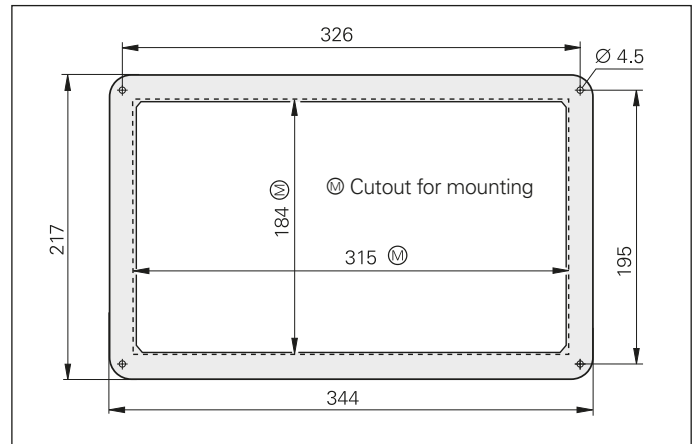

The **VUE** digital readout is fastened either on a mounting arm on the machine, with the aid of a mounting base, or installed in a control panel. The parts required for fastening the display are included in delivery.

They enable you to rotate and tilt the display. The mounting arm, mounting base, and mounting frame are available as accessories:

Accessory:

Mounting arms (see page 18)

Mounting stand

ID 625491-01

Mounting frame

ID 647702-01

For mounting the VUE in a housing or operating panel

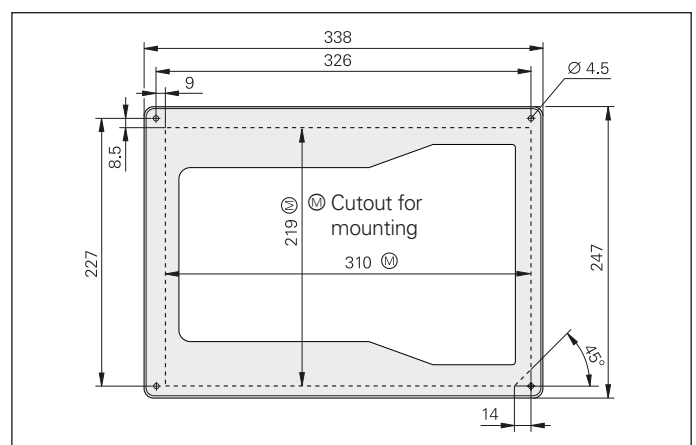
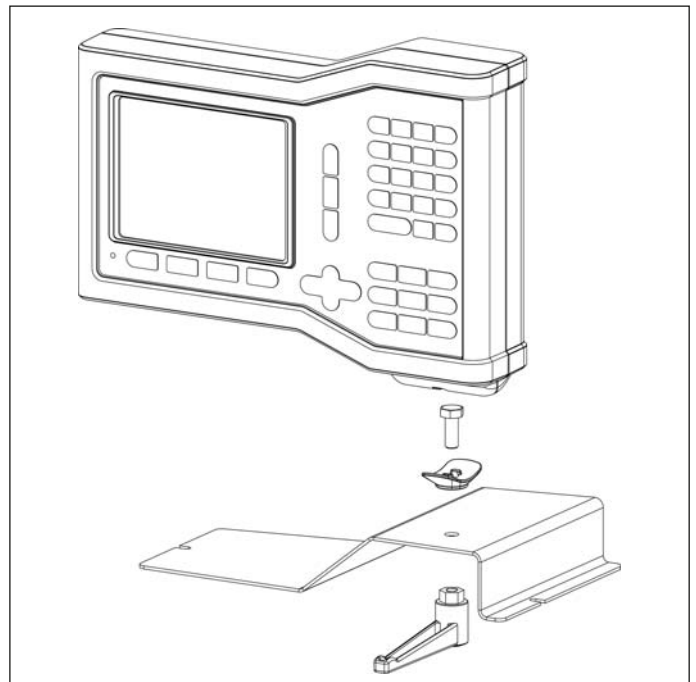

Accessories

– Mounting components

You can use the mounting arm to easily place the display at a conveniently operable position. It can be attached to the machine either with a mounting bracket or directly. The display is attached to the mounting arm by its own tilt/swivel mount.

Mounting arm A

Accessory for VUE, 200S, 300S

Short version: 300 mm

ID 683663-01

Long version: 670 mm

ID 683670-01

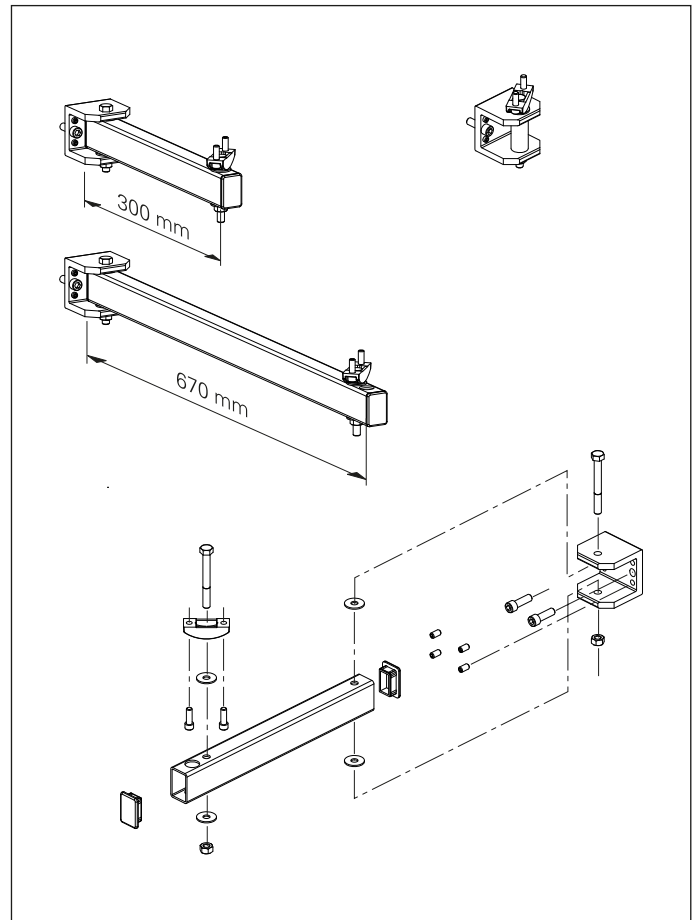

Mounting arm B

Accessory for VUE, 200S, 300S

ID 683665-01

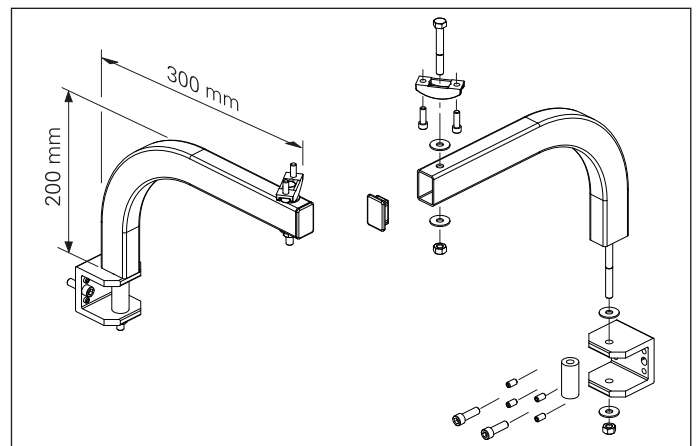

Mounting arm C

Accessory for VUE, 200S, 300S

ID 683671-01

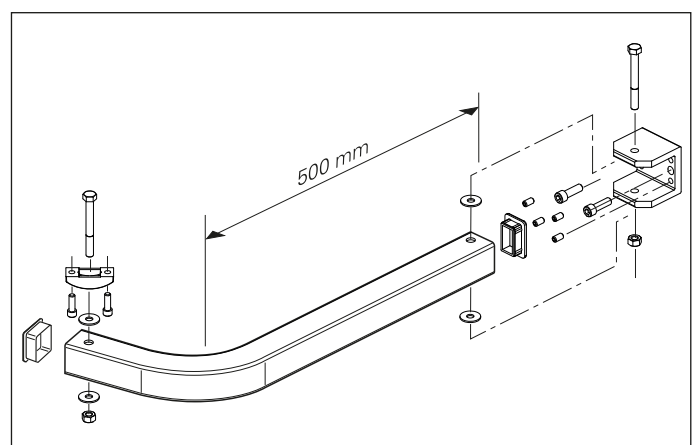

Mounting arm D

Accessory for VUE, 200S, 300S
ID 683668-01

It consists of:
683663-01 and
683673-01 and
683674-01

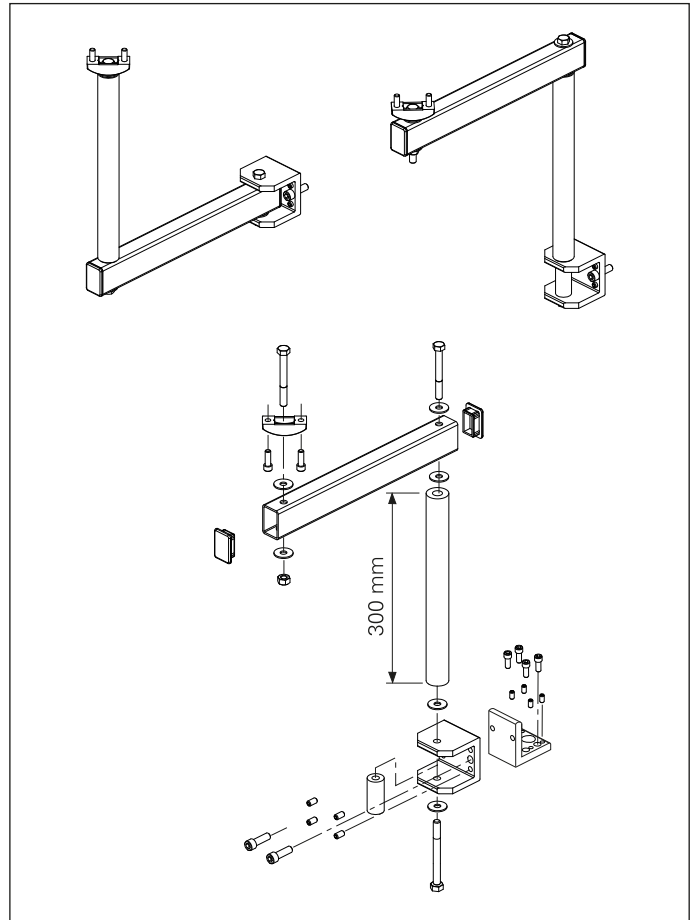

Single parts

a) U section beam with tilt/swivel assembly

Fits mounting arms A and B
ID 683669-01

b) Extension

Fits mounting arms A and B
ID 683673-01

c) Mounting bracket

Fits mounting arms A and B
ID 683674-01

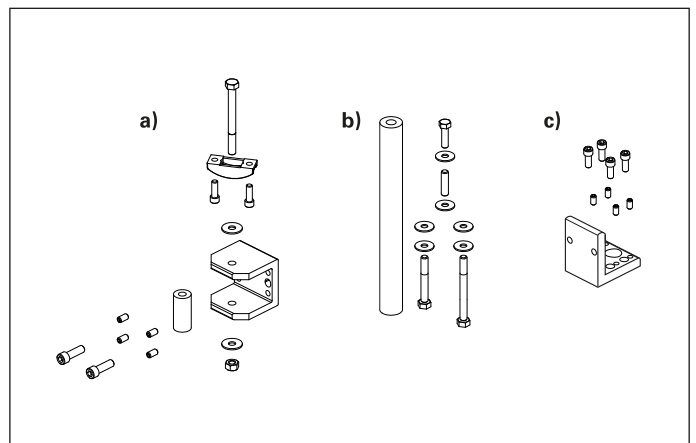

Mounting arm E

Accessory for 200S, 300S
ID 683672-01

The digital readout can be locked in various positions over two ball joints.
Overall height approx. 210 mm

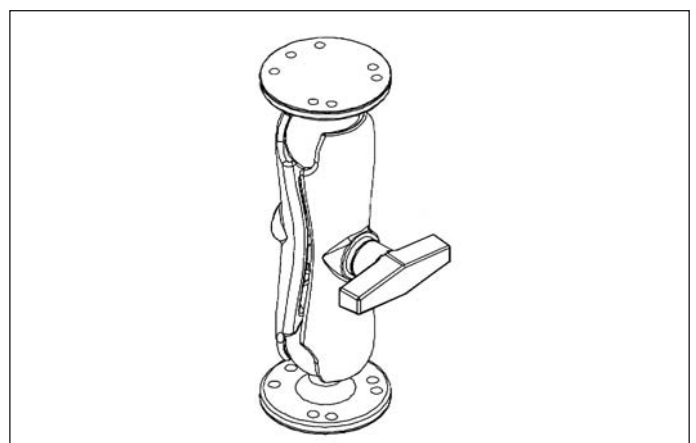

Accessories

– IOB 49 external input/output unit for 200S/300S

The 200S/300S provide application-dependent additional functions that are available when the IOB 49 external input/output unit is connected.

IOB 49 external input/output unit

ID 532900-01

The IOB 49 input/output unit is attached to a standard NS 35 rail (DIN 46227 or EN 50022).

It is connected to the 200S/300S using the touch probe input. LEDs show the power supply, the data transmission and the status of the inputs and outputs.

Accessory:

Connecting cable complete with connector, between IOB 49 and 200S/300S
ID 532899-xx

Distribution cable complete with connectors, for parallel connection of IOB 49 and KT 130 to 200S/300S
ID 532909-01

The additional functions can be configured on the 200S/300S when the IOB 49 is connected.

| | IOB 49 |
|------------------------------|---|
| 4 switching inputs | Zero reset of axes 1 to 3 (for milling applications) Recognition of max. 3 gear ranges (for turning applications) External activation of CSS (for turning applications) |
| 9 switching outputs | 8 relay outputs as switching functions (for milling applications) 1 relay output for readiness |
| 1 analog output | 0 V to 10 V <i>Turning mode:</i> For constant surface speed <i>Milling mode:</i> For controlling the spindle speed |
| Voltage supply | Via 200S/300S |
| Cable length | ≤ 15 m to 200S/300S |
| Storage temperature | 20 °C to 70 °C |
| Operating temperature | 0 °C to 45 °C |

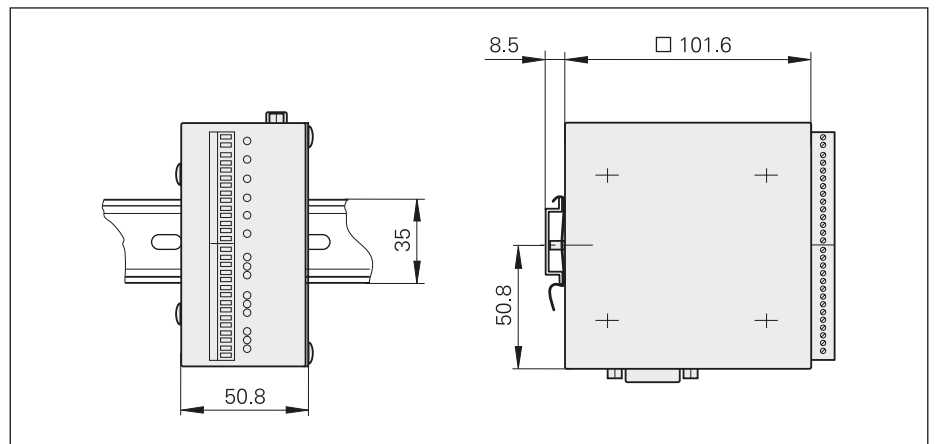

Switching inputs

The switching inputs are active when a High signal (contact or pulse) is present. They are isolated and can be supplied externally or internally.

Signal level of the switching outputs

$$0V \leq U_L \leq 1.5V$$

$$4.5V \leq U_H \leq 26V$$

$$I_L \leq 25 \text{ mA}$$

$$t_{\min} \geq 100 \text{ ms}$$

Zero reset

In the milling mode, each axis can be set to the display value 0 over an external signal.

Detection of gear ranges

In the turning mode, three switching inputs are available for the recognition of gear ranges.

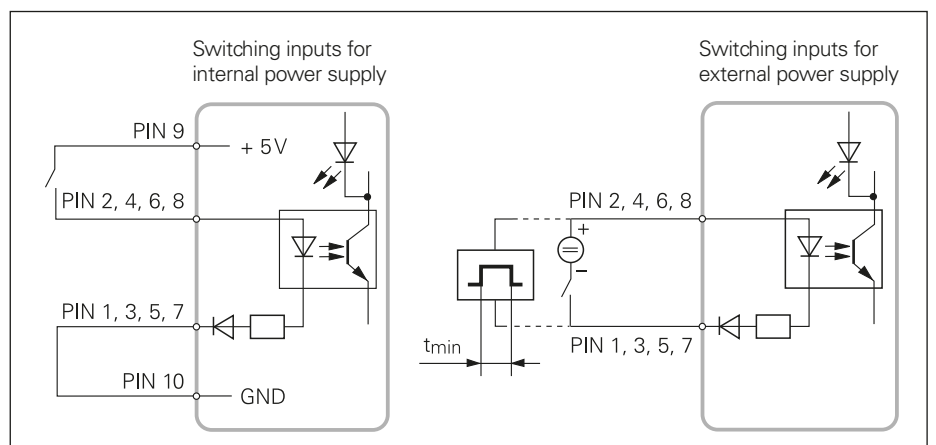

Switching outputs

The IOB 49 features nine floating relay outputs.

Standby

The ready signal output is at LOW level if the 200S/300S cannot operate the IOB (e.g. not switched on, cable disconnected).

Switching functions (for milling applications)

One or more switching ranges or switching points can be defined for an axis. The **switch-off ranges** are located symmetrically around the display value 0. If **switching points** are used, the relay activates when the position display reaches a specific value. The **direction** function switches when the algebraic sign is changed.

You can set whether

- the switching function should apply to the actual value or distance-to-go mode,
- the relay will open or close when the condition is met
- or the relay remains activated as long as the switching condition is met (continuous mode) or for a specified duration (pulsed mode).

Analog output

Constant surface cutting speed CSS

(only in turning applications)

CSS provides spindle speed control as the diameter of the workpiece changes. A speed command signal is sent to the inverter of the spindle motor via the analog interface (DAC 0V to 10V) of the IOB 49. The maximum and minimum permissible spindle speeds can be specified. In addition, a maximum of three operating gears can be taken into account. The 200S/300S recognize the current gear selection by means of the switching inputs of the IOB 49. CSS control can also be started remotely (via an input to the CSS board) with an external switch.

Controlling the spindle speed

(only in milling applications)

With the analog outputs, the speed of the spindle on milling machines can be controlled in an open controlled loop. A spindle speed can be assigned to each tool defined in the tool table. The speed can be manually adapted during machining.

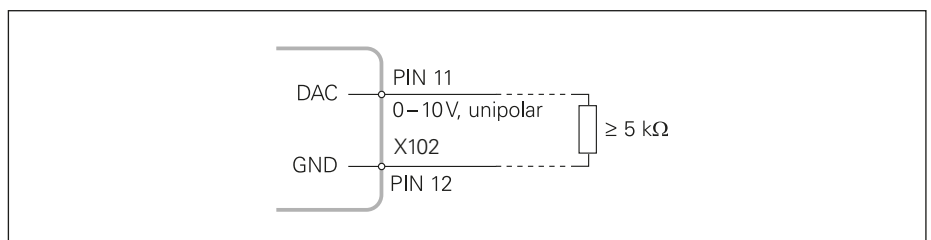
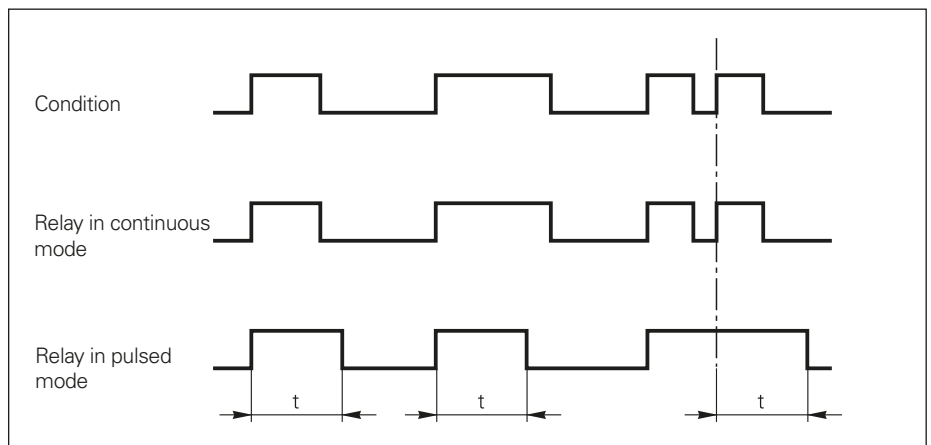
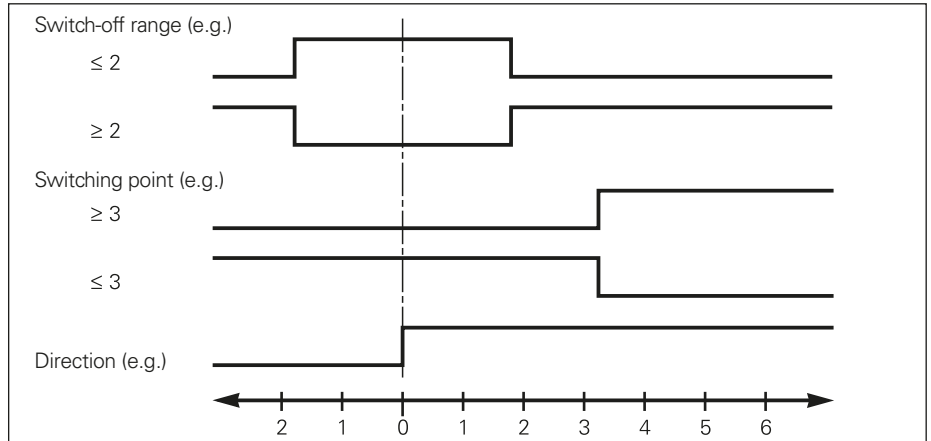
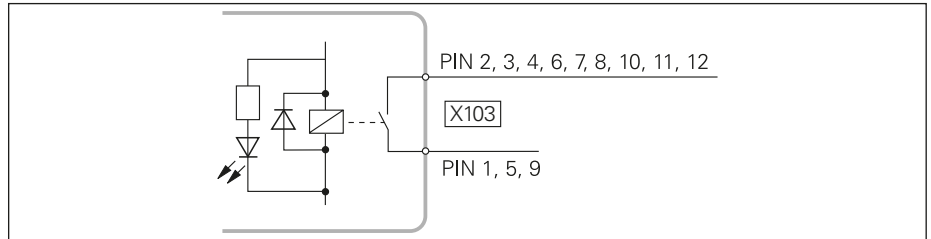



Interfaces

– Digital readouts

Pin layout of encoders \square TTL

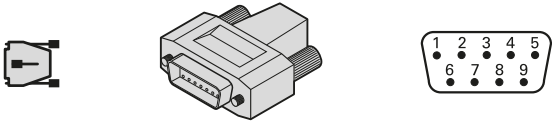
Mating connector:
9-pin D-sub connector (male)



| | Voltage supply | | Incremental signals | | | | | | Others |
|---|----------------|----------|---------------------|---------------------|----------|---------------------|----------|---------------------|----------|
|  | 7 | 6 | 2 | 3 | 4 | 5 | 8 | 9 | 1 |
| \square TTL | U_P | $0V$ | U_{a1} | \overline{U}_{a1} | U_{a2} | \overline{U}_{a2} | U_{a0} | \overline{U}_{a0} | / |

Shield on housing; U_P = Power supply voltage

KT 130 edge finder (only 200S, 300S)

A 15-pin D-sub connection is provided for the KT 130 edge finder.

The trigger signal from the edge finder can also start **data output** (adjustable by parameter).

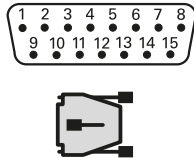

| Pin | Assignment |
|----------------|--------------------|
| 6 | 5 V |
| 1 | 0 V (inner shield) |
| 8 | 0 V |
| 2 | Standby |
| 13 | Trigger signal |
| Remaining pins | Do not assign |
| housing | External shield |

Edge finder with contact triggering (only 200S, 300S)

Edge finders that operate according to the contacting principle can be connected through a 3.5 mm phone jack.

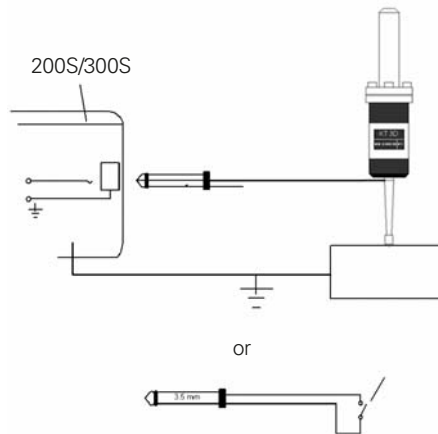

RS-232-C/V.24 (only 200S, 300S)

This serial interface follows the EIA standard RS-232-C and the CCITT standard V.24. It uses a 9-pin D-sub female connection. The data are transferred in ASCII code. The **data format** is adjustable.

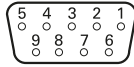

Accessories

Connecting cable, complete with two D-sub connectors (female) 9-pin
ID 366964-xx

Connecting cable, complete with connectors
With D-sub connector (female) 9-pin and 25-pin (male)
ID 368017-xx

| Pin | Assignment |
|-----|-----------------------------|
| 1 | Do not assign |
| 3 | TXD – Transmitted data |
| 2 | RXD – Received data |
| 7 | RTS – Request to send |
| 8 | CTS – Clear to send |
| 6 | DSR – Data set ready |
| 5 | SIGNAL GNDf – Signal ground |
| 4 | DTR – Data Terminal Ready |
| 9 | Do not assign |

| Signal | Signal level 1 = active | Signal level 0 = Not active |
|----------------------|----------------------------|--------------------------------|
| TXD, RXD | -3 V to -15 V | +3 V to +15 V |
| RTS, CTS DSR, DTR | +3 V to +15 V | -3 V to -15 V |

USB (only VUE)

The VUE digital readout has a USB interface function with a type B connector. The USB interface functions as a UART (Universal Asynchronous Receiver Transmitter). A special driver software is required for operation (free download at www.heidenhain.de). The data are transferred in ASCII code.

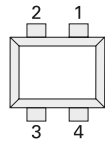

| Pin | Assignment |
|-----|------------|
| 1 | Vcc +5 V |
| 2 | D- Data- |
| 3 | D+ Data+ |
| 4 | GND Mass |

Linear encoders

– For manually operated machine tools

For typical applications on manual machine tools such as milling machines or lathes, **display steps of 10 µm** are sufficient. This is provided by the linear encoder of the SENC 50 and SENC 150 series without interpolation.

Jig boring machines, grinding machines, and measuring and inspection tasks normally require **display steps of 1 µm** and better. The SENC 50 and SENC 150 with integral 5-fold or 10-fold interpolation are suitable for these higher requirements.

For **limited installation space**, for example on the slide of a lathe, the SENC 50 linear encoder may be the best solution.

The SENC 150 linear encoders are used as universal linear encoders under **normal mounting conditions**.



Mounting instructions

SENC 50

This linear encoder with small cross section is fastened at points on a machined surface. With a back-up spar, only two points, one at each end, are sufficient.

For mounting without back-up spar, an intermediate support is required in addition. The encoder is mounted so that the sealing lips are directed downward or away from splash water.

Assembly

When mounting, the scale unit must be aligned at several points along the machine guideway. Stop surfaces or stop pins can also be used to align the scale.

The proper gap between the scale housing and scanning unit is ensured by the shipping brace. You must also ensure that the lateral tolerance is maintained.

Accessories

Back-up spar for SENC 50

ID 680803-xx

The SENC 50 can be mounted on a back-up spar to increase stability.

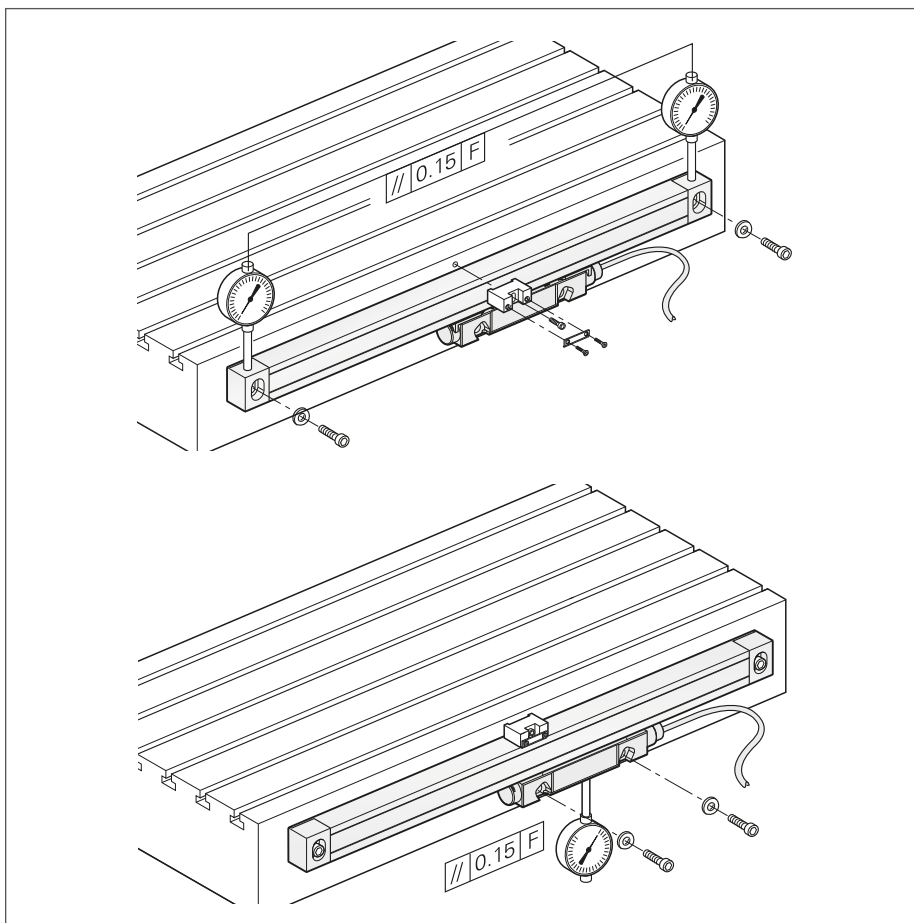

SENC 150

The SENC 150 is fastened at its ends by their mounting blocks to a machined surface. A support bracket is provided for measuring lengths above 625 mm.

If the SENC 150 is mounted with a back-up spar, there is no need for the support bracket. At measuring lengths of 1675 mm or more, the back-up spar is essential. The encoder is mounted so that the sealing lips are directed downward or away from splash water.

Assembly

When the SENC 150 is mounted, the shipping brace already ensures the proper gap between the scale unit and the scanning unit. You need only align the scale unit at several points along the machine guideway.

Accessories

Back-up spar for SENC 150

ID 680116-xx

The SENC 150 can be mounted on a back-up spar to increase stability. At measuring lengths of 1675 mm or more, the back-up spar is essential and is already included in delivery.

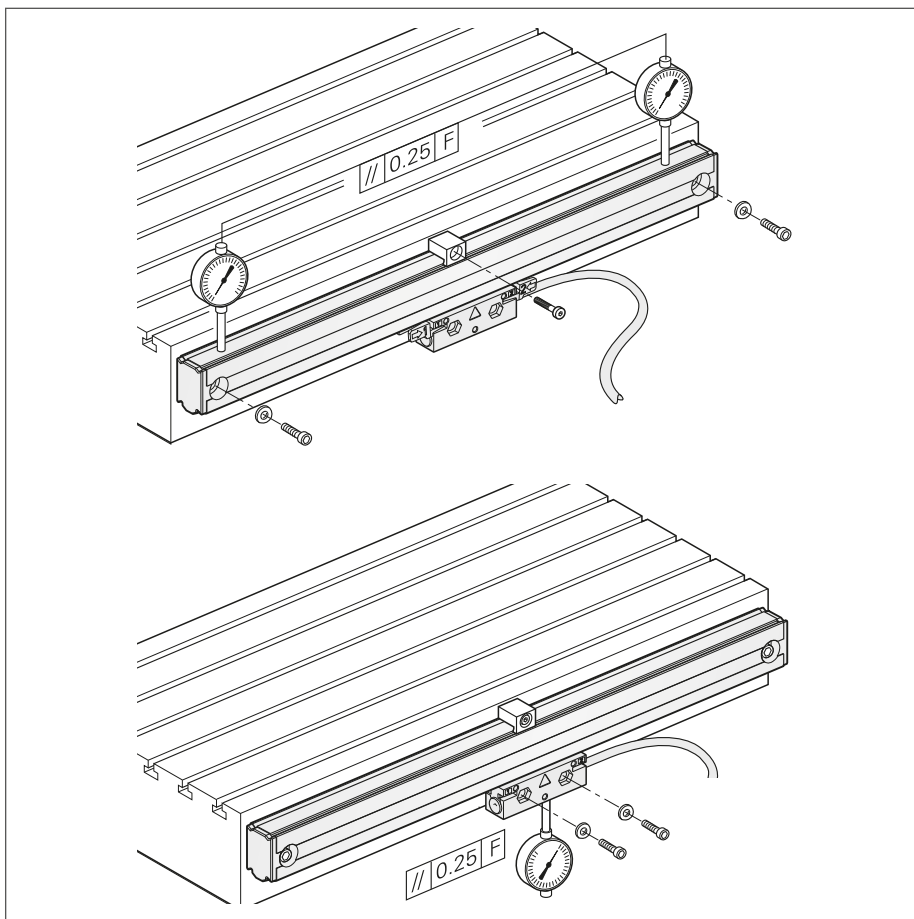

SENC 50

Incremental linear encoder

- Extremely compact dimensions
- Measuring steps 5 μm to 0.5 μm

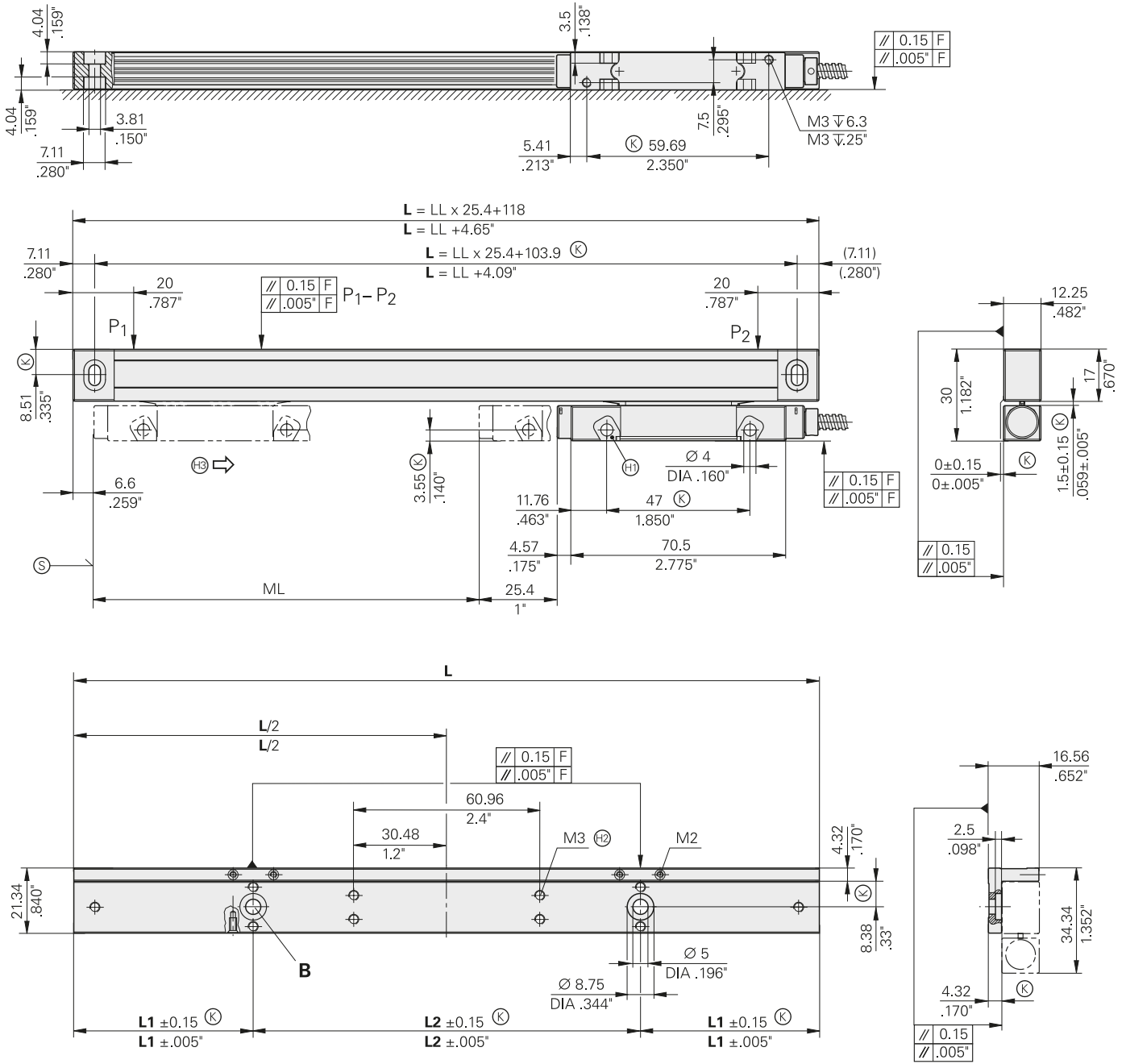

Tolerancing ISO 8015
 Dimensions without
 tolerance ±0.2 mm
 (±.008 inches)

- ML = Measuring length
 P = Gauging points for alignment
 ⊕ = Beginning of measuring length
 ⊙ = Required mating dimensions
 ⊕ = M4 nut usable
 ⊕ = For aligning the back-up spar
 ⊕ = Direction of scanning head motion for output signals in
 accordance with interface description

| ML (mm) | LL (inches) | L | L1 | L2 | Qty. B |
|---------|-------------|--------------|--------------|-----------|--------|
| 50 | 1 | 143.5/5.65" | 20.96/0.825" | 101.6/4" | 2x |
| 75 | 2 | 168.9/6.65" | 20.96/0.825" | 127.0/5" | 2x |
| 100 | 3 | 194.3/7.65" | 33.66/1.325" | 127.0/5" | 2x |
| 125 | 4 | 219.7/8.65" | 46.36/1.825" | 127.0/5" | 2x |
| 150 | 5 | 245.1/9.65" | 59.06/2.325" | 127.0/5" | 2x |
| 175 | 6 | 270.5/10.65" | 71.76/2.825" | 127.0/5" | 2x |
| 200 | 7 | 295.9/11.65" | 84.46/3.325" | 127.0/5" | 2x |
| 225 | 8 | 321.3/12.65" | 97.16/3.825" | 127.0/5" | 2x |
| 250 | 9 | 346.7/13.65" | 46.36/1.825" | 127.0/5" | 3x |
| 275 | 10 | 372.1/14.65" | 59.06/2.325" | 127.0/5" | 3x |
| 300 | 11 | 397.5/15.65" | 71.76/2.825" | 127.0/5" | 3x |
| 325 | 12 | 422.9/16.65" | 84.46/3.325" | 127.0/5" | 3x |
| 350 | 13 | 448.3/17.65" | 97.16/3.825" | 127.0/5" | 3x |
| 375 | 14 | 473.7/18.65" | 46.36/1.825" | 127.0/5" | 4x |
| 425 | 16 | 524.5/20.65" | 71.76/2.825" | 127.0/5" | 4x |
| 475 | 18 | 575.3/22.65" | 33.66/1.325" | 254.0/10" | 3x |
| 525 | 20 | 626.1/24.65" | 59.06/2.325" | 254.0/10" | 3x |



| Specifications | SENC 50 | | |
|---|---|--------------------------|--------------------------|
| Measuring standard | Glass scale with incremental graduation | | |
| Accuracy grade | ±3 µm | | |
| Measuring length ML* | Mounting spar* optional 50 75 100 125 150 175 200 225 250 275 300 325 350 375 425 475 525 | | |
| Incremental signals* | □ TTL | □ TTL x 5 | □ TTL x 10 |
| Grating period Integrated interpolation Signal period | 20 µm Without 20 µm | 20 µm 5-fold 4 µm | 20 µm 10-fold 2 µm |
| Measuring step¹⁾ | 5 µm | 1 µm | 0.5 µm |
| Reference marks | Distance-coded | | |
| Voltage supply Without load | DC 5.1 V ±0.1 V/< 180 mA | DC 5.1 V ±0.1 V/< 220 mA | |
| Electrical connection | Cable in metal armor, with 9-pin D-sub connector; length: 3 m | | |
| Cable length | ≤ 6 m (total length with ACU-RITE cable) | | |
| Traversing speed | ≤ 60 m/min | | |
| Required moving force | ≤ 2.2 N | | |
| Operating conditions | Temperature 0 °C to 50 °C; humidity 25 % to 95 % (non-condensing) | | |
| Conditions for storage | Temperature -20 °C to 70 °C; humidity 20 % to 95 % (non-condensing) | | |
| Protection EN 60529 | IP53 when mounted as per Mounting Instructions | | |
| Mass | 0.5 kg + 0.3 kg/m measuring length | | |

* Please indicate when ordering ¹⁾ After 4-fold evaluation in the subsequent electronics

SENC 150

Incremental linear encoder

- Sturdy design
- Measuring lengths up to 3 m
- Measuring steps 5 μm to 0.5 μm

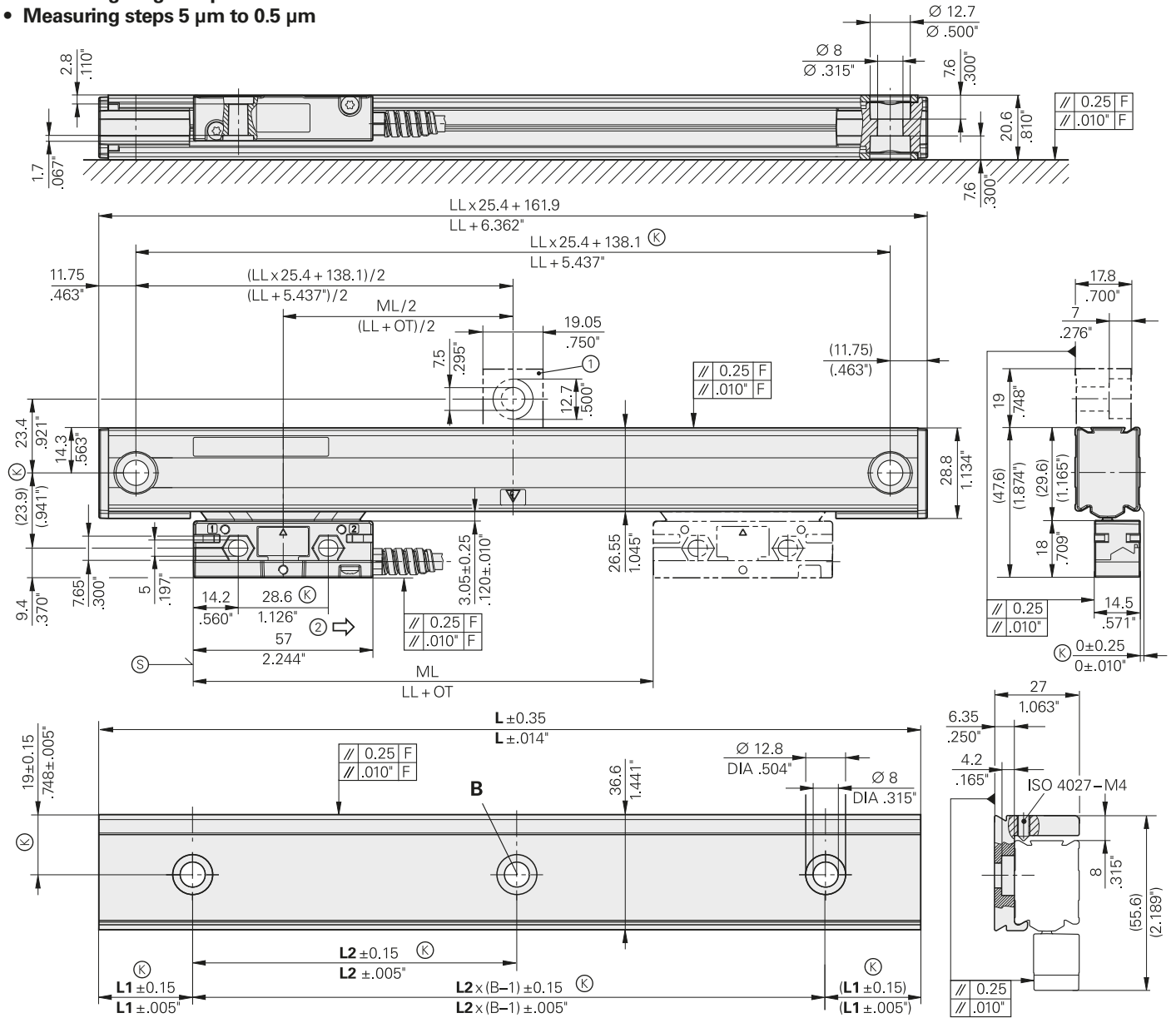

Tolerancing ISO 8015
Dimensions without
tolerance ±0.2 mm
(±.008 inches)

F = Machine guideway

ML = Measuring length in mm

LL = Measuring length in
inches

OT = Overrun 1.75"

⊙ = Beginning of measuring length

Ⓚ = Required mating dimensions

① = ML ≥ 625 mm/24 inches to ≤ 1550 mm/60 inches use mid-point fastening

② = Direction of scanning head motion for output signals in accordance with interface description

| ML | LL | L | L1 | L2 | B |
|-----|-----|-----------------|-----------------|----------------|----|
| 50 | 1" | 185.5 / 7.303" | 29.25 / 1.152" | 127 / 5" | 2x |
| 75 | 2" | 211.5 / 8.327" | 42.25 / 1.663" | 127 / 5" | 2x |
| 100 | 3" | 236.5 / 9.311" | 54.75 / 2.156" | 127 / 5" | 2x |
| 125 | 4" | 261.5 / 10.295" | 67.25 / 2.648" | 127 / 5" | 2x |
| 150 | 5" | 287.5 / 11.319" | 80.25 / 3.159" | 127 / 5" | 2x |
| 175 | 6" | 312.5 / 12.303" | 29.25 / 1.152" | 254 / 10" | 2x |
| 200 | 7" | 338.5 / 13.327" | 42.25 / 1.663" | 254 / 10" | 2x |
| 225 | 8" | 363.5 / 14.311" | 54.75 / 2.156" | 254 / 10" | 2x |
| 275 | 10" | 414.5 / 16.319" | 80.25 / 3.159" | 254 / 10" | 2x |
| 300 | 11" | 439.5 / 17.303" | 92.75 / 3.652" | 254 / 10" | 2x |
| 325 | 12" | 465.5 / 18.327" | 105.75 / 4.163" | 254 / 10" | 2x |
| 350 | 13" | 490.5 / 19.311" | 36.6 / 1.441" | 417.3 / 16.43" | 2x |
| 375 | 14" | 515.5 / 20.295" | 130.75 / 5.148" | 254 / 10" | 2x |
| 400 | 15" | 541.5 / 21.319" | 16.75 / 0.659" | 254 / 10" | 3x |
| 425 | 16" | 566.5 / 22.303" | 29.25 / 1.152" | 254 / 10" | 3x |
| 475 | 18" | 617.5 / 24.311" | 54.75 / 2.156" | 254 / 10" | 3x |
| 525 | 20" | 668.5 / 26.319" | 80.25 / 3.159" | 254 / 10" | 3x |
| 575 | 22" | 719.5 / 28.327" | 105.75 / 4.163" | 254 / 10" | 3x |
| 600 | 23" | 744.5 / 29.311" | 118.25 / 4.656" | 254 / 10" | 3x |
| 625 | 24" | 769.5 / 30.295" | 130.75 / 5.148" | 254 / 10" | 3x |

| ML | LL | L | L1 | L2 | B |
|------|------|-------------------|-----------------|-----------------|-----|
| 675 | 26" | 820.5 / 32.303" | 29.25 / 1.152" | 254 / 10" | 4x |
| 725 | 28" | 871.5 / 34.311" | 54.75 / 2.156" | 254 / 10" | 4x |
| 775 | 30" | 922.5 / 36.319" | 80.25 / 3.159" | 254 / 10" | 4x |
| 875 | 33" | 998.5 / 39.311" | 118.25 / 4.656" | 254 / 10" | 4x |
| 925 | 35" | 1049.5 / 41.319" | 11.25 / 0.443" | 256.8 / 10.109" | 5x |
| 950 | 36" | 1074.5 / 42.303" | 29.25 / 1.152" | 254 / 10" | 5x |
| 1000 | 38" | 1125.5 / 44.311" | 54.75 / 2.156" | 254 / 10" | 5x |
| 1050 | 40" | 1176.5 / 46.319" | 80.25 / 3.159" | 254 / 10" | 5x |
| 1100 | 42" | 1227.5 / 48.327" | 105.75 / 4.163" | 254 / 10" | 5x |
| 1250 | 48" | 1379.5 / 54.311" | 54.75 / 2.156" | 254 / 10" | 6x |
| 1350 | 52" | 1481.5 / 58.327" | 105.75 / 4.163" | 254 / 10" | 6x |
| 1400 | 54" | 1531.5 / 60.295" | 130.75 / 5.148" | 254 / 10" | 6x |
| 1550 | 60" | 1684.5 / 66.319" | 80.25 / 3.159" | 254 / 10" | 7x |
| 1675 | 65" | 1811.5 / 71.319" | 143.75 / 5.659" | 254 / 10" | 7x |
| 1850 | 72" | 1989.5 / 78.327" | 105.75 / 4.163" | 254 / 10" | 8x |
| 2000 | 78" | 2141.5 / 84.311" | 54.75 / 2.156" | 254 / 10" | 9x |
| 2150 | 84" | 2293.5 / 90.295" | 130.75 / 5.148" | 254 / 10" | 9x |
| 2300 | 90" | 2446.5 / 96.319" | 80.25 / 3.159" | 254 / 10" | 10x |
| 2575 | 100" | 2700.5 / 106.319" | 80.25 / 3.159" | 254 / 10" | 11x |
| 2825 | 110" | 2954.5 / 116.319" | 80.25 / 3.159" | 254 / 10" | 12x |
| 3075 | 120" | 3208.5 / 126.319" | 80.25 / 3.159" | 254 / 10" | 13x |



| SENC 150 | | | | |
|---------------------------------------|--|--------------------------|--------------------------|--------------|
| Measuring standard | Glass scale with incremental graduation | | | |
| Accuracy grade | ±5 µm | | | |
| Measuring length ML* | Mounting spar* optional 50 75 100 125 150 175 225 275 300 325 350 375 400 425 475 525 625 675 725 775 825 875 925 950 1000 1050 1100 1250 1350 1400 1550 Back-up spar included in items supplied 1675 1850 2000 2150 2300 2575 2825 3075 | | | |
| Incremental signals* | <table border="1" style="width: 100%; border-collapse: collapse;"> <tr> <td style="width: 33%; text-align: center;">□ □ TTL</td> <td style="width: 33%; text-align: center;">□ □ TTL x 5</td> <td style="width: 33%; text-align: center;">□ □ TTL x 10</td> </tr> </table> | □ □ TTL | □ □ TTL x 5 | □ □ TTL x 10 |
| □ □ TTL | □ □ TTL x 5 | □ □ TTL x 10 | | |
| Grating period | 20 µm | | | |
| Integrated interpolation | Without | | | |
| Signal period | 20 µm | | | |
| Measuring step¹⁾ | <table border="1" style="width: 100%; border-collapse: collapse;"> <tr> <td style="width: 33%;">5 µm</td> <td style="width: 33%;">1 µm</td> <td style="width: 33%;">0.5 µm</td> </tr> </table> | 5 µm | 1 µm | 0.5 µm |
| 5 µm | 1 µm | 0.5 µm | | |
| Reference marks | Distance-coded | | | |
| Voltage supply Without load | <table border="1" style="width: 100%; border-collapse: collapse;"> <tr> <td style="width: 50%;">DC 5.1 V ±0.1 V/< 180 mA</td> <td style="width: 50%;">DC 5.1 V ±0.1 V/< 220 mA</td> </tr> </table> | DC 5.1 V ±0.1 V/< 180 mA | DC 5.1 V ±0.1 V/< 220 mA | |
| DC 5.1 V ±0.1 V/< 180 mA | DC 5.1 V ±0.1 V/< 220 mA | | | |
| Electrical connection | Cable in metal armor, with 9-pin D-sub connector; length: 4 m <i>1250 mm measuring length or more: length 6 m</i> | | | |
| Cable length | ≤ 9 m (total length with ACU-RITE cable) | | | |
| Traversing speed | ≤ 60 m/min | | | |
| Required moving force | ≤ 3.4 N | | | |
| Operating conditions | Temperature 0 °C to 50 °C; humidity 25 % to 95 % (non-condensing) | | | |
| Conditions for storage | Temperature -20 °C to 70 °C; humidity 20 % to 95 % (non-condensing) | | | |
| Protection EN 60529 | IP53 when mounted as per Mounting Instructions | | | |
| Mass | 0.65 kg + 0.7 kg/m measuring length | | | |

* Please indicate when ordering ¹⁾ After 4-fold evaluation in the subsequent electronics

Interfaces

Incremental signals

ACU-RITE encoders with  interface incorporate electronics that digitize sinusoidal scanning signals with or without interpolation.

The **incremental signals** are transmitted as the square-wave pulse trains U_{a1} and U_{a2} , phase-shifted by 90° elec. The **reference mark signal** consists of one or more reference pulses U_{a0} , which are gated with the incremental signals. In addition, the integrated electronics produce their **inverse signals** $\overline{U_{a1}}$ and $\overline{U_{a2}}$ for noise-proof transmission. The illustrated sequence of output signals—with U_{a2} lagging U_{a1} —applies to the direction of motion shown in the dimension drawing.

The distance between two successive edges of the incremental signals U_{a1} and U_{a2} through 1-fold, 2-fold or 4-fold evaluation is one **measuring step**. The subsequent electronics must be designed to detect each edge of the square-wave pulse.

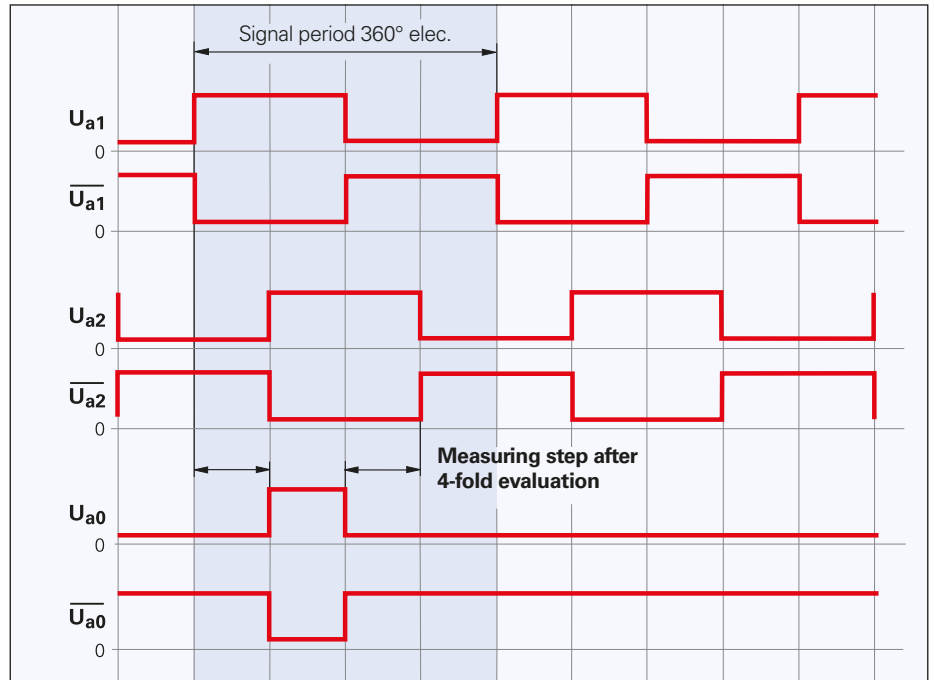

| | |
|------------------------------|--|
| Interface | Square-wave signals  |
| Incremental signals | Two TTL square-wave signals U_{a1} , U_{a2} and their inverted signals $\overline{U_{a1}}$, $\overline{U_{a2}}$ |
| Reference mark signal | One or more square-wave pulses U_{a0} and their inverted pulses $\overline{U_{a0}}$ |
| Pulse width | 90° elec. |
| Signal level | Differential line driver as per EIA standard RS-422 $U_H \geq 2.5 \text{ V}$ at $-I_H = 20 \text{ mA}$ $U_L \leq 0.5 \text{ V}$ at $I_L = 20 \text{ mA}$ |

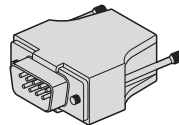
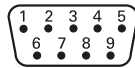

9-pin D-sub connector

On linear encoder or mating connector to digital readout



| | Voltage supply | | Incremental signals | | | | | | |
|--|--------------------|-------|---------------------|--------------------------|---------------|--------------------------|---------------|--------------------------|---|
| PIN | 7 | 6 | 2 | 3 | 4 | 5 | 9 | 8 | 1 |
| Signal | U_P (V_{CC}) | 0V | U_{a1} (A+) | $\overline{U_{a1}}$ (A-) | U_{a2} (B+) | $\overline{U_{a2}}$ (B-) | U_{a0} (R-) | $\overline{U_{a0}}$ (R+) | / |
| SENC 50  | Black | White | Green | Yellow | Pink | Red | Brown | Gray | / |
| SENC 150  | Brown | White | Green | Yellow | Blue | Red | Gray | Pink | / |

Cable shield on housing; U_P = Voltage supply
 Unused pins or wires must not be assigned!
 Color assignment applies only to cable.

Electrical connection

Cables

Extension cables for SENC

ACU-RITE linear encoders feature cables with D-sub connector for direct connection to ACU-RITE digital readouts. The exact length of the cable can be found in the Specifications. If the cable length is

insufficient, extension cables are offered complete with connectors.

Upon request you can also order adapter cables for connection to discontinued ACU-RITE products.

| Extension cable | | Length | In metal armor | Without metal armor |
|---|---|--------|----------------|---------------------|
| Complete with D-sub connectors (female and male) |  | 1.5 m | 683276-05 | 683277-05 |
| | | 3.0 m | 683276-10 | 683277-10 |
| | | 4.5 m | 683276-15 | 683277-15 |
| | | 6.0 m | 683276-20 | 683277-20 |
| | | 7.5 m | 683276-25 | 683277-25 |

General electrical information

Transmission of measuring signals—electrical noise immunity

Noise voltages arise mainly through capacitive or inductive transfer. Electrical noise can be introduced into the system over signal lines and input or output terminals.

Possible sources of noise include:

- Strong magnetic fields from transformers, brakes and electric motors
- Relays, contactors and solenoid valves
- High-frequency equipment, pulse devices, and stray magnetic fields from switch-mode power supplies
- AC power lines and supply lines to the above devices

Protection against electrical noise

The following measures must be taken to ensure disturbance-free operation:

- Use only original ACU-RITE cables. Consider the voltage drop on supply lines.
- Use connecting elements (such as connectors or terminal boxes) with metal housings. Only the signals and power supply of the connected encoder may be routed through these elements.

Applications in which additional signals are sent through the connecting element require specific measures regarding electrical safety and EMC.

- Connect the housings of the encoder, connecting elements and subsequent electronics through the shield of the cable. Connect the shield over a large area and in all directions (360°). For encoders with more than one electrical connection, refer to the documentation for the respective product.
- For cables with multiple shields, the inner shields must be routed separately from the outer shield. Connect the inner shield to 0 V of the subsequent electronics. Do not connect the inner shields with the outer shield, neither in the encoder nor in the cable.
- Connect the shield to protective ground as per the mounting instructions.
- Prevent contact of the shield (e.g. connector housing) with other metal surfaces. Pay attention to this when installing cables.
- Do not install signal cables in the direct vicinity of interference sources (inductive consumers such as contactors, motors, frequency inverters, solenoids, etc.).

– Sufficient decoupling from interference-signal-conducting cables can usually be achieved by an air clearance of 100 mm or, when cables are in metal ducts, by a grounded partition.

– A minimum spacing of 200 mm to inductors in switch-mode power supplies is required.

- If compensating currents are to be expected within the overall system, a separate equipotential bonding conductor must be provided. The shielding does not have the function of an equipotential bonding conductor.
- Provide power only from PELV systems (**EN 50 178**) to the position encoders. Provide high-frequency grounding with low impedance (**EN 60204-1 Chap. EMV**).

HEIDENHAIN

DR. JOHANNES HEIDENHAIN GmbH

Dr.-Johannes-Heidenhain-Straße 5

83301 Traunreut, Germany

☎ +49 8669 31-0

FAX +49 8669 32-5061

E-mail: info@heidenhain.de

www.heidenhain.de

Vollständige und weitere Adressen siehe www.heidenhain.de
For complete and further addresses see www.heidenhain.de

| | | | | | |
|-----------|--|-----------|--|-----------|---|
| DE | HEIDENHAIN Vertrieb Deutschland 83301 Traunreut, Deutschland ☎ 08669 31-3132 FAX 08669 32-3132 E-Mail: hd@heidenhain.de | ES | FARRESA ELECTRONICA S.A. 08028 Barcelona, Spain www.farresa.es | PL | APS 02-384 Warszawa, Poland www.heidenhain.pl |
| | HEIDENHAIN Technisches Büro Nord 12681 Berlin, Deutschland ☎ 030 54705-240 | FI | HEIDENHAIN Scandinavia AB 01740 Vantaa, Finland www.heidenhain.fi | PT | FARRESA ELECTRÓNICA, LDA. 4470 - 177 Maia, Portugal www.farresa.pt |
| | HEIDENHAIN Technisches Büro Mitte 07751 Jena, Deutschland ☎ 03641 4728-250 | FR | HEIDENHAIN FRANCE sarl 92310 Sèvres, France www.heidenhain.fr | RO | HEIDENHAIN Reprezentanță Romania Braşov, 500407, Romania www.heidenhain.ro |
| | HEIDENHAIN Technisches Büro West 44379 Dortmund, Deutschland ☎ 0231 618083-0 | GB | HEIDENHAIN (G.B.) Limited Burgess Hill RH15 9RD, United Kingdom www.heidenhain.co.uk | RS | Serbia → BG |
| | HEIDENHAIN Technisches Büro Südwest 70771 Leinfelden-Echterdingen, Deutschland ☎ 0711 993395-0 | GR | MB Milionis Vassilis 17341 Athens, Greece www.heidenhain.gr | RU | OOO HEIDENHAIN 115172 Moscow, Russia www.heidenhain.ru |
| | HEIDENHAIN Technisches Büro Südost 83301 Traunreut, Deutschland ☎ 08669 31-1345 | HK | HEIDENHAIN LTD Kowloon, Hong Kong E-mail: sales@heidenhain.com.hk | SE | HEIDENHAIN Scandinavia AB 12739 Skärholmen, Sweden www.heidenhain.se |
| | | HR | Croatia → SL | SG | HEIDENHAIN PACIFIC PTE LTD. Singapore 408593 www.heidenhain.com.sg |
| AR | NAKASE SRL. B1653AOX Villa Ballester, Argentina www.heidenhain.com.ar | HU | HEIDENHAIN Kereskedelmi Képviselet 1239 Budapest, Hungary www.heidenhain.hu | SK | KOPRETINA TN s.r.o. 91101 Trenčín, Slovakia www.kopretina.sk |
| AT | HEIDENHAIN Techn. Büro Österreich 83301 Traunreut, Germany www.heidenhain.de | ID | PT Servitama Era Toolsindo Jakarta 13930, Indonesia E-mail: ptset@group.gts.co.id | SL | NAVO d.o.o. 2000 Maribor, Slovenia www.heidenhain.si |
| AU | FCR Motion Technology Pty. Ltd Laverton North 3026, Australia E-mail: vicsales@fcrmotion.com | IL | NEUMO VARGUS MARKETING LTD. Tel Aviv 61570, Israel E-mail: neumo@neumo-vargus.co.il | TH | HEIDENHAIN (THAILAND) LTD Bangkok 10250, Thailand www.heidenhain.co.th |
| BE | HEIDENHAIN NV/SA 1760 Roosdaal, Belgium www.heidenhain.be | IN | HEIDENHAIN Optics & Electronics India Private Limited Chetpet, Chennai 600 031, India www.heidenhain.in | TR | T&M Mühendislik San. ve Tic. LTD. ŞTİ. 34775 Y. Dudullu – Ümraniye-Istanbul, Turkey www.heidenhain.com.tr |
| BG | ESD Bulgaria Ltd. Sofia 1172, Bulgaria www.esd.bg | IT | HEIDENHAIN ITALIANA S.r.l. 20128 Milano, Italy www.heidenhain.it | TW | HEIDENHAIN Co., Ltd. Taichung 40768, Taiwan R.O.C. www.heidenhain.com.tw |
| BR | DIADUR Indústria e Comércio Ltda. 04763-070 – São Paulo – SP, Brazil www.heidenhain.com.br | JP | HEIDENHAIN K.K. Tokyo 102-0083, Japan www.heidenhain.co.jp | UA | Gertner Service GmbH Büro Kiev 01133 Kiev, Ukraine www.heidenhain.ua |
| BY | GERTNER Service GmbH 220026 Minsk, Belarus www.heidenhain.by | KR | HEIDENHAIN Korea LTD. Gasan-Dong, Seoul, Korea 153-782 www.heidenhain.co.kr | US | HEIDENHAIN CORPORATION Schaumburg, IL 60173-5337, USA www.heidenhain.com |
| CA | HEIDENHAIN CORPORATION Mississauga, Ontario L5T 2N2, Canada www.heidenhain.com | MX | HEIDENHAIN CORPORATION MEXICO 20290 Aguascalientes, AGS., Mexico E-mail: info@heidenhain.com | VE | Maquinaria Diekmann S.A. Caracas, 1040-A, Venezuela E-mail: purchase@diekmann.com.ve |
| CH | HEIDENHAIN (SCHWEIZ) AG 8603 Schwerzenbach, Switzerland www.heidenhain.ch | MY | ISOSERVE SDN. BHD. 43200 Balakong, Selangor E-mail: sales@isoserve.com.my | VN | AMS Co. Ltd HCM City, Vietnam E-mail: davidgoh@amsvn.com |
| CN | DR. JOHANNES HEIDENHAIN (CHINA) Co., Ltd. Beijing 101312, China www.heidenhain.com.cn | NL | HEIDENHAIN NEDERLAND B.V. 6716 BM Ede, Netherlands www.heidenhain.nl | ZA | MAFEMA SALES SERVICES C.C. Midrand 1685, South Africa www.heidenhain.co.za |
| CZ | HEIDENHAIN s.r.o. 102 00 Praha 10, Czech Republic www.heidenhain.cz | NO | HEIDENHAIN Scandinavia AB 7300 Orkanger, Norway www.heidenhain.no | | |
| DK | TPTEKNIK A/S 2670 Greve, Denmark www.tp-gruppen.dk | PH | Machinebanks Corporation Quezon City, Philippines 1113 E-mail: info@machinebanks.com | | |

